

2002

# Synthesis and gas phase thermochemistry of germanium-containing compounds

Nathan Robert Classen  
*Iowa State University*

Follow this and additional works at: <https://lib.dr.iastate.edu/rtd>

 Part of the [Organic Chemistry Commons](#)

## Recommended Citation

Classen, Nathan Robert, "Synthesis and gas phase thermochemistry of germanium-containing compounds " (2002). *Retrospective Theses and Dissertations*. 507.  
<https://lib.dr.iastate.edu/rtd/507>

This Dissertation is brought to you for free and open access by the Iowa State University Capstones, Theses and Dissertations at Iowa State University Digital Repository. It has been accepted for inclusion in Retrospective Theses and Dissertations by an authorized administrator of Iowa State University Digital Repository. For more information, please contact [digirep@iastate.edu](mailto:digirep@iastate.edu).

## **INFORMATION TO USERS**

**This manuscript has been reproduced from the microfilm master. UMI films the text directly from the original or copy submitted. Thus, some thesis and dissertation copies are in typewriter face, while others may be from any type of computer printer.**

**The quality of this reproduction is dependent upon the quality of the copy submitted. Broken or indistinct print, colored or poor quality illustrations and photographs, print bleedthrough, substandard margins, and improper alignment can adversely affect reproduction.**

**In the unlikely event that the author did not send UMI a complete manuscript and there are missing pages, these will be noted. Also, if unauthorized copyright material had to be removed, a note will indicate the deletion.**

**Oversize materials (e.g., maps, drawings, charts) are reproduced by sectioning the original, beginning at the upper left-hand corner and continuing from left to right in equal sections with small overlaps.**

**ProQuest Information and Learning  
300 North Zeeb Road, Ann Arbor, Mi 48106-1346 USA  
800-521-0600**

**UMI<sup>®</sup>**



**Synthesis and gas phase thermochemistry of germanium-  
containing compounds**

**by**

**Nathan Robert Classen**

**A dissertation submitted to the graduate faculty  
in partial fulfillment of the requirements for the degree of  
DOCTOR OF PHILOSOPHY**

**Major: Organic Chemistry**

**Program of Study Committee:  
Thomas J. Barton, Major Professor  
Valerie V. Sheares Ashby  
Vikram L. Dalal  
Richard C. Larock  
Victor Shang-Yi Lin**

**Iowa State University  
Ames, Iowa State University**

**2002**

UMI Number: 3073442

**UMI<sup>®</sup>**

---

UMI Microform 3073442

Copyright 2003 by ProQuest Information and Learning Company.  
All rights reserved. This microform edition is protected against  
unauthorized copying under Title 17, United States Code.

---

ProQuest Information and Learning Company  
300 North Zeeb Road  
P.O. Box 1346  
Ann Arbor, MI 48106-1346

**Graduate College  
Iowa State University**

**This is to certify that the doctoral dissertation of**

**Nathan Robert Classen**

**has met the dissertation requirements of Iowa State University**

Signature was redacted for privacy.

**Major Professor**

Signature was redacted for privacy.

**For the Major Program**

**TABLE OF CONTENTS**

<b>LIST OF SCHEMES</b>	vi
<b>LIST OF FIGURES</b>	xiii
<b>LIST OF TABLES</b>	xv
<b>ABSTRACT</b>	xviii
<b>GENERAL INTRODUCTION</b>	1
<b>CHAPTER 1. TOWARDS THE SYNTHESIS AND STUDY OF METHYLENE GERMACYCLOBUTANES</b>	4
Abstract	4
Introduction	5
Results and Discussion	19
Conclusion	30
Experimental Section	31
References	49
Appendix. Mass spectra of methylenegermacyclobutanes	51
<b>CHAPTER 2. EXAMINATION OF THE THERMAL BEHAVIOR OF VARIOUS ORGANOGERMANIUM COMPOUNDS</b>	55
Introduction and Literature Survey	55
Results and Discussion	79

Conclusion	117
Experimental Section	118
References	149
Appendix. Deuterium incorporation data	153
<b>CHAPTER 3. EXAMINATION OF THE THERMAL BEHAVIOR OF DIALLYLDIMETHYLGERMANE</b>	<b>160</b>
Abstract	160
Introduction	160
Results and Discussion	169
Conclusion	175
Experimental Section	177
References	182
<b>CHAPTER 4. STUDY OF A NOVEL METHYLENESILACYCLOBUTENE</b>	<b>183</b>
Abstract	183
Introduction	183
Results and Discussion	191
Conclusion	205
Experimental Section	206
References	216
<b>GENERAL CONCLUSIONS</b>	<b>217</b>



**ACKNOWLEDGMENTS**

**LIST OF SCHEMES****CHAPTER 1. TOWARDS THE SYNTHESIS AND STUDY OF METHYLENE  
GERMACYCLOBUTANES**

Scheme 1.	Examples of olefin to carbene isomerization.	6
Scheme 2.	Synthesis of methylenesilacyclobutane <b>1</b> .	7
Scheme 3.	Pyrolysis and proposed mechanism of methylenesila- cyclobutane <b>1</b> .	8
Scheme 4.	Pyrolysis of <i>o</i> -(dimethylsilyl)phenylacetylene <b>20</b> .	8
Scheme 5.	Isomerization of methylenebenzosilacyclobutane <b>22</b> .	9
Scheme 6.	Synthesis of dimethylenedisilacyclobutane <b>28</b> .	9
Scheme 7.	Pyrolysis of dimethylenedisilacyclobutane <b>28</b> .	10
Scheme 8.	Calculated ring strains.	11
Scheme 9.	Thermal decomposition and Arrhenius parameters for related systems.	12
Scheme 10.	Synthesis of methylenesilacyclobutane <b>1</b> .	13
Scheme 11.	SFR Pyrolysis of methylenesilacyclobutane <b>1</b> .	13
Scheme 12.	Deuterium scrambling in the pyrolysis of methylene- silacyclobutane <b>1D</b> .	14
Scheme 13.	Pyrolysis of germacyclobutane <b>37</b> .	15
Scheme 14.	Trapping studies of germacyclobutane <b>37</b> with 1,3-butadiene.	16
Scheme 15.	Decomposition of germacyclobutane <b>37</b> .	17
Scheme 16.	Proposed mechanism of decomposition of germacyclobutane <b>37</b> .	18
Scheme 17.	Attempted synthesis of methylenegermacyclobutane <b>2</b> .	19

Scheme 18.	Synthesis of dimethylenedigermacyclobutane <b>50</b> .	20
Scheme 19.	Activated magnesium coupling of dibromobutene <b>36</b> and dialkyldichlorogermanes.	21
Scheme 20.	Synthesis of diethyldichlorogermane ( <b>51</b> ) and dibutyl-dichlorogermane ( <b>52</b> ).	22
Scheme 21.	Decomposition: pathways of methylenegermacyclobutane <b>54</b> .	24
Scheme 22.	Pyrolysis of methylenegermacyclobutane <b>54</b> .	24
Scheme 23.	Synthesis of germacyclopent-3-ene <b>57</b> .	25
Scheme 24.	Synthesis of dibromobutene <b>69</b> .	26
Scheme 25.	Synthesis of germacyclopent-2-enes <b>71</b> and <b>58</b> .	26
Scheme 26.	Proposed mechanism of isomerization of germacyclopent-3-ene <b>57</b> to germacyclopent-2-ene <b>58</b> .	28
Scheme 27.	Decomposition of dibutylgermylene.	29
Scheme 28.	Synthesis of methylenegermacyclobutane <b>72</b> .	30

## **CHAPTER 2. THERMAL BEHAVIOR OF VARIOUS ORGANOGERMANIUM COMPOUNDS**

Scheme 1.	Overall decomposition of germane ( <b>1</b> ).	56
Scheme 2.	Mechanism of the thermal decomposition of germane ( <b>1</b> ).	58
Scheme 3.	Primary modes of methylgermane ( <b>3</b> ) decomposition.	60
Scheme 4.	Possible secondary processes of the decomposition of <b>3</b> .	61
Scheme 5.	Route of HD production through methylgermylene isomerization.	62
Scheme 6.	Products of trimethylgermane ( <b>5</b> ) decomposition.	64

Scheme 7.	Proposed mechanism of trimethylgermane ( <b>5</b> ) thermal decomposition.	65
Scheme 8.	Trapping products of the pyrolysis of trimethylgermane ( <b>5</b> ) in the presence of 1,3-butadiene.	65
Scheme 9.	Proposed mechanism of trimethylgermane-d ( <b>5D</b> ) thermal decomposition.	66
Scheme 10.	Mechanism of decomposition of tetramethylgermane ( <b>11</b> ) (above 710 °C).	68
Scheme 11.	Products of CO <sub>2</sub> induced decomposition of <b>12</b> and <b>13</b> .	70
Scheme 12.	Proposed mechanism of the thermolysis of triethylgermane ( <b>14</b> ).	72
Scheme 13.	Mechanism of diethylgermane ( <b>13</b> ) formation in the decomposition of ( <b>14</b> ).	73
Scheme 14.	Proposed mechanism of tetraethylgermane ( <b>17</b> ) decomposition.	75
Scheme 15.	Gaseous products in the MOCVD of tetraethylgermane ( <b>17</b> ).	76
Scheme 16.	Trapping products in the thermal decomposition of 1,1-dibutyl-1-germacyclopent-3-ene ( <b>21</b> ).	79
Scheme 17.	Static pyrolysis of pentaethylchlorodigermene.	80
Scheme 18.	Pyrolysis and mechanism of hexylsilane-d <sub>3</sub> ( <b>29D</b> ).	81
Scheme 19.	Proposed decomposition of dibutylgermylene ( <b>20</b> ).	82
Scheme 20.	Decomposition of methyl(trimethylsilyl)germylene ( <b>33</b> ) and C-H insertion.	82
Scheme 21.	Intramolecular C-H insertion of germylene <b>35</b> .	83
Scheme 22.	Thermal routes to germylenes.	84
Scheme 23.	Synthesis of dihexylgermacyclopentenes <b>40</b> and <b>41</b> .	85
Scheme 24.	Synthesis of dihexyl(trimethylsilyl)germane ( <b>45</b> ).	85

Scheme 25.	Synthesis of dihexylgermanes <b>49</b> and <b>49D</b> and hexylgermanes <b>48</b> and <b>48D</b> .	86
Scheme 26.	Synthesis of trihexylgermanes <b>51</b> and <b>51D</b> .	87
Scheme 27.	FVP of hexylgermane ( <b>48</b> ) and hexylgermane ( <b>48D</b> ).	88
Scheme 28.	Proposed mechanism for the decomposition of dihexylgermylene ( <b>52</b> ) through consecutive C-H insertion and elimination.	90
Scheme 29.	Kinetics of product distribution of the pyrolysis of <b>40</b> , <b>41</b> , and <b>45</b> .	91
Scheme 30.	Kinetics of the formation of 2,3-dimethyl-1,3-butadiene and ethylene in the thermal decomposition of <b>72</b> .	92
Scheme 31.	Trapping experiments with dihexyl(trimethylsilyl)germane ( <b>45</b> ) and isoprene.	93
Scheme 32.	Deuterium incorporation observed in the products of hexylgermane-d <sub>3</sub> ( <b>48D</b> ) decomposition.	96
Scheme 33.	Proposed mechanisms for deuterium incorporation in the products of hexylgermane-d <sub>3</sub> ( <b>48D</b> ) thermal decomposition.	97
Scheme 34.	Deuterium incorporation of the products of dihexylgermane-d <sub>2</sub> ( <b>49D</b> ) decomposition.	99
Scheme 35.	Proposed mechanisms of deuterium incorporation in the thermal decomposition of dihexylgermane-d <sub>2</sub> ( <b>49D</b> ).	100
Scheme 36.	Deuterium incorporation pathways in the decomposition of trihexylgermane-d ( <b>51D</b> ).	104
Scheme 37.	Deuterium incorporation of the products of trihexylgermane-d ( <b>51D</b> ) decomposition.	105
Scheme 38.	Proposed mechanism for the thermal decomposition of tetrabutylgermane ( <b>19</b> ).	107
Scheme 39.	Proposed model for atomic layer epitaxy of Ge from Et <sub>2</sub> GeH <sub>2</sub> .	111
Scheme 40.	Design of of the low-temperature thermal germylene precursor, ethylmethyl(trimethylsilyl)germane ( <b>64</b> ).	113

Scheme 41.	Synthesis of the low temperature thermal germylene precursor, ethylmethyl(trimethylsilyl)germane ( <b>64</b> ).	114
Scheme 42.	Flow pyrolysis of ethylmethyl(trimethylsilyl)germane ( <b>64</b> ).	115
Scheme 43.	Separate synthesis of the pyrolysis products of <b>64</b> .	116

### CHAPTER 3. EXAMINATION OF THE THERMAL BEHAVIOR OF DIALYLDIMETHYLGERMANE.

Scheme 1.	Pyrolysis of diallyldimethylsilane ( <b>2</b> ).	160
Scheme 2.	Retro-ene elimination of propene in the pyrolysis of allyltrimethylsilane ( <b>5</b> ).	161
Scheme 3.	Intramolecular processes in the proposed mechanism of the pyrolysis of diallyldimethylsilane ( <b>2</b> ).	164
Scheme 4.	Radical processes in the proposed mechanism of the pyrolysis of diallyldimethylsilane ( <b>2</b> ).	165
Scheme 5.	Proposed mechanism of ethylene and propene formation during diallyldiethylgermane ( <b>16</b> ) decomposition.	167
Scheme 6.	Proposed mechanism of 1,5-hexadiene formation during diallyldiethylgermane ( <b>16</b> ) decomposition.	167
Scheme 7.	Pyrolysis of allyltrimethylgermane ( <b>18</b> ) in the presence of 2,3-dimethyl-1,3-butadiene.	168
Scheme 8.	Proposed mechanism of the pyrolysis of allyltrimethylgermane ( <b>18</b> ).	169
Scheme 9.	Possible pyrolytic reaction pathways of diallyldimethylgermane ( <b>1</b> ).	170
Scheme 10.	Pyrolysis of diallyldimethylgermane ( <b>1</b> ) in the presence of 2,3-dimethyl-1,3-butadiene.	170
Scheme 11.	Pyrolysis of diallyldimethylgermane ( <b>1</b> ) in the presence of <i>n</i> -butyl chloride.	171

Scheme 12.	Proposed mechanism for the formation of propene, 1,5-hexadiene, and allyltrimethylgermane ( <b>18</b> ) during the pyrolysis of diallyldimethylgermane ( <b>1</b> ).	173
Scheme 13.	SFR pyrolysis of diallyldimethylgermane ( <b>1</b> ) in the presence of 2,3-dimethyl-1,3-butadiene.	173
Scheme 14.	Mechanism of diallyldimethylgermane ( <b>1</b> ) decomposition.	176

#### CHAPTER 4. STUDY OF A NOVEL METHYLENESILACYCLOBUTANE

Scheme 1.	1,2-Silyl shift of 1,1-dimethyl-2-methylenesilacyclobutane ( <b>1</b> ).	184
Scheme 2.	Possible thermal rearrangement of methylenesilacyclobutene <b>4</b> .	185
Scheme 3.	Possible siladiene formation from methylenesilacyclobutene <b>4</b> .	185
Scheme 4.	Synthesis of methylenesilacyclobutenes <b>4</b> and <b>8</b> .	186
Scheme 5.	Chemical reactivity of methylenesilacyclobutene <b>4</b> .	187
Scheme 6.	Parent silacyclobutene thermal rearrangement.	187
Scheme 7.	Photolysis of phenylsilacyclobutene <b>20</b> .	188
Scheme 8.	Mechanism of silacyclobutene photolysis.	189
Scheme 9.	Reaction of silacyclobutene with methanol in the dark.	190
Scheme 10.	Mechanism of the reaction of <b>12</b> with methanol in the dark.	190
Scheme 11.	Reaction of methylenesilacyclobutene <b>4</b> with alcohols.	192
Scheme 12.	Mechanism of the ring opening of methylenesilacyclobutene <b>4</b> with alcohols.	192
Scheme 13.	Photoisomerization of methylenesilacyclobutene <b>4</b> .	194
Scheme 14.	Photoisomerization of 1,4-diphenyl-1,3-butadienes <b>32</b> and <b>31</b> .	195

Scheme 15.	Photoisomerization of 1,4-diphenyl-1,3-butadienes.	195
Scheme 16.	Derivatization of methylenesilacyclobutenes <b>4</b> and <b>33</b> with ethanol.	196
Scheme 17.	Preparation of deuterium labeled methylenesilacyclobutene <b>38</b> .	197
Scheme 18.	Photolysis of methylenesilacyclobutene <b>4</b> in the presence of acetone.	201
Scheme 19.	Thermolysis of methylenesilacyclobutene <b>4</b> .	202
Scheme 20.	Synthesis of methylenegermacyclobutene <b>7</b> .	203
Scheme 21.	Proposed mechanism of cyclization.	204
Scheme 22.	Reactions of methylenesilacyclobutene <b>4</b> .	205



## LIST OF FIGURES

CHAPTER 1. TOWARDS THE SYNTHESIS AND STUDY OF METHYLENE  
GERMACYCLOBUTANES

Figure 1.	Calculated energy profile of <b>28</b> and <b>31</b> .	11
Figure 2.	Energetic profile of the thermal isomerization of <b>1</b> .	14
Figure 3.	Optimized geometry of methylenegermacyclobutane <b>2</b> .	23
Figure 4.	Decomposition of germacyclopent-3-ene <b>57</b> measured in an SFR system.	29

## Appendix. Mass spectra of methylenegermacyclobutanes

Figure 1.	Mass spectrum of 1,1-dimethyl-2-methylenegermacyclobutane ( <b>2</b> ).	51
Figure 2.	Mass spectrum of 1-methyl-1-phenyl-2-methylenegermacyclobutane ( <b>72</b> ).	51
Figure 3.	Mass spectrum of 1,1-diethyl-2-methylenegermacyclobutane ( <b>53</b> ).	52
Figure 4.	Mass spectrum of 1,1-dibutyl-2-methylenegermacyclobutane ( <b>54</b> ).	53
Figure 5.	Mass spectrum of 1,1,3,3-tetramethyl-2,4-dimethylene-1,3-digermacyclobutane ( <b>50</b> ).	54

CHAPTER 2. THERMAL BEHAVIOR OF VARIOUS ORGANOGermanium  
COMPOUNDS

Figure 1.	Energy diagram for the decomposition of germane.	59
Figure 2.	Arrhenius plot of the thermal decomposition of hexylgermane ( <b>48</b> ), over a germanium surface from 440-500 °C following the formation of C <sub>6</sub> hydrocarbons.	95

Figure 3.	Arrhenius plot of the thermal decomposition of dihexylgermane ( <b>49</b> ), over a germanium surface from 480-540 °C following the formation of C <sub>6</sub> hydrocarbons.	98
Figure 4.	Co-pyrolysis of <b>48D</b> and <b>49D</b> over a germanium surface.	101
Figure 5.	Arrhenius plot of the thermal decomposition of trihexylgermane ( <b>51</b> ), over a germanium surface from 550-600 °C, following the formation of C <sub>6</sub> hydrocarbons.	102
Figure 6.	Arrhenius plot of the thermal decomposition of tetrabutylgermane ( <b>17</b> ), over a germanium surface from 580-640 °C following the formation of C <sub>6</sub> hydrocarbons.	106

### CHAPTER 3. EXAMINATION OF THE THERMAL BEHAVIOR OF DIALLYLDIMETHYLGEMANE.

Figure 1.	Arrhenius plot for the thermal decomposition of <b>1</b> following the formation of germacyclopent-3-ene <b>19</b> .	175
-----------	--	-----

### CHAPTER 4. STUDY OF A NOVEL METHYLENESILACYCLOBUTANE

Figure 1.	<sup>1</sup> H NMR spectrum of the products of photolysis of methylenesilacyclobutene <b>4</b> .	193
Figure 2.	<sup>1</sup> H NMR spectrum of 1,4-diphenyl-1,3-butadiene <b>41/40</b> mixture.	198
Figure 3.	Calculated geometry of methylenesilacyclobutene <b>4</b> .	199
Figure 4.	Calculated geometry of methylenesilacyclobutene <b>33</b> .	200

## LIST OF TABLES

CHAPTER 1. TOWARDS THE SYNTHESIS AND STUDY OF METHYLENE  
GERMACYCLOBUTANESCHAPTER 2. THERMAL BEHAVIOR OF VARIOUS ORGANOGERMANIUM  
COMPOUNDS

Table 1.	Static system thermal decomposition rate constants for germane ( <b>1</b> ).	57
Table 2.	Rate constants of thermolysis of germane ( <b>1</b> ) over glass and Ge film.	57
Table 3.	Hydrogen produced in the decomposition of methylgermane-d <sub>3</sub> ( <b>3D</b> ) in the presence of toluene-d <sub>8</sub> .	62
Table 4.	Summary of hydrocarbon yields for the thermal decomposition of methylgermane ( <b>3</b> ) in the presence of toluene-d <sub>8</sub> .	62
Table 5.	Primary processes of methylgermane ( <b>3</b> ) thermal decomposition.	63
Table 6.	Products of decomposition of tetramethylgermane ( <b>11</b> ).	67
Table 7.	Gaseous products of thermolysis of <b>14</b> at 380 °C for 2000 s.	71
Table 8.	Gaseous products from the thermal decomposition of tetraethylgermane ( <b>17</b> ) at 450 °C for 6 h.	74
Table 9.	Gaseous products from the thermal decomposition of tetraethylgermane ( <b>17</b> ) in a semi-flow system, on 10 cm <sup>3</sup> activated charcoal solid carrier.	75
Table 10.	Gaseous products from the thermal decomposition of tetrapropylgermane ( <b>16</b> ) in a semi-flow system on 10 cm <sup>3</sup> activated charcoal solid carrier.	78
Table 11.	Gaseous products from the thermal decomposition of tetrabutylgermane ( <b>19</b> ) in a semi-flow system on 10 cm <sup>3</sup> activated charcoal solid carrier.	78

Table 12.	Products of the flow pyrolysis of dihexylgermylene precursors over a germanium surface.	89
Table 13.	Comparison of Arrhenius parameters to literature results.	96
Table 14.	Arrhenius parameters of some tetralkylgermanes.	108
Table 15.	Products of the flow pyrolysis of dihexylgermylene precursors over a silica surface.	109
Table 16.	Deuterium incorporation in the C <sub>6</sub> hydrocarbons produced from the flow pyrolysis of dihexylgermylene precursors over silica and germanium surfaces.	110

#### Appendix. Deuterium incorporation data

Table 1.	Deuterium incorporation data for hexenes produced from the flow pyrolysis of hexylgermane-d <sub>3</sub> ( <b>48D</b> ) over a germanium coated surface.	153
Table 2.	Deuterium incorporation data for hexenes produced from the flow pyrolysis of dihexylgermane-d <sub>2</sub> ( <b>49D</b> ) over a germanium coated surface.	154
Table 3.	Deuterium incorporation data for hexenes produced from the flow pyrolysis of dihexylgermane-d <sub>2</sub> ( <b>49D</b> ) over a silica surface.	155
Table 4.	Deuterium incorporation data for hexenes produced from the flow pyrolysis of trihexylgermane-d ( <b>51D</b> ) over a germanium coated surface.	156
Table 5.	Deuterium incorporation data for hexenes produced from the flow pyrolysis of trihexylgermane-d ( <b>51D</b> ) over a silica surface.	157
Table 6.	Deuterium incorporation data for hexenes produced from the flow pyrolysis of trihexylgermane ( <b>51</b> ) over a silica surface.	158
Table 7.	Deuterium incorporation data for hexenes produced from the FVP of hexylgermane-d <sub>3</sub> ( <b>48D</b> ) over a germanium coated surface..	159

**CHAPTER 3. EXAMINATION OF THE THERMAL BEHAVIOR OF  
DIALYLDIMETHYLGERMANE.**

Table 1.	Products of the pyrolysis of diallyldimethylsilane ( <b>2</b> ) (1 torr at 723 K).	162
Table 2.	Products from pyrolysis of <b>2</b> (5 torr at 763 K).	163
Table 3.	Volatile products of the flow pyrolysis of allylethylgermanes <b>15-17</b> .	166
Table 4.	Summary of diallyldimethylgermane ( <b>1</b> ) flow pyrolysis experiments.	172

**CHAPTER 4. STUDY OF A NOVEL METHYLENESILACYCLOBUTANE**

Table 1.	Methylenesilacyclobutene <b>4</b> thermolysis conditions and results.	202
----------	---	-----

**ABSTRACT**

In order to further examine the driving forces behind the thermal rearrangement of an olefin to a carbene found in 1,1-dimethyl-2-methylenesilacyclobutane, methylenegermacyclobutanes were synthesized via Barbier-type coupling of 2,4-dibromo-1-butene and dichlorogermanes ( $\text{MeGeCl}_2$ ,  $\text{Et}_2\text{GeCl}_2$ ,  $\text{Bu}_2\text{GeCl}_2$ ,  $\text{PhMeGeCl}_2$ ) with activated magnesium. 1,1-Dimethyl-2-methylenegerma-cyclobutane and 1,1-diethyl-2-methylenegermacyclobutane were synthesized and observed spectroscopically, but could not be isolated due to their decomposition. 1,1-Dibutyl-2-methylenegermacyclobutane and 1-methyl-2-methylene-1-phenylgermacyclobutane were obtained in low yield and could be isolated. Both compounds decomposed at room temperature in air or under argon. The former compound gradually decomposed over a few days, while the latter decomposed overnight. The methylenegermacyclobutanes synthesized were kinetically unstable and tended to decompose, probably through ring opening polymerization. The thermal behavior of 1,1-dibutyl-2-methylenegermacyclobutane was studied and found to be quite complex. Thermal rearrangement to 1,1-dibutyl-1-germacyclopent-3-ene and 1,1-dibutyl-1-germacyclopent-2-ene was observed as a minor pathway. Germylene extrusion is thought to be a major decomposition pathway. However, the expected insertion product of the germylenes into the starting material, 1,1,2,2-tetramethyl-3-methylene-1,2-digermacyclopentane was not observed. Trapping experiments with 2,3-dimethyl-1,3-butadiene similarly did not provide any evidence for the presence of dialkylgermylenes.

In order to further examine the dialkylgermylene proposed to be produced from the thermolysis of 1,1-dibutyl-2-methylenegermacyclobutane, the thermal decomposition of a series of di-*n*-hexylgermylene precursors has been investigated and their Arrhenius parameters compared to literature values where possible. A mechanism of intramolecular  $\beta$  C-H insertion to form an intermediate germirane, followed by either elimination of hexene or a 1,2-hydrogen shift to reform germylene

is proposed. This process allows the migration of germanium up and down the alkyl chain. The presence of the 1,2-hydrogen shift was demonstrated by the observation of deuterium incorporation in the hexenes produced from the deuterium labeled precursors (hexylgermane-d<sub>3</sub>, dihexylgermane-d<sub>2</sub>, and trihexylgermane-d). The mechanisms of the decomposition of these precursors are complex, and most likely include more than one pathway operating simultaneously. Surface effects were observed in the decompositions (over a Ge/C coated reactor) of precursors containing a Ge-H bond. Under those conditions, the distribution of hexene isomers produced was shifted in favor of 1-hexene. It is proposed that a surface reaction which forms a layer of hexylated germanium could occur, and that consecutive elimination of 1-hexene from this layer would explain the relative increase in 1-hexene observed. The proposed mechanism for the decomposition of the dialkylgermylene was further supported by demonstrating the presence of key intermediates. The intermediacy of dialkylgermylene and alkylgermylene was shown by means of trapping experiments with 2,3-dimethyl-1,3-butadiene in the thermolysis of the low temperature germylene precursor ethylmethyl(trimethylsilyl)germane.

The flow pyrolysis of diallyldimethylgermane was also investigated. Arrhenius parameters of  $E_a = 54.2 \pm 0.8$  kcal/mol and  $\text{Log}(A/s^{-1}) = 13.36 \pm 0.2$  were measured. The main decomposition pathway is proposed to be through consecutive Ge-C homolytic cleavage of allyl groups.

The thermal and photolytic behavior of (*Z*)-1,1-dimethyl-2-phenyl-4-(phenylmethylene)silacyclobut-2-ene were studied in the hopes that a rare 1,2-silicon rearrangement to a carbene would be observed. Photolysis at 350 nm or thermolysis in a sealed tube at 250 °C gave the same product, apparently through *cis-trans* isomerization of the external phenylmethylene moiety. Thus, the result was inevitably an inseparable mixture of (*E*)-1,1-dimethyl-2-phenyl-4-(phenylmethylene)silacyclobut-2-ene, and the starting material in a 1:1 ratio. Derivatization of the compounds via alcoholysis for the purposes of characterization produced ring-opened products (*E,Z*)-1,4-diphenyl-1-(ethoxydimethylsilyl)-1,3-butadiene and (*E,E*)-

1,4-diphenyl-2-(ethoxydimethylsilyl)-1,3-butadiene, which also proved to be inseparable.



## GENERAL INTRODUCTION

This dissertation is divided into 4 chapters. Chapters 1, 3, and 4 are organized along the lines of a full paper and include abstract, introduction, results and discussion, conclusion, experimental and reference sections. Chapter 2 is much broader in scope and includes a lengthy introduction and literature survey, results and discussion, conclusion, experimental, reference and appendix section.

Chapter 1 describes the synthesis of a series of methylenegermacyclobutanes and the gas phase thermolysis of 1,1-dibutyl-2-methylenegermacyclobutane. The syntheses were accomplished through the activated magnesium induced Barbier-type coupling of 2,4-dibromo-1-butene and the appropriate dialkyldichlorogermane. Thus, 1,1-Dimethyl-2-methylenegermacyclobutane and 1,1-diethyl-2-methylenegermacyclobutane were synthesized and observed spectroscopically, but could not be isolated due to their decomposition. 1,1-Dibutyl-2-methylenegermacyclobutane and 1-methyl-2-methylene-1-phenylgermacyclobutane were obtained in low yield and could be isolated. The novel germacyclic system 2,4-dimethylene-1,1,3,3-tetramethyl-1,3-digermacyclobutane was synthesized by magnesium homocoupling of ( $\alpha$ -bromovinyl)dimethylchlorogermane, but could not be isolated. Only 1,1-dibutyl-2-methylenegermacyclobutane could be isolated and had a sufficient lifetime for study. The thermal rearrangement of 1,1-dibutyl-2-methylenegermacyclobutane to 1,1-dibutyl-1-germacyclopent-3-ene and 1,1-dibutyl-1-germacyclopent-2-ene was observed as a minor pathway. Germylene extrusion is thought to be a major decomposition pathway. However the expected insertion product of the germynes into the starting material to give 1,1,2,2-tetrabutyl-3-methylene-1,2-digermacyclopentane, was not observed. Trapping experiments with 2,3-dimethyl-1,3-butadiene similarly did not provide any evidence for the presence of germynes.

Chapter 2 describes the synthesis and thermolysis of a series of germanium compounds in order to further examine the mechanism of dialkylgermylene

decomposition. Thus, the thermal decomposition of a series of di-*n*-hexylgermylene precursors was investigated and their Arrhenius parameters compared to literature values where possible. A mechanism of intramolecular  $\beta$  C-H insertion to form an intermediate germirane, followed by either elimination of hexene or a 1,2-hydrogen shift to reform germylene was proposed. This process allows the migration of germanium up and down the alkyl chain. The presence of the 1,2-hydrogen shift was demonstrated by the observation of deuterium incorporation in the hexenes produced from the deuterium labeled precursors (hexylgermane- $d_3$ , dihexylgermane- $d_2$ , and trihexylgermane- $d$ ). The mechanisms of the decomposition of these precursors are complex, and most likely include more than one pathway operating simultaneously. Surface effects were observed in the decompositions (over a Ge/C coated reactor) of precursors containing a Ge-H bond. Under those conditions, the distribution of hexene isomers produced was shifted in favor of 1-hexene. It is proposed that a surface reaction which forms a layer of hexylated germanium could occur, and that consecutive elimination of 1-hexene from this layer would explain the relative increase in 1-hexene observed. The proposed mechanism for the decomposition of the dialkylgermylene was further supported by demonstrating the presence of key intermediates. The intermediacy of dialkylgermylene and alkylgermylene was shown by means of trapping experiments with 2,3-dimethyl-1,3-butadiene in the thermolysis of the low temperature germylene precursor ethylmethyl(trimethylsilyl)germane.

Chapter 3 describes the flow pyrolysis of diallyldimethylgermane (**1**). Arrhenius parameters of  $E_a = 54.2 \pm 0.8$  kcal/mol and  $\text{Log}(A/s^{-1}) 13.36 \pm 0.2$  were measured. The main decomposition pathway is proposed to be through consecutive Ge-C homolytic cleavage of the allyl groups.

Chapter 4 describes the thermal and photolytic behavior of (*Z*)-1,1-dimethyl-2-phenyl-4-(phenylmethylene)silacyclobut-2-ene. Photolysis at 350 nm or thermolysis in a sealed tube at 250 °C gave the same product, apparently through *cis-trans* isomerization of the external phenylmethylene moiety. Thus, the result was inevitably an inseparable mixture of (*E*)-1,1-dimethyl-2-phenyl-4-(phenylmethylene)-

silacyclobut-2-ene and starting material in a 1:1 ratio. Derivatization of the compounds through alcoholysis for the purposes of characterization produced ring opened products (*E,Z*)-1,4-diphenyl-1-(ethoxydimethylsilyl)-1,3-butadiene, and (*E,E*)-1,4-diphenyl-2-(ethoxydimethylsilyl)-1,3-butadiene, which also proved to be inseparable.

## CHAPTER 1. TOWARDS THE SYNTHESIS AND STUDY OF METHYLENE GERMACYCLOBUTANES

### Abstract

In order to further examine driving forces behind the thermal rearrangement of an olefin to a carbene found in 1,1-dimethyl-2-methylenesilacyclobutane,<sup>1,2</sup> methylenegermacyclobutanes were synthesized through Barbier-type coupling of 2,4-dibromo-1-butene and dichlorogermenes ( $\text{MeGeCl}_2$ ,  $\text{Et}_2\text{GeCl}_2$ ,  $\text{Bu}_2\text{GeCl}_2$ ,  $\text{PhMeGeCl}_2$ ) with activated magnesium. 1,1-Dimethyl-2-methylenegermacyclobutane (**2**), and 1,1-diethyl-2-methylenegermacyclobutane (**53**), were synthesized and observed spectroscopically, but could not be isolated due to their decomposition. 1,1-Dibutyl-2-methylenegermacyclobutane (**54**) and 1-methyl-2-methylene-1-phenylgermacyclobutane (**72**) were obtained in low yield and could be isolated. Both compounds decomposed at room temperature in air or under argon, with **54** gradually decomposing over a few days, while **72** decomposed overnight. The novel germacyclic system 2,4-dimethylene-1,1,3,3-tetramethyl-1,3-digermacyclobutane (**50**) was apparently synthesized by magnesium homocoupling of ( $\alpha$ -bromovinyl)-dimethylchlorogermane (**49**). Unfortunately, **50** also was unstable and could not be isolated, but was implicated by GC-MS. The methylenegermacyclobutanes synthesized were kinetically unstable and tended to decompose, probably through ring opening polymerization. Only 1,1-dibutyl-2-methylenegermacyclobutane (**54**) could be isolated and had a sufficient lifetime for study. The thermal behavior of **54** was studied and found to be quite complex. Thermal rearrangement of **54** to 1,1-dibutyl-1-germacyclopent-3-ene (**57**) and 1,1-dibutyl-1-germacyclopent-2-ene (**58**) was observed as a minor pathway. Germylene extrusion is thought to be a major decomposition pathway. However the expected insertion product of the germynes into the starting material to give 1,1,2,2-tetrabutyl-3-methylene-1,2-

digermacyclopentane (**59**), was not observed. Trapping experiments with 2,3-dimethyl-1,3-butadiene similarly did not provide any evidence for the presence of germylenes.

### Introduction

The methylenesilacyclobutane system **1** was found to undergo a unique olefin to carbene isomerization<sup>2</sup>, while the carbon system does not undergo this rearrangement. Since **1** is not a particularly strained system, this rearrangement was quite surprising. The germanium analog **2** might provide insight into this unusual rearrangement, since the role of ring strain and organometal-carbon bond strengths in the rearrangement is not well understood.

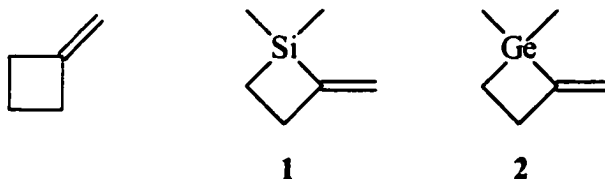

Before the observation of the isomerization of **1**, only a few examples of the thermal isomerization of an olefin to a carbene have been observed, all of which involve very strained olefins. Examples of this isomerization are shown in Scheme 1. Chan and Masuda were able to demonstrate through trapping experiments the presence of the bridgehead olefin **4** and carbene **5** generated from the treatment of **3** with fluoride, the carbene being formed from a 1,2-aryl shift of the bridgehead alkene.<sup>3</sup> Another example was provided by Barton and Yeh, who reported the isomerization of the bridgehead olefin **6** (which was formed thermally) to the carbene **7** through a 1,2-alkyl shift, followed by C-H insertion, giving nortricyclene **8**.<sup>4</sup> Carbene **10** was produced photochemically or thermally from homocubane **9**. Isomerization of **10** to the bridgehead olefin **11**, followed by a 1,2-alkyl shift, gave the carbene **12**. Both products were identified by their ethanol trapping products, **13** and **14** respectively.<sup>5</sup> Other examples include the work of Jones with the parent homocubyl system.<sup>6</sup>

Based on calculations, the barrier for olefin to carbene isomerization is quite high. Therefore, it is not surprising that few examples of this isomerization exist and those that do exist involve strained olefins. The barrier for the isomerization of ethylene to methylcarbene was calculated to be between 74.2 and 82.1 kcal/mol,<sup>7,8</sup> while the barrier for the reverse reaction was calculated as being 0.8 kcal/mol.<sup>9</sup>

Scheme 1. Examples of olefin to carbene isomerization.

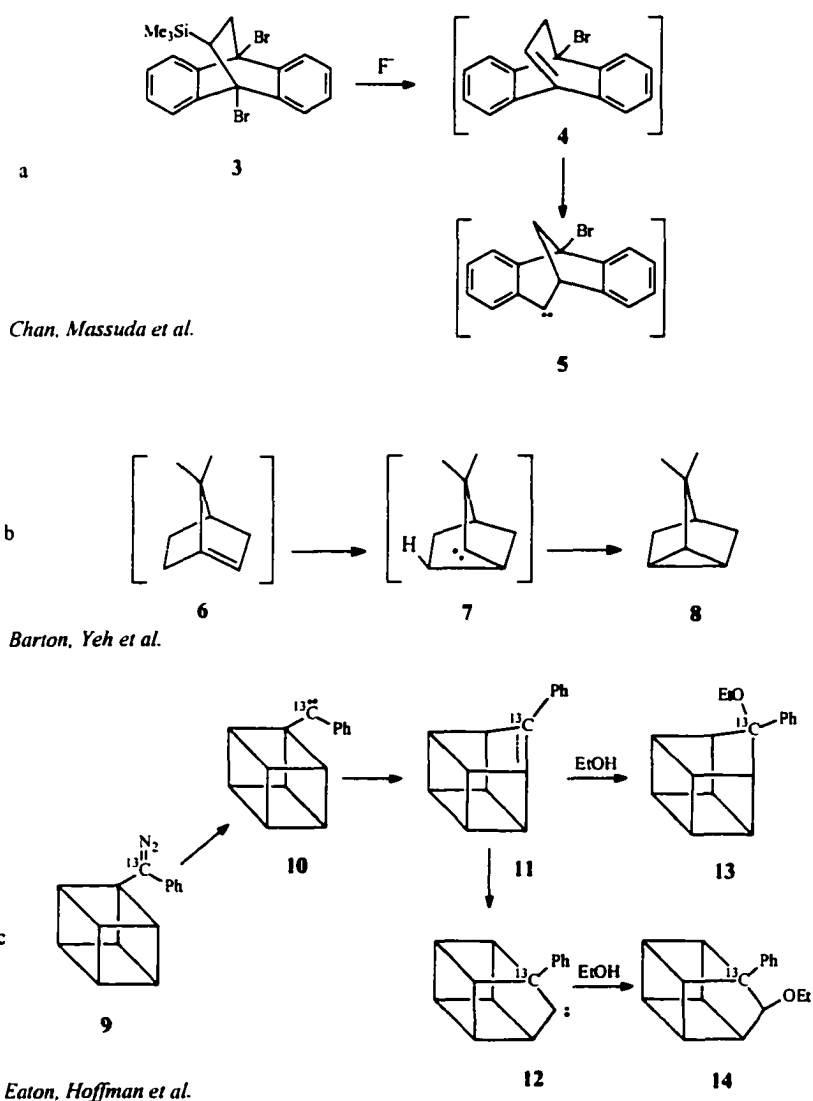

The synthesis and thermal behavior of 1,1-dimethyl-2-methylene-silacyclobutane (**1**) was first reported by Conlin (Scheme 2).<sup>1</sup> The low pressure flow pyrolysis of 1,1-dimethylsilacyclobutane (**15**) at 600 °C with an excess of allene gave the 2+2 adduct of silene and allene, methylenesilacyclobutane **1**. Other products were also observed; among them were 1,1-dimethylsilacyclopent-3-ene (**16**) and 1,1-dimethylsilacyclopent-2-ene (**17**).

Scheme 2. Synthesis of methylenesilacyclobutane **1**.<sup>1</sup>

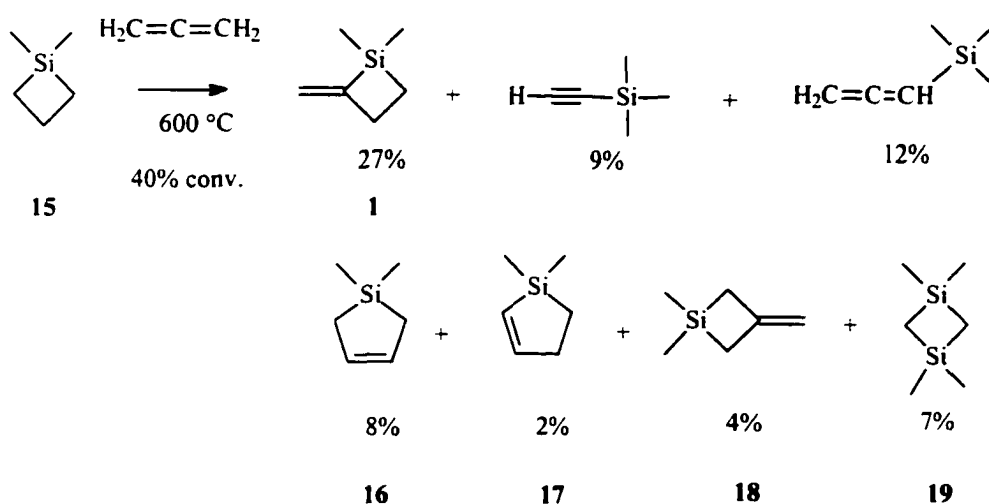

A different product distribution was obtained at 670 °C; a 4% yield of **1** was obtained, a large increase in the yield of silene dimerization product **19** (38% at 670 °C), and the yields of **16** and **17** were almost doubled. The formation of the silacyclopentenes could only be explained as being secondary thermal products of **1**. This was confirmed by the independent pyrolysis of **1** performed at 421 °C in a fused salt bath. The product silacyclopentenes **16** and **17** were obtained in quantitative yield.

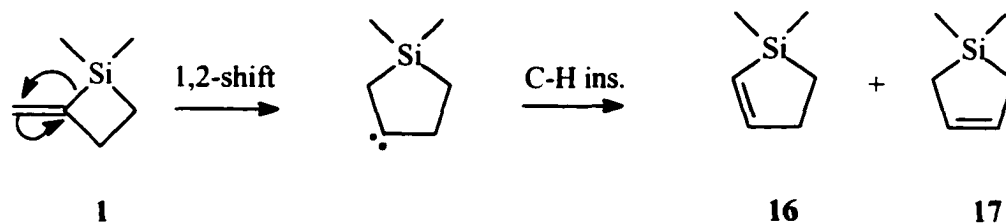
Scheme 3. Pyrolysis and proposed mechanism of methylenesilacyclobutane **1**.<sup>1</sup>

The most likely mechanism was daringly proposed to be a Si-C migration to the methylene giving a carbene  $\beta$  to the silicon. A hydrogen shift would then give either **16** or **17** (Scheme 3). Around the same time Barton and Groh were examining the thermal rearrangement of *o*-(dimethylsilyl)phenylacetylene to silaindenes.<sup>10</sup>

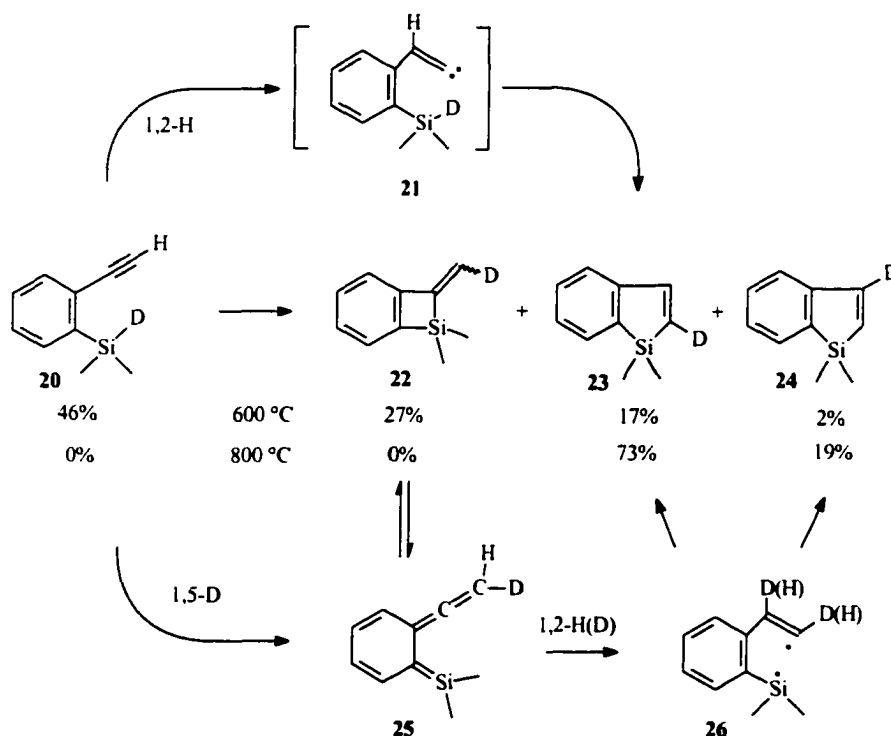
Scheme 4. Pyrolysis of *o*-(dimethylsilyl)phenylacetylene **20**.<sup>10</sup>

They found that the rearrangement produced three products, the silaindenes **23** and **24** and the methylenebenzosilacyclobutane **22** (Scheme 4). The proposed mechanism involved two pathways; the 1,2-H shift to the vinylidene **21**, followed by Si-D insertion, giving **23**, or a 1,5-D shift to produce allene **25**. Intramolecular 2+2



addition of **25** would give **22**, or a 1,2-H(D) shift could occur giving the diradical **26**. Closure of the diradical would give **23** and **24**. However, in light of the reported isomerization of **1** by Conlin (that was published later), it is likely that an intermediate carbene **27** could be involved as shown in Scheme 5.

Scheme 5. Isomerization of methylenebenzosilacyclobutane **22**.

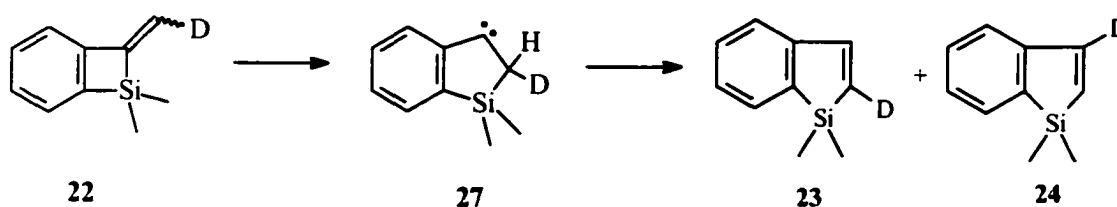

The unexpected product of an attempted synthesis of silylenevinylene polymers provided a molecule that is perfectly set up to undergo this unusual olefin to carbene isomerization. Scheme 6 shows the magnesium coupling of ( $\alpha$ -bromovinyl)dimethylchlorosilane, giving mainly dimer **28**.<sup>2</sup>

Scheme 6. Synthesis of dimethylenedisilacyclobutane **28**.<sup>2</sup>

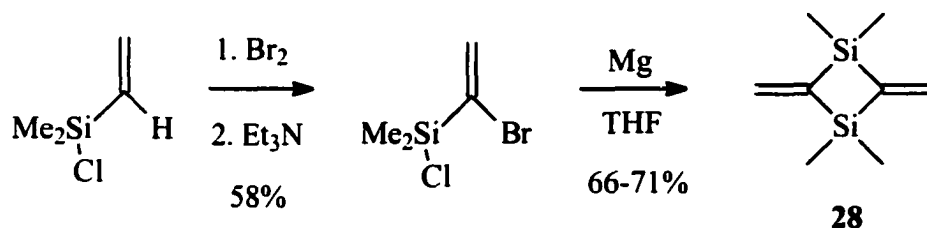

When **28**, subjected to flow pyrolysis at 600 °C, the ring expanded product **29** was obtained. The isomerization was clean and kinetic studies done in an SFR system provided Arrhenius parameters ( $E_a = 54.09$  kcal/mol, log A of 12.48) for the isomerization. These numbers are consistent with the proposed route for concerted ring expansion through a carbene, and effectively rule out Si-C homolysis (Scheme

7). No double ring expansion product **30** was observed even at elevated reaction temperatures, suggesting that ring strain contributes to this isomerization.

However, the all carbon analog of **28** does not exhibit this isomerization, suggesting that the observed behavior is due to silicon.

Scheme 7. Pyrolysis of dimethylenedisilacyclobutane **28**.<sup>2</sup>

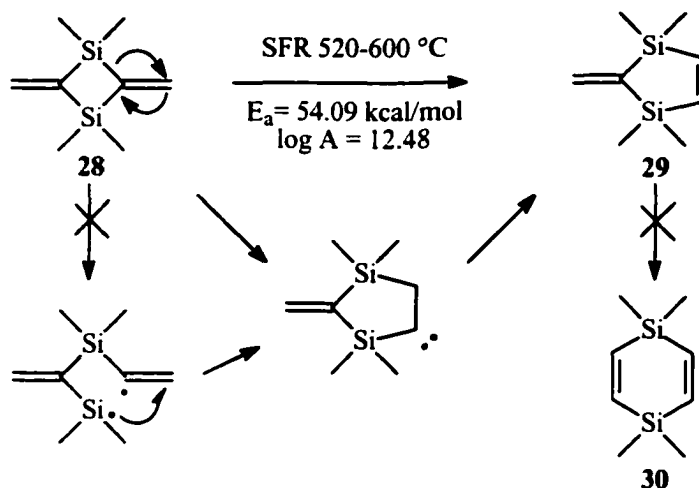

To elucidate the role of ring strain in this system, homodesmotic reactions<sup>11</sup> were used to calculate the ring strain of the various products and intermediate carbenes (Scheme 8). According to the calculations, except for the ring strain of the carbene intermediates, the ring strains of the other ring systems are comparable. The carbon system actually relieves more ring strain upon ring expansion to the carbene (28.5 kcal) than the silicon system (13.8 kcal)! Of course, this result is contrary to the observed results. However, calculations of the transition states involved in the two systems show important and revealing differences. Further calculations (with electron correlation) show that the silacyclic system has a 60.8 kcal barrier to the carbene (Figure 1), which is actually the transition state and not an intermediate. The hypothetical isomerization of the carbocyclic system has a 74.3 kcal barrier to the intermediate carbene, with the back reaction having a barrier of 24.9 kcal. Therefore, the late transition state of the silacyclic system and the early and high transition states of the carbocyclic system must explain the differences in thermal behavior.

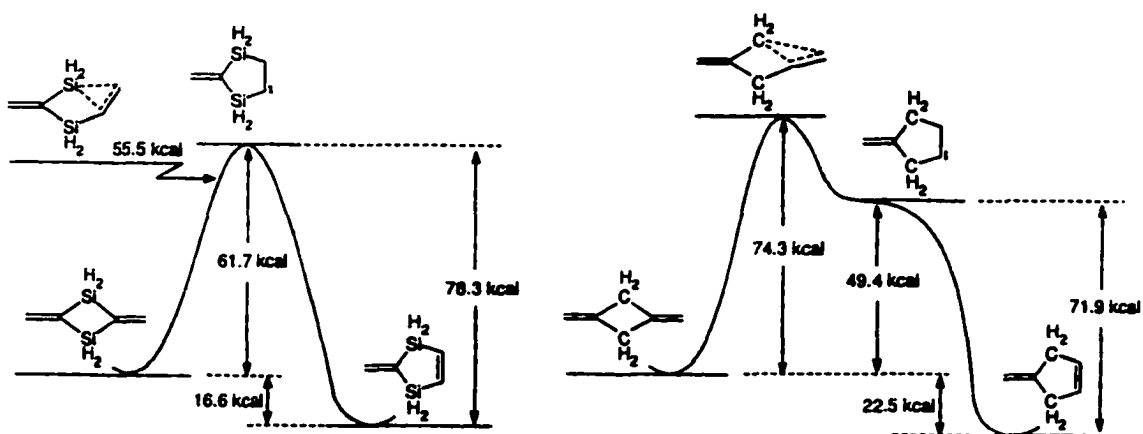
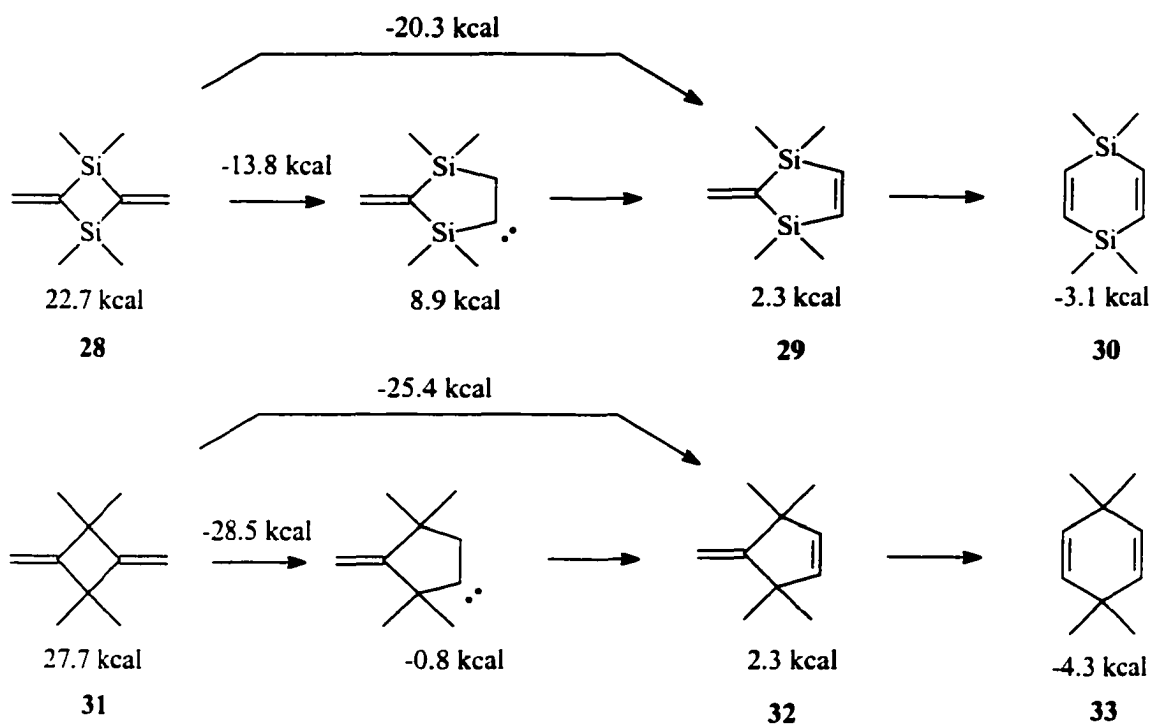
Scheme 8. Calculated ring strains.<sup>2</sup>Figure 1. Calculated energy profile for parent systems of **28** and **31**.<sup>2</sup>

The report of Conlin and the examination of **28** led Barton and coworkers to examine carefully the reported thermal isomerization of **1**. The thermal rearrangement of **1** is very surprising considering the thermal behavior of similar ring systems. Scheme 9 shows a summary of the thermal decomposition and Arrhenius data for related ring systems. In the case of cyclobutane (**34**),<sup>12</sup> and 1,1-dimethylsilacyclobutane (**15**),<sup>13</sup> decomposition is through homolytic cleavage of a C-C bond giving ethylene or ethylene and silene respectively. The all-carbon analog of **1**, methylenecyclobutane (**35**)<sup>14</sup> decomposes in a similar fashion, giving ethylene and allene. The Arrhenius parameters of these processes are all very similar, with an activation energy of around 63 kcal/mol and log A of around 15.6.

Scheme 9. Thermal decomposition and Arrhenius parameters for related systems.

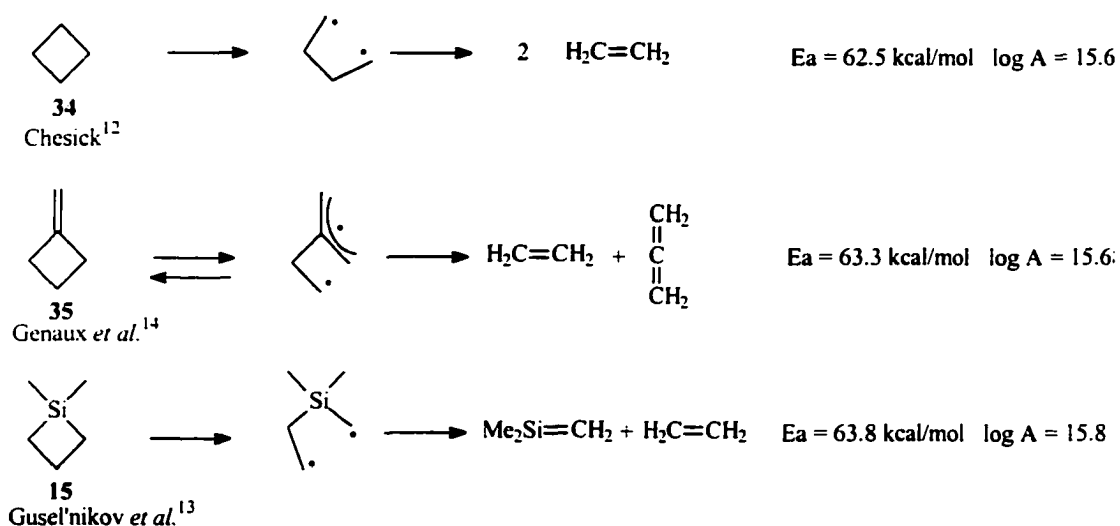

In order to measure the kinetics of the isomerization reported by Conlin, Barton and coworkers developed a new synthetic route to **1**, since the method of Conlin could not be reproduced (Scheme 10). The kinetics of the thermal isomerization of **1** were then measured in an SFR reactor over the temperature range of 530 °C-590 °C (Scheme 11).<sup>2</sup>

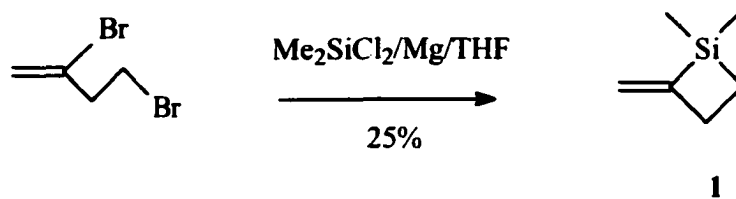
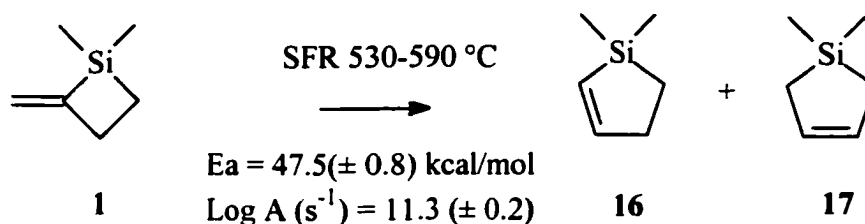
Scheme 10. Synthesis of methylenesilacyclobutane **1**.<sup>2</sup>Scheme 11. SFR pyrolysis of methylenesilacyclobutane **1**.<sup>2</sup>

The formation of the products **16** and **17** apparently proceed through a concerted mechanism since  $\log A = 11.3$ . Furthermore the  $\Delta S_{\text{act}} = -10.7$  suggesting a constrained intermediate. The activation energy of 47.5 kcal/mol is similar to the energy of a  $\pi$  bond, which is reasonable considering the rate determining step of the mechanism is essentially the breaking of a  $\pi$  bond. The kinetic results are therefore consistent with the mechanism originally proposed by Conlin, that is the 1,2-silyl shift to form a carbene, which undergoes C-H insertion, giving either silacyclopent-3-ene **16** or silacyclopent-2-ene **17**.

The labeled precursor **1D** was utilized to determine if nonproductive ring opening was occurring (Scheme 12). Deuterium scrambling between the allylic methylene and terminal vinyl position was observed upon pyrolysis at 601 °C, a temperature below that required for significant olefin isomerization.

Scheme 12. Deuterium scrambling of the pyrolysis of methylenesilacyclobutane **1D**.<sup>2</sup>

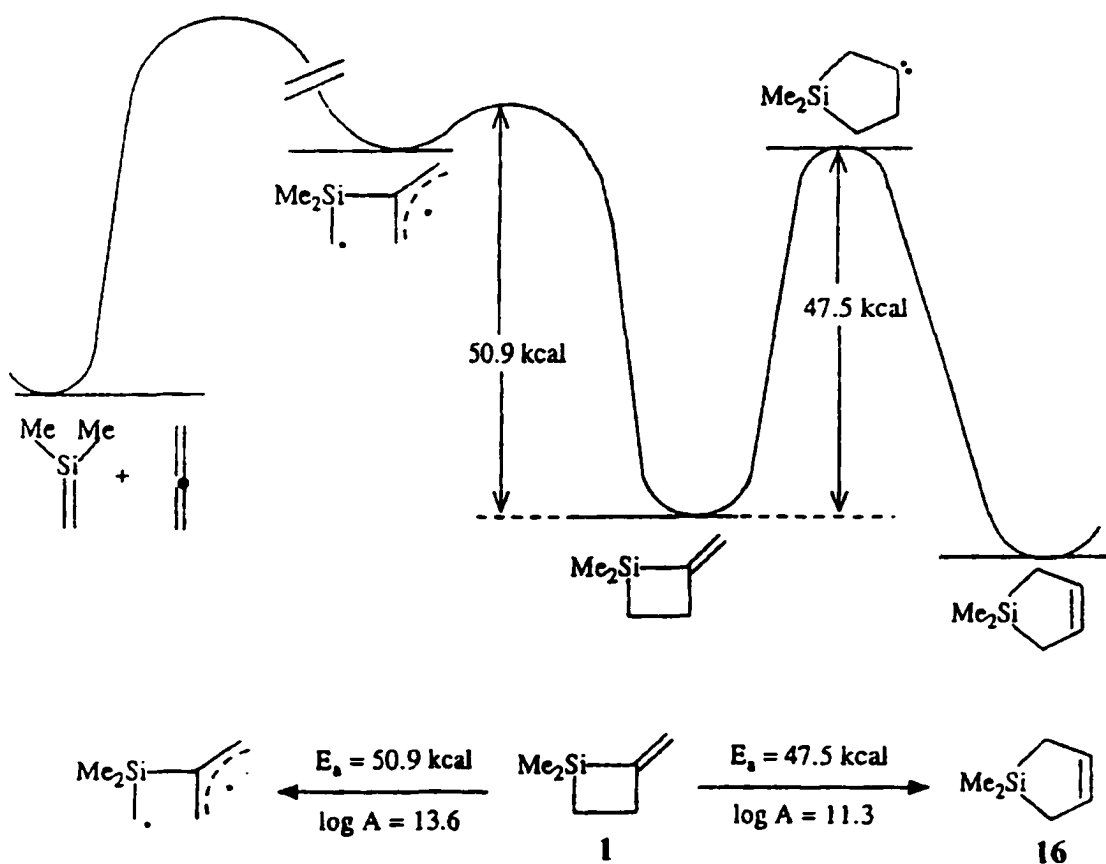
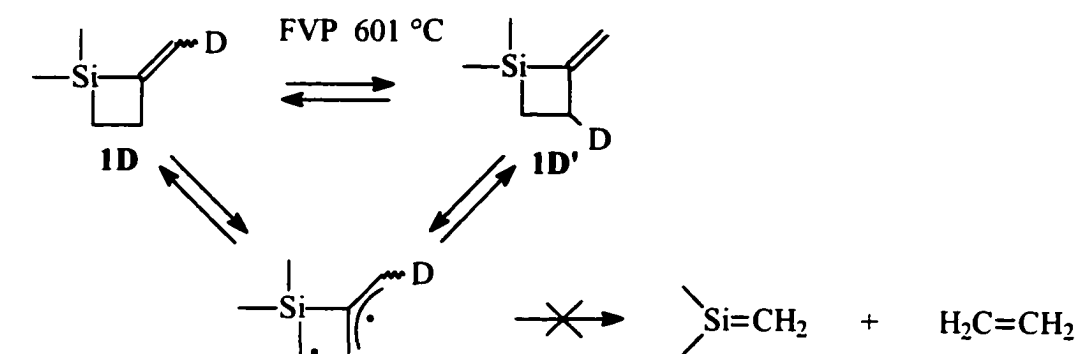
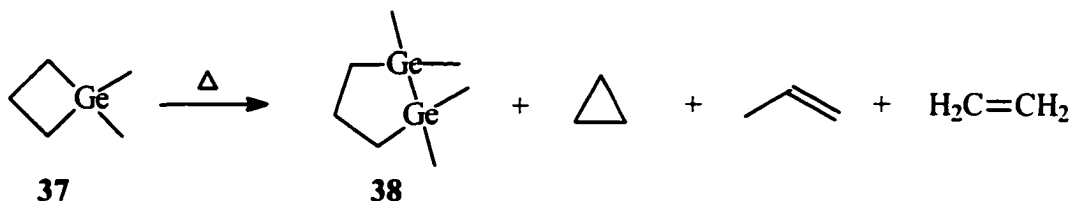

Figure 2. Energetic profile of the thermal isomerization of **1**.<sup>2</sup>

The kinetics of the conversion of **1D** to **1D'** were examined over the temperature range of 460-530 °C. Samples were collected in cooled NMR tubes after pyrolysis at the appropriate temperature in an SFR system, then analyzed by  $^2\text{H}$  NMR spectroscopy. By utilizing a rate expression derived from the model of Davidson,<sup>15</sup> the Arrhenius parameters of the formation of **1D'** were obtained ( $E_a = 50.85$  kcal/mol,  $\log A = 13.56$ ). The deuterium isomerization has a slightly higher activation energy, but because deuterium scrambling through ring cleavage and reformation is more entropically favorable, it can be observed at lower temperatures than olefin isomerization. An energetic profile proposed by Barton and coworkers for the thermal isomerization of **1** is shown in Figure 2. The underlying reasons for the unusual behavior of **1** is not readily apparent. However, it appears that ring strain alone is not the driving force for this isomerization since the carbon analog does not exhibit this isomerization. In addition, a higher barrier to the intermediate carbene for the carbon system (as shown in calculations for **28**) may preclude isomerization in favor of fragmentation to ethylene and allene.

The germanium analogs of silacyclobutene **15**, 2,4-dimethylene-silacyclobutane **28**, and methylenesilacyclobutene **1**, are not known compounds. However, several 1,1-disubstituted germacyclobutanes are known.<sup>16</sup> The parent 1,1-dimethylgermacyclobutane (**37**) has been synthesized and its thermal behavior studied. Gusel'nikov and coworkers first pointed out the gas phase pyrolysis of 1,1-dimethylgermacyclobutane differed significantly from its silicon analog (Scheme 13).<sup>17</sup>

Scheme 13. Pyrolysis of germacyclobutane **37**.<sup>17</sup>



The pyrolysis of **37** produced cyclopropane, propene, ethylene, and 1,1,2,2-tetramethyl-1,2-digermacyclopentane **38**. The presence of the digermene **38** was evidence for the formation of dimethylgermylene, since it is an insertion product of the germylene back into the starting material. 1,1,3,3-Tetramethyl-1,3-digermacyclobutane (**41**) was not produced, suggesting that a germene is not produced in the pyrolysis, since it would be expected to undergo head-to-tail dimerization.

Scheme 14. Trapping studies of germacyclobutane **37** with 1,3-butadiene.<sup>18</sup>

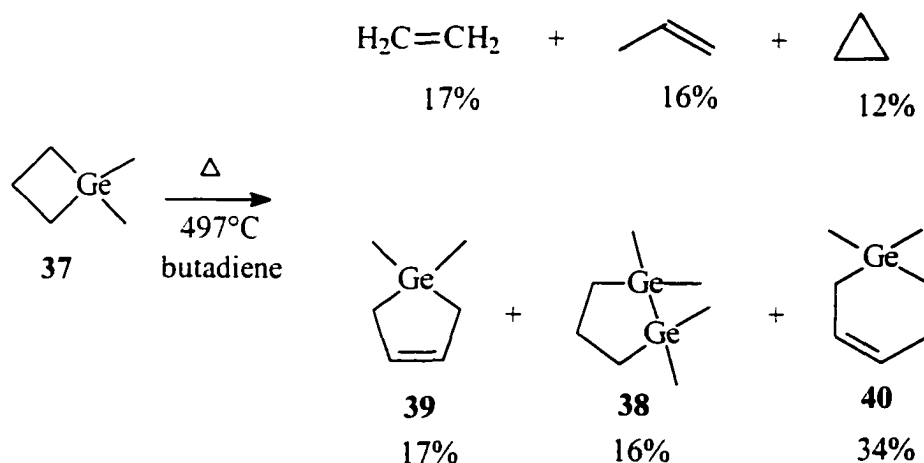

The mechanism of the thermal decomposition of **37** was examined by Conlin.<sup>18</sup> To confirm the presence of dimethylgermylene and other intermediates, trapping studies were performed (Scheme 14). Flow pyrolysis in the presence of 1,3-butadiene gave the trapping product 1,1-dimethyl-1-germacyclopent-3-ene (**39**), confirming the presence of dimethylgermylene. Also observed was 1,1-dimethyl-germacyclohex-3-ene (**40**), apparently indicating the presence of dimethylgermene. Conlin was also able to find small amounts of 1,1,3,3-tetramethyl-1,3-germacyclobutane (**41**) (around 4%) in the neat pyrolysis of **37**, confirming the presence of dimethylgermene in the pyrolysis.

The results obtained by Conlin show behavior for the germacycle much different and more complex than that of its silicon analog. A general scheme for the



decomposition of **37** is shown in Scheme 15. Apparently, germacyclobutane can undergo either elimination to form germene and ethylene, or extrusion of germynes giving cyclopropane and propene. The source of propene is not evident, since cyclopropane does not yield significant amounts of propene at the temperatures involved in the experiments.<sup>18</sup>

Kinetic experiments undertaken in a static vessel over the temperature range of 416–478 °C were performed by Conlin. Using a steady state approximation for germylene, the following rate expression can be obtained, which describes the observed rate constant for the disappearance of **37**. The Arrhenius parameters were then obtained for two modes of decomposition.

$$k_{\text{obs}} = k_1 + 2k_2$$

*fragmentation to germene*       $E_a = 63.1(\pm 0.4) \text{ kcal/mol}$      $\log A = 14.7$

*extrusion of germylene*       $E_a = 60.7(\pm 0.3) \text{ kcal/mol}$      $\log A = 14.1$

Scheme 15. Decomposition of germacyclobutane **37**.<sup>18</sup>

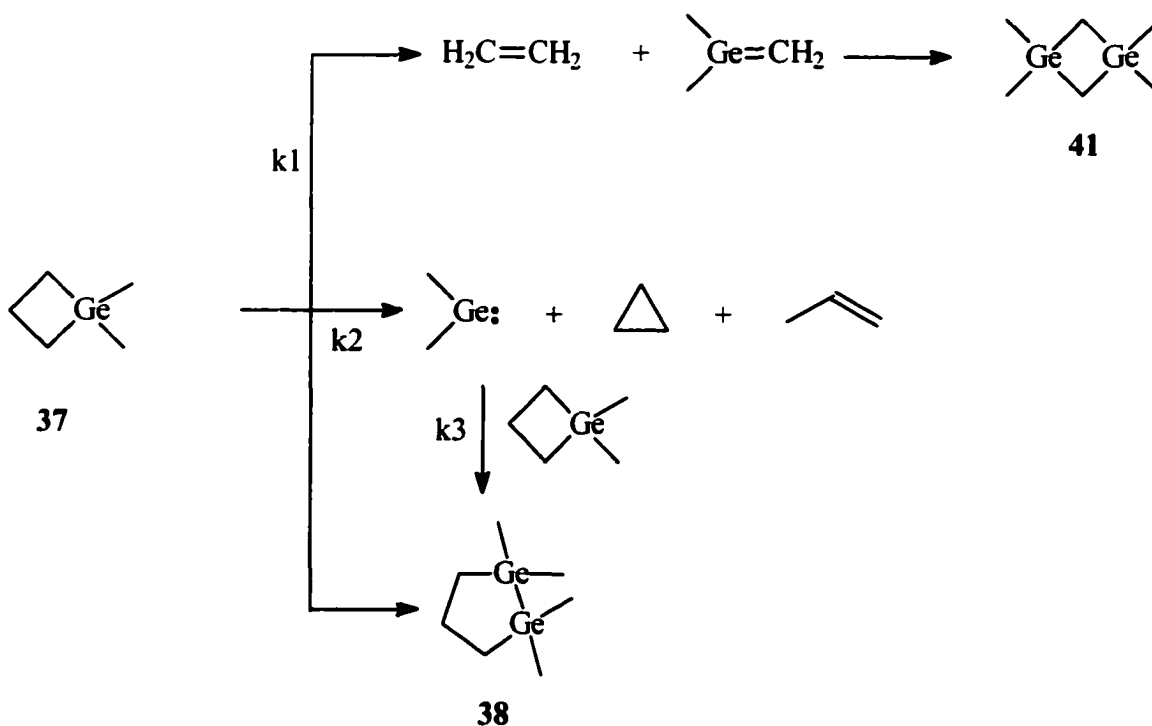

These numbers are very close to those reported for the silicon and carbon analogs, despite the complex mechanism suggested by the trapping experiments. The activation energy obtained for fragmentation to germene is reasonable if a germanium-carbon bond strength of 83 kcal/mol (reported values for Ge-C bonds vary from 76-83 kcal/mol<sup>19-21</sup>) and a ring strain of 20 kcal/mol are assumed, giving a 63 kcal/mol barrier. However, there is the possibility of initial C-C bond cleavage, especially considering that the silicon analog is believed to decompose through C-C bond cleavage.<sup>22</sup> This C-C bond cleavage could not be ruled out. Conlin proposed a mechanism, shown in Scheme 16, to explain the production of propene. Initial cleavage of the Ge-C bond gives the common intermediate diradical **42**.

Scheme 16. Proposed mechanism for the decomposition of germacyclobutane **37**.<sup>18</sup>

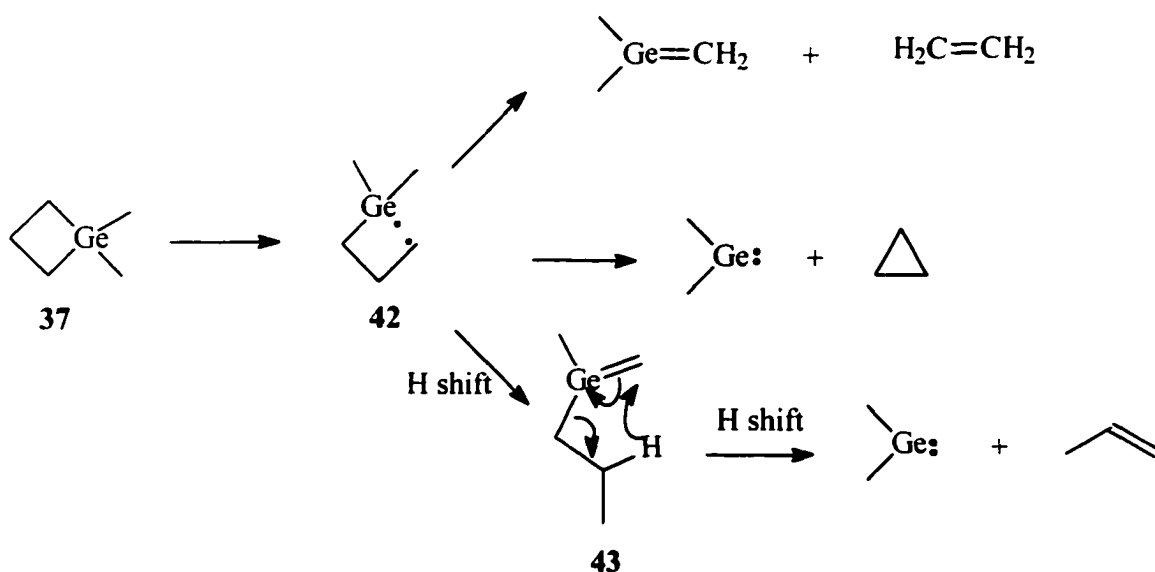

From the diradical **42**, fragmentation gives dimethylgermene and ethylene, while displacement yields dimethylgermylene and cyclopropane. Propene is thought to be produced after consecutive H-shifts. First a 1,5-H shift from a germanium methyl to the terminal alkyl radical would give the germene intermediate **43**. A rearrangement involving a 1,3-H shift could then produce propene and dimethylgermylene. While the studies outlined earlier show that propene formation

from *ground state* cyclopropane does not yield significant amounts of propene, it should be noted that the propene may be formed from the decomposition of *vibrationally excited* cyclopropane, thus making this questionable H shift mechanism unnecessary.

## Results and Discussion

The 2-methylenegermacyclobutane class of molecules proved to be a very difficult synthetic target. The first attempts towards synthesis were based on the synthesis of the silicon analog, 1,1-dimethyl-2-methylenesilacyclobutane (**1**), which could be synthesized in good yield through simple magnesium coupling of 2,4-dibromo-1-butene and dimethyldichlorosilane. The dibromo compound **36** was prepared according to the literature method<sup>2</sup> by the reaction of homopropargyl alcohol with hydrogen bromide, followed by bromination with phosphorous tribromide. Unfortunately, repeated attempts at magnesium induced coupling of **36** and dimethyldichlorogermane failed to produce any of the desired compound (Scheme 17), instead yielding only polymeric materials.

Scheme 17. Attempted synthesis of methylenegermacyclobutane **2**.

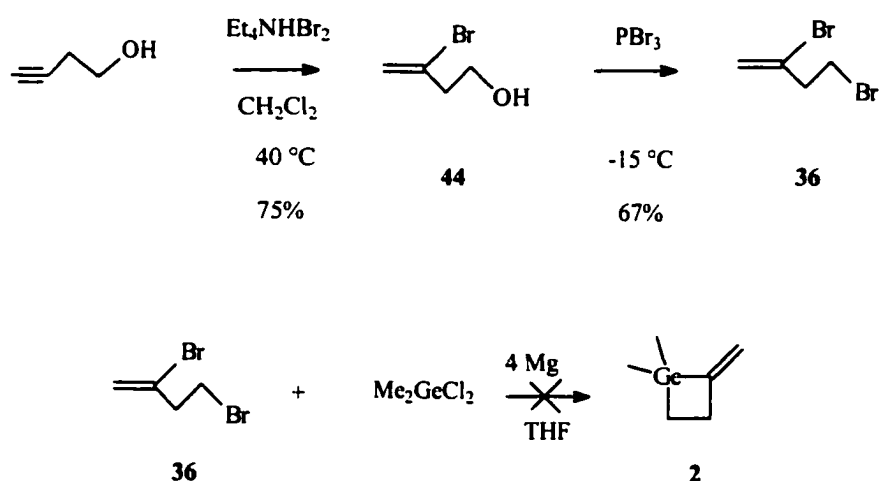

Another possible route to the target system is the bimolecular coupling of ( $\alpha$ -bromovinyl)dimethylchlorogermane **49**, which would give 2,4-dimethylene-1,1,3,3-tetramethyl-1,3-digermacyclobutane (**50**). This route is advantageous because homocoupling of the separate reactants is not a concern. However, there is the problem of stability. If a single methylene group adds significant strain to the molecule, then two methylene groups will only exacerbate the problem. The synthesis of the appropriate precursor **49** is outlined in Scheme 18. First, a diethylamino blocking group is added through the condensation of diethylamine with dimethyldichlorogermane (**45**), giving (diethylamino)dimethylchlorogermane (**46**). Next, the addition of a vinyl group, followed by deprotection gives the precursor dimethylvinylchlorogermane (**48**).

Scheme 18. Synthesis of dimethylenedigermacyclobutane **50**.

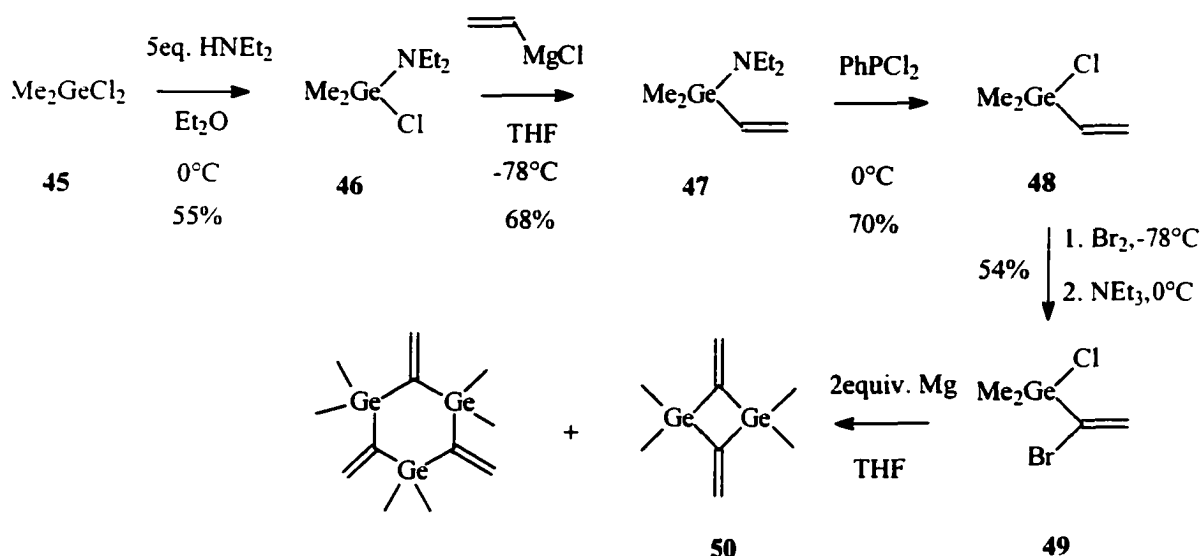

Bromination followed by treatment with triethylamine gives ( $\alpha$ -bromovinyl)-dimethylchlorogermane (**49**). The magnesium homocoupling of **49** seemed to proceed cleanly, with the trimer also being produced, and the compound could be observed by GC-MS (see Figure 5 in the Appendix, for the mass spectrum of **50**).

However, when isolation was attempted through distillation, the molecule disappeared, perhaps through ring opening polymerization, the apparent result of kinetic instability. Thus, we returned to the route of coupling the dibromo compound **36** with various chlorogermanes. It was hoped that the use of activated magnesium would allow ring formation, rather than homocoupling or polymer formation.

Scheme 19 shows the Barbier-type coupling of **36** with various dialkyldichlorogermanes through activated magnesium made from the reduction of anhydrous magnesium chloride with potassium metal.<sup>23</sup> The first attempt utilized dimethyldichlorogermane (**45**) and seemed to be successful. A compound corresponding to germacycle **2** was observed by GC-MS after work-up as the only germanium containing product. However when the solvent (pentane) was removed by distillation through a 15 cm Vigreux column at atmospheric pressure, decomposition/polymerization occurred with total loss of **2** (see Figure 1 in the Appendix for the mass spectrum of **2**).

Scheme 19. Activated magnesium coupling of dibromobutene **36** and dialkyldichlorogermanes.

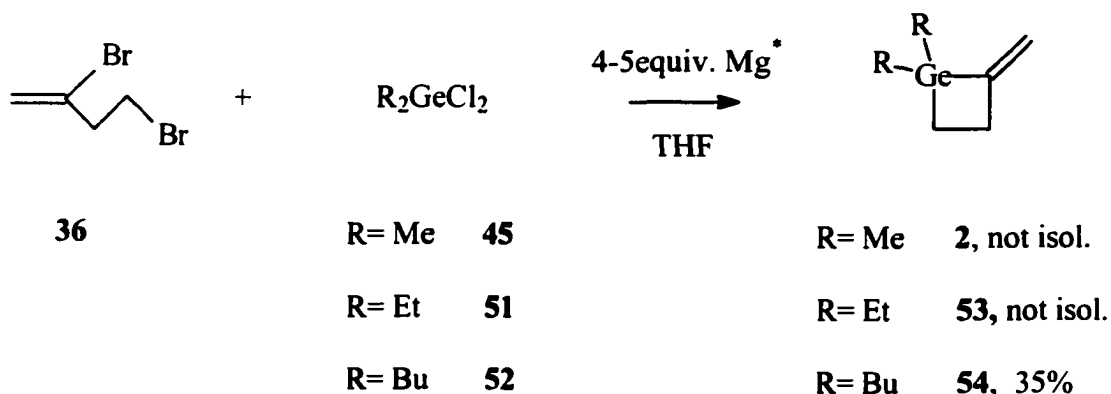

Since **2** could not be isolated, other germanium compounds were chosen in the hopes that longer *n*-alkyl groups germanium would hinder the decomposition process. Thus, diethyldichlorogermane (**51**) and dibutyldichlorogermane (**52**) were used in the reaction. Scheme 20 shows the synthesis of dibutyldichlorogermane

(52) and diethyldichlorogermane (51) through a redistribution reaction of the respective tetraalkylgermane with 2-chloropropane and aluminum trichloride. This method is a modification of that of Mirinov, who used the same catalyst system, but with only 0.02 equivalents of aluminum trichloride to remove one methyl group from tetramethylgermane, giving trimethylchlorogermane.<sup>24</sup> With the use of 0.2 equivalents of aluminum trichloride, the method is selective for the dialkyldichlorogermane, and seems to be general for tetraalkylgermanes.

Scheme 20. Synthesis of diethyldichlorogermane (51) and dibutyldichlorogermane (52).

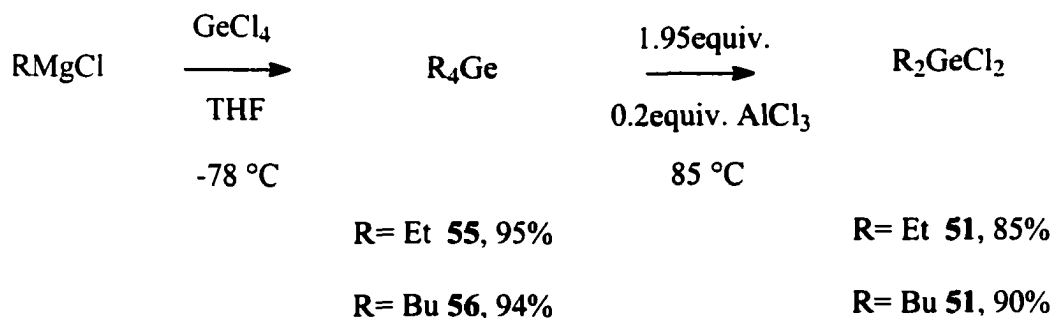

The ethyl substituted product, **53**, was also observed by GC-MS after work-up. However, it could not be isolated due to decomposition to an oil (see Figure 3 in the Appendix for the mass spectrum of **53**). 1,1-Dibutyl-2-methylenegermacyclobutane (**54**), on the other hand survived solvent removal by rotary evaporation and was isolated by flash chromatography (hexane, silica gel). However, it too was susceptible to decomposition, which occurred most readily when neat. The compound could survive for several days if kept in solution in the freezer (see Figure 4 in the Appendix the for mass spectrum of **54**).

Geometry optimization calculations (AM1) for **1**, **53**, and **54** all show the same planar geometry with no changes in internal bond angles (the optimized geometry of **1** is shown in Figure 3) due to substituent effects. The structure reveals a possible explanation for the kinetic instability of the 2-methylenegermacyclobutane moiety.

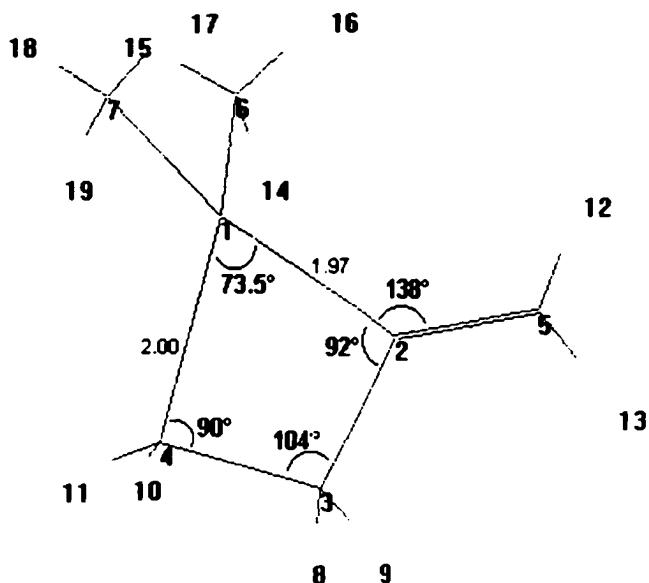
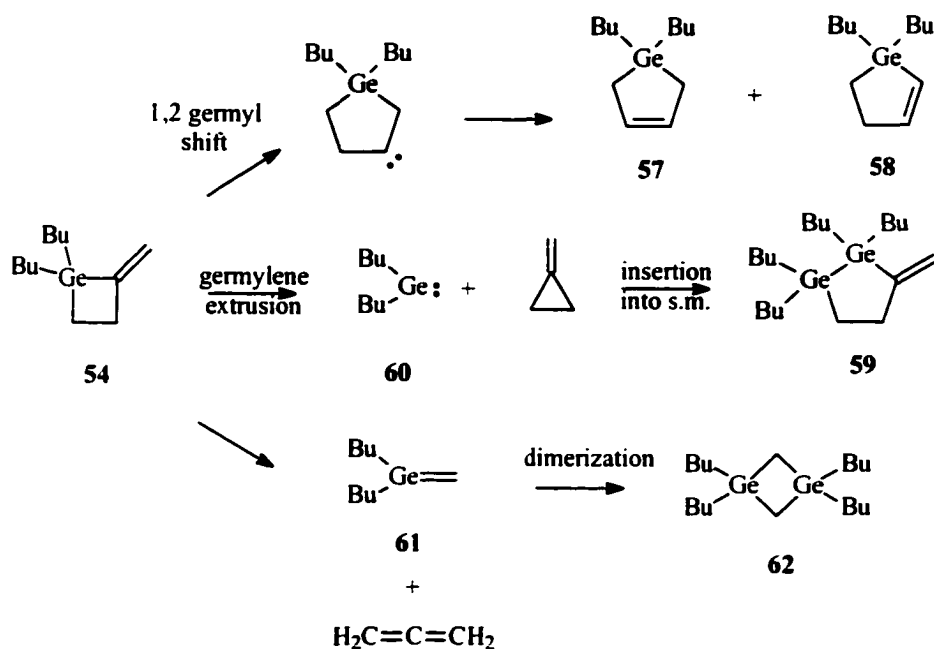

Figure 3. Optimized geometry of methylenegermacyclobutane **2**.

The geometry around the internal  $sp^2$  carbon is very distorted, supplying a driving force for ring opening. It is possible that the action of adventitious base facilitates ring opening, and the bulkier butyl groups provide a degree of shielding for this labile Ge-C bond, thus hindering ring opening.

Taking into account the literature routes for the decomposition of germacyclobutanes shown earlier, and the proposed ring expansion, the expected decomposition routes for **54** are outlined in Scheme 21. Besides the thermal ring expansion giving germacyclopentenes **57** and **58**, extrusion of dibutylgermene **60** as well as the formation of dibutylgermene **61**, was expected. The eventual products from the latter two processes were expected to be digermacyclopentane **59** (through the insertion of germynes into the starting material) and digermacyclobutane **62** (from the dimerization of dibutylgermene).

Scheme 21. Decomposition pathways of methylenegermacyclobutane **54**.

Having finally made a suitable compound for study, **54** was subjected to flow pyrolysis and SFR (Stirred Flow Reactor) pyrolysis. In the SFR (over the temperature range 440 °C to 520 °C), the compound seemed to isomerize cleanly to the expected isomers: 1,1-dibutyl-1-germacyclopent-3-ene (**57**) and 1,1-dibutyl-1-germacyclopent-2-ene (**58**) (Scheme 22). The compounds were identified by GC-MS analysis of the products of flow pyrolysis and comparison to known authentic samples. No other volatile germanium-containing compounds were observed.

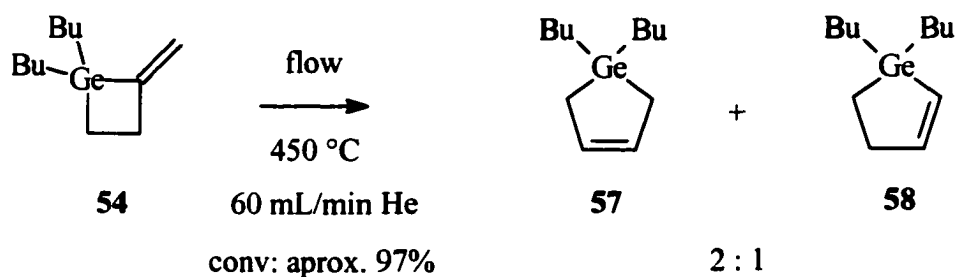
Scheme 22. Pyrolysis of methylenegermacyclobutane **54**.



Therefore, as seen in Scheme 21, there is no direct evidence for the extrusion of germylenes since the expected insertion product **59** was not observed. Similarly, the dibutylgermene dimerization product **62** also was not observed. However, attempts at measuring the kinetics of the reaction revealed that other processes *were* involved, since the starting material was decomposing, yet the amount of the isomers **57** and **58** was not increasing beyond a certain point. This suggests that another route for decomposition is active apart from the observed ring expansion to germacyclopentenes. However, attempts to trap any germylenes generated during the pyrolysis with 2,3-dimethyl-1,3-butadiene were unsuccessful.

It was a possibility that the products, themselves being thermally labile, were decomposing under the reaction conditions. To examine this, the appropriate isomers were synthesized. Germacyclopentene **57** was synthesized according to the literature route shown in Scheme 23.<sup>25</sup>

Scheme 23. Synthesis of germacyclopent-3-ene **57**.

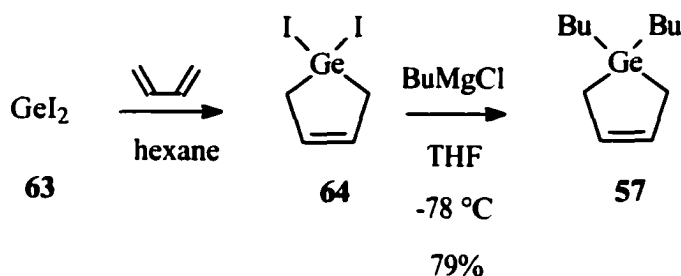

The 1,1-dibutyl-1-germacyclopent-2-ene isomer (**58**) was synthesized by the somewhat longer route shown in Scheme 24. First, (*Z*)-1,4-dibromo-1-butene **69** was made by reduction of the bromoacetylene **66** with diazene, followed by deprotection and bromination of the alcohol **68** with phosphorous tribromide.

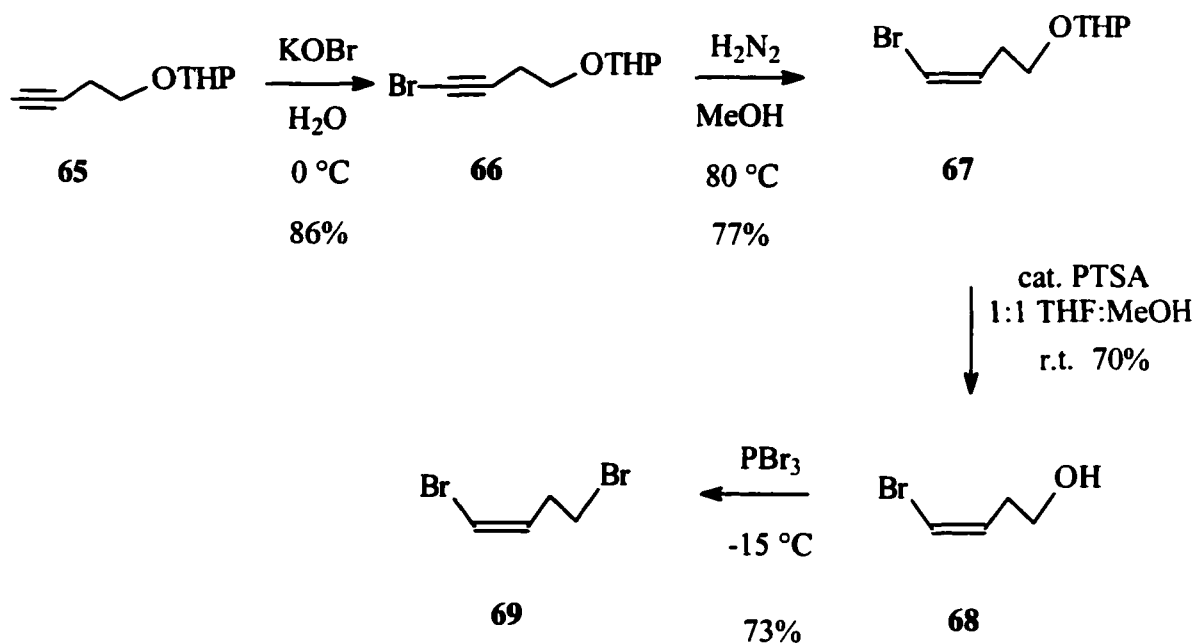
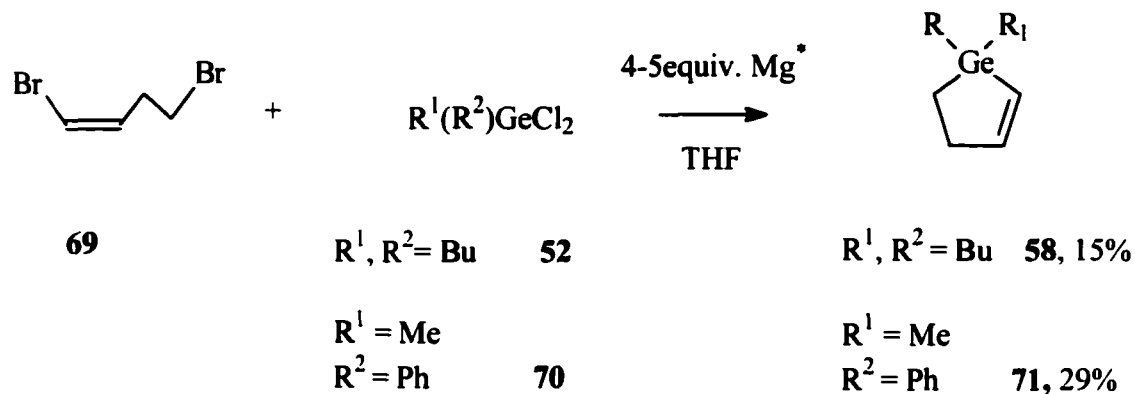
Scheme 24. Synthesis of dibromobutene **69**.Scheme 25. Synthesis of germacyclopent-2-enes **71** and **58**.

Next, **69** was utilized to synthesize the target through activated magnesium coupling with dibutyldichlorogermane (**52**) or methylphenyldibromogermane **70**, giving **58** and **71** respectively. The products were isolated by flash chromatography as clear liquids, although in poor yields (Scheme 25). Methylphenyldibromogermane

(70) was synthesized by reacting 2 equivalents of bromine with methyltriphenylgermane in bromoethane at room temperature for 11 days.

The thermal stability of the compounds **58** and **71** was studied by SFR over the temperature range 400 °C to 700 °C. The compounds displayed no significant decomposition up to 550 °C. At 600 °C conversion was only 23% (based on internal standard calculation of the remaining starting material). No new germanium-containing compounds were produced, only hydrocarbons were observed.

Thus, the germacyclopent-2-ene isomer **58** produced in the thermal rearrangement of **54** is quite stable over the range of temperatures in question. However, the germacyclopent-3-ene system is known to thermally extrude germylene.<sup>26</sup> The germylene thus generated, however, might be expected to insert back into the starting material, since this is a known reaction for germacyclobutanes.<sup>17</sup> No insertion into the starting material was observed. In any case, the thermal stability of **57** was measured in the SFR system as shown in Figure 4. The graph shows the remaining starting material relative to an internal standard at the indicated temperature. Significant decomposition occurs in the temperature range of interest. Strangely, the presence of 2,3-dimethyl-1,3-butadiene appears to suppress decomposition at lower temperatures. Another point of interest is that some 1,1-dibutyl-1-germacyclopent-2-ene (**58**) was observed to be formed in these experiments. In the absence of a trap, larger amounts of **58** were observed which tended to remain constant, then decline above 450 °C. In the presence of 2,3-dimethyl-1,3-butadiene, the amount of the isomer **58** was much smaller and increased gradually up to 450 °C, after which it remained relatively constant. The presence of such an isomerization during the thermolysis of the parent 1,1-dimethyl-1-germacyclopent-3-ene system has not been previously described in the literature, although this isomerization has been reported for the silicon analog.<sup>27</sup> For the silicon analog, the apparent isomerization was proposed to arise from the homolytic cleavage of the C-C bond of the silacyclopropane ring of the vinylsilacyclopropane intermediate formed from the initial addition of silylene (produced from thermal extrusion of silacyclopent-3-ene) to 1,3-butadiene. This

cleavage produces a diradical intermediate, which upon ring closure yields the silacyclopent-2-ene isomer. A similar mechanism (shown in Scheme 26) may be operative in the production of the isomer **58**.

In the SFR system, the dibutylgermylene generated from **57** in the presence of 60 molar excess 2,3-dimethyl-1,3-butadiene could be trapped efficiently up to 450 °C, after which the amount of trapped germylene remained constant up to 475 °C and then declined.

Scheme 26. Proposed mechanism of isomerization of germacyclopent-3-ene **57** to germacyclopent-2-ene **58**.

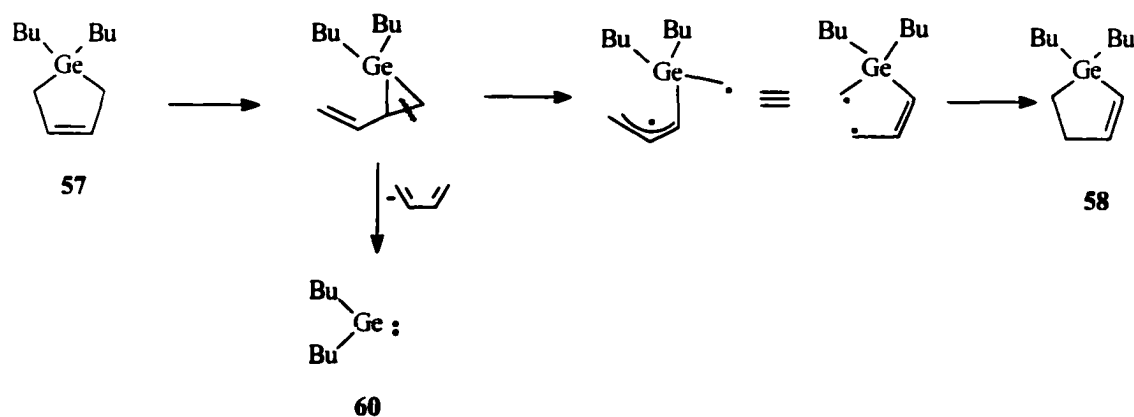

This is unusual, since the trapping of germylenes by 1,3-butadienes is usually very efficient. This poor trapping behavior led to our examination of the thermal behavior of di-*n*-alkylgermylenes. A review of the literature found few references to di-*n*-alkylgermylene formation in the gas phase, only a few studies that mainly dealt with matrix isolation and spectroscopic analysis of di-*n*-alkylgermylenes generated photochemically.<sup>28,29</sup> However, the silicon analogs had been studied and found to undergo intramolecular reactions in the gas phase that were much faster than even trapping with 1,3-butadienes.<sup>30</sup> If *n*-R<sub>2</sub>Ge: (where *n*-alkyl is ethyl or longer) behaves like the silicon analog, then it could undergo a very fast intramolecular β C-H insertion to form a germirane (Scheme 27).

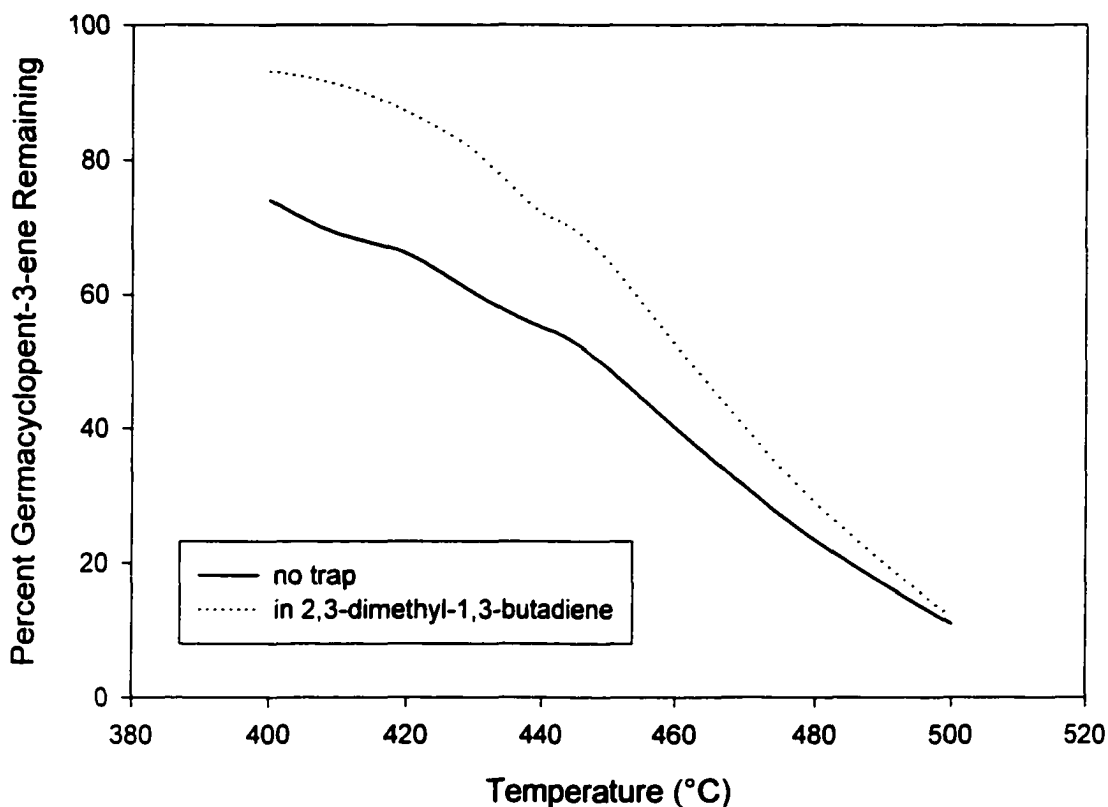
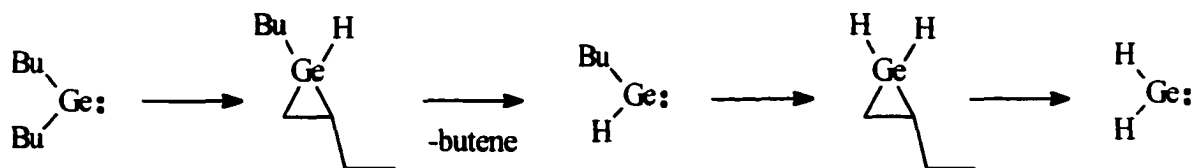

Figure 4. Decomposition of germacyclopent-3-ene **57** measured in an SFR system.

Scheme 27. Decomposition of dibutylgermylene.



The germirane decomposes quite readily<sup>31</sup> to an alkene and an *n*-alkylgermylene R(H)Ge:. The remaining *n*-alkyl group can be eliminated in the same manner leaving H<sub>2</sub>Ge:. The germylenes thus produced (R(H)Ge: and H<sub>2</sub>Ge:) could in theory also be trapped, but are likely to be unstable at the temperature of the thermolysis, with H<sub>2</sub>Ge: decomposing to H<sub>2</sub> and Ge. This process is fully considered and examined in Chapter 2 and is thought to be operative.

The kinetic analysis of **54** appeared to suffer from two fatal problems. The first was that one of the products, **57**, was unstable under the pyrolysis conditions. The second was that the most likely decomposition pathway of the material involved the extrusion of dibutylgermylene, which cannot be trapped or observed under the pyrolysis conditions due to intramolecular C-H insertion. Both of these problems would be solved if 1,1-dimethyl-2-methylenegermacyclobutane (**2**) could be isolated, since the germylene then generated (either from decomposition of **2** or **54**) could not decompose by the mechanism in Scheme 27 and thus should be “trapable”. With this in mind a molecule was designed that would generate “trapable” germylenes and also could provide enough steric bulk to hinder decomposition/polymerization. Thus, the synthesis of 1-methyl-2-methylene-1-phenylgermacyclobutane (**72**) was carried out according to Scheme 27. While **72** could be observed by GC-MS and even purified by column chromatography, unfortunately, its lifetime was measured in hours even when kept in a cold solution (see Figure 2 in the Appendix for the mass spectrum of **72**). This molecule therefore was not amenable to study.

Scheme 28. Synthesis of methylenegermacyclobutane **72**.

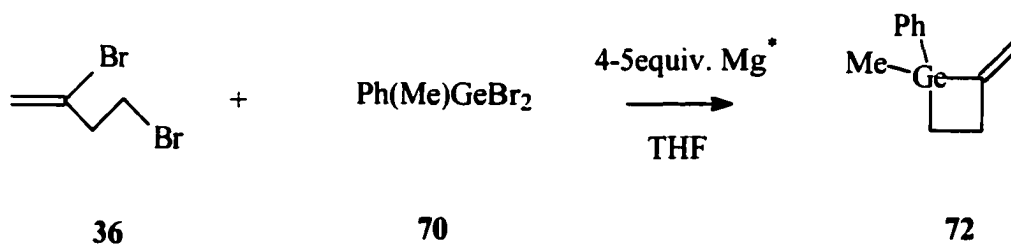

### Conclusion

Attempts to synthesize the 2-methylenegermacyclobutane system have been described. Several examples of this class of compound were synthesized using activated magnesium intermolecular coupling of 2,4-dibromo-1-butene (**36**) and various dialkyldihalogermans. The compounds 1,1-dimethyl-2-methylenegermacyclobutane (**2**), 1,1-diethyl-2-methylenegermacyclobutane (**53**), and 1-

methyl-2-methylene-1-phenylgermacyclobutane (**72**) were made and observed by GC-MS, but could not be isolated and were found to undergo decomposition to oils, possibly through ring opening polymerization. The novel 1,1-dibutyl-2-methylenegermacyclobutane (**54**) was isolated and found to have sufficient lifetime to allow the study of its thermal properties. The compound's decomposition pathways are complicated, but the data suggests that thermal isomerization, possibly through a 1,2-germyl shift to a carbene followed by C-H insertion, giving the ring expanded 1,1-dibutyl-1-germacyclopent-3-ene (**57**) and 1,1-dibutyl-1-germacyclopent-2-ene (**58**) is involved. Attempts at kinetic studies of this isomerization suggest that another process is involved also, possibly the extrusion of dibutylgermylene (**60**). However, due to the gas phase intramolecular C-H insertion of this species, its presence cannot be confirmed by trapping experiments.

### Experimental Section

A pulsed- stirred flow reactor (SFR) was used for the kinetic measurements, which is similar to the previously described design of Baldwin et. al.<sup>32</sup> The SFR reactor consisted of a quartz reactor with a volume of 4 cm<sup>3</sup>. The reactor was heated by an oven controlled by a Digi-Sense temperature controller. The reactor was connected to a Varian 6000 gas chromatograph (30 m DB-5 Megabore column, FID detector) by heated transfer line. Data was recorded on a Hewlett Packard 3390A integrator and a Magnum XT/Mark 2 microcomputer. Helium was used (60 mL/min flow rate) as the carrier gas.

Flow pyrolysis was carried out using a vertical 50 cm quartz tube (interior diameter of 15 mm) packed with quartz chips. The tube was heated by an oven controlled by a Digi-Sense temperature controller.

<sup>1</sup>H and <sup>13</sup>C NMR spectra were acquired on a Varian VXR-300 spectrometer. Chemical shifts are reported in parts per million with the indicated solvent as standard. Proton splitting is reported using standard abbreviations. Routine infrared spectra are reported in wave numbers (cm<sup>-1</sup>) obtained on a Bio-Rad Digilab FTS-7

spectrometer from a neat sample (except where noted). Other IR spectra were obtained on a Hewlett Packard GC-IR-MS (GC: HP 5890, IR: HP 5965A, MSD: HP 5970). UV/Vis spectra were obtained using a Hewlett Packard 8452A diode array UV/Vis spectrometer. Mass spectra are reported as  $m/z$  (relative intensity) and were obtained on the previously described GC-MS-IR or a Hewlett Packard GC-MS (GC: HP 5890 series II, MSD: HP 5972). Exact masses were acquired on a Kratos MS 50 mass spectrometer. Quantitative gas chromatography was performed on a Hewlett Packard 5890 series II GC equipped with a flame ionization detector. Except where indicated, a 30 m 0.25 mm i.d. capillary column with DB-5 stationary phase was utilized for all gas chromatography. The carrier gas used was helium.

THF and ether were distilled over sodium-benzophenone right before use. For rigorous drying, THF was subjected to a second distillation over lithium aluminum hydride before use. Other reagents were used as received (without further purification) from Aldrich, Fisher Chemical, or Gelest except where indicated.

**1-Tetrahydropyranyloxy-3-butyne (65).** This compound was made according to the literature procedure.<sup>33</sup> A solution of 3-butyne-1-ol (7 g, 7.56 mL, 100 mmol) and dihydropyran (13.4 g, 14.6 mL, 160 mmol) in ether (300 mL) was cooled to 0 °C. Next, *p*-toluenesulfonic acid (0.173 g, 1 mmol) was added and the reaction was stirred for 1.5 h. The reaction mixture was quenched with sat. sodium bicarbonate (200 mL) and extracted with ether (3 x 100mL). The organic portion was washed with sat. sodium bicarbonate (100 mL), water (100 mL), and sat. sodium chloride (100 mL) then dried over magnesium sulfate. The solvent was removed *in vacuo* giving **65** (14.65 g, 95 mmol, 95%) as a clear liquid without further purification (lit. b.p. 72-78 °C/20 torr<sup>33</sup>). <sup>1</sup>H NMR (CDCl<sub>3</sub>) δ 4.62 (t, *J* = 3.0 Hz, 1H), 3.86-3.76 (m, 2H, HC≡CCH<sub>2</sub>CH<sub>2</sub>O~), 3.57-3.50 (m, 2H), 2.5 (dt, *J* = 7.0, 2.7 Hz, 2H, HC≡CCH<sub>2</sub>CH<sub>2</sub>O~), 1.9 (t, *J* = 2.7 Hz, 1H, HC≡CCH<sub>2</sub>CH<sub>2</sub>O~), 1.80-1.48 (m, 6H); <sup>13</sup>C NMR (CDCl<sub>3</sub>) δ 98.8, 81.4, 69.3, 65.5, 62.2, 30.6, 25.5, 19.9, 19.4; IR (neat, cm<sup>-1</sup>) 3287, 2943, 2873, 2120, 1729, 1466, 1353, 1200, 1122, 1072, 1033, 981, 904, 869, 813, 653; GC-MS (EI):  $m/z$  153 ([M-H]<sup>+</sup>, 1), 98 (9), 95 (4), 86 (6), 85 (100), 83 (7), 79 (8), 67 (19), 57 (17), 56 (22), 55 (19), 54 (8), 53 (47), 52 (7), 51 (4)



**4-Bromo-3-tetrahydropyranyloxy-3-butyne (66).** This compound was made according to the literature procedure.<sup>34</sup> A flask was charged water (100 mL) and potassium hydroxide (25 g, 446 mmol). This solution was cooled to 0 °C and bromine (26.7 g, 8.6 mL, 166.9 mmol) was added slowly. Next **65** (15.4 g, 7.56 mL, 100 mmol) was added over 15 min after which the reaction mixture was allowed to warm to room temperature over 3.5 h. The reaction mixture was then extracted with ether (4 x 100 mL). The combined organic fraction was washed with water (100 mL) and then dried over magnesium sulfate. Solvent removal *in vacuo* gave **66** as a clear liquid (20 g, 86 mmol, 86%) without further purification. <sup>1</sup>H NMR (CDCl<sub>3</sub>) δ 4.6 (t, *J* = 3.1 Hz, 1H), 3.78 (dt, *J* = 9.7, 7.0 Hz, 2H, BrC≡CCH<sub>2</sub>CH<sub>2</sub>O~), 3.51 (dt, *J* = 9.8, 4 Hz, 2H), 2.48 (t, *J* = 7.0 Hz, 2H, BrC≡CCH<sub>2</sub>CH<sub>2</sub>O~), 1.72-1.15 (m, 6H); <sup>13</sup>C NMR (CDCl<sub>3</sub>) δ 98.8, 77.4, 65.3, 62.3, 39.1, 30.6, 25.5, 21.2, 19.4; IR (neat, cm<sup>-1</sup>) 2941, 2850, 2220, 1440, 1351, 1259, 1200, 1135, 1080, 1033, 982, 964, 905, 869, 813; GC-MS (EI): *m/z* 133 ([M-C<sub>5</sub>H<sub>9</sub>O<sub>2</sub>]<sup>+2</sup>, 9), 132 (8), 131 ([M-C<sub>5</sub>H<sub>9</sub>O<sub>2</sub>]<sup>+</sup>, 10), 130 (6), 113 (6), 101 (4), 95 (4), 86 (6), 85 (100), 67 (18), 57 (16), 56 (14), 55 (14), 53 (6), 52 (7), 51 (21), 50 (5).

**(Z)-4-Bromo-1-tetrahydropyranyloxy-3-butene (67).** A flask was charged with water (100 mL) and potassium hydroxide (56.1 g, 1 mol) and the solution cooled to -15 °C in an ice-salt bath. Azodicarbonamide (46.72 g, 400 mmol) was added slowly with mechanical stirring. The temperature was maintained below 10 °C during the addition, after which the reaction was stirred for 2 h with the temperature kept below 0 °C. The potassium azodicarboxylate thus formed as a yellow precipitate was then filtered and rinsed with cold methanol (2 x 50 mL). The azodicarboxylate was then placed in a flask fitted with a reflux condenser, addition funnel, and stirbar. The flask was then charged with methanol (200 mL) and 4-bromo-1-tetrahydropyranyloxy-3-butyne **66** (11.65 g, 50 mmol). The addition funnel was charged with acetic acid (19.5 mL). The solution was heated to 80 °C and the acetic acid added dropwise. Another portion of acetic acid (19.5 mL) was added slowly and the reaction refluxed for 2 h. Upon completion the reaction mixture was allowed to cool, then quenched in cold water (100 mL) and extracted with ether (4 x

75 mL). The combined organic portion was washed with water (100 mL), then dried over magnesium sulfate. After solvent removal *in vacuo*, purification by flash chromatography (hexane, silica gel) gave **67** (9.1 g, 38.5 mmol, 77%) as a clear liquid.  $^1\text{H}$  NMR ( $\text{CDCl}_3$ ) 6.24-6.18 (m, 2H,  $\text{Br}(\text{H})\text{C}=\text{C}(\text{H})\text{CH}_2\text{CH}_2\text{O}^-$ ), 4.5 (m, 1H), 3.84-3.75 (m, 2H,  $\text{Br}(\text{H})\text{C}=\text{C}(\text{H})\text{CH}_2\text{CH}_2\text{O}^-$ ), 2.50 (t,  $J = 7.0$  Hz, 2H,  $\text{Br}(\text{H})\text{C}=\text{C}(\text{H})\text{CH}_2\text{CH}_2\text{O}^-$ ), 1.8-1.5 (m, 6H);  $^{13}\text{C}$  NMR ( $\text{CDCl}_3$ )  $\delta$  131.8, 109.2, 98.8, 65.4, 62.3, 30.7, 30.6, 25.4, 19.5; IR (neat,  $\text{cm}^{-1}$ ) 3081, 2940, 2850, 1623, 1440, 1353, 1201, 1133, 1050, 1025, 983, 970, 869, 815; MS ( $\text{Cl}/\text{CH}_4$ ):  $m/z$  237 ( $[\text{M}+\text{H}]^{+2}$ , 19), 236 (4), 235 ( $[\text{M}+\text{H}]^+$ , 42), 232 (20), 205 (4), 203 (3), 179 (2), 177 (3), 165 (3), 163 (3), 155 (17), 137 (7), 136 (6), 135 (95), 134 (22), 133 (100), 132 (16), 128 (3), 127 (4), 125 (5), 115 (25), 107 (7), 102 (13), 101 (12), 100 (4), 97 (3); HRMS (EI)  $m/z$  calcd for  $\text{C}_9\text{H}_{15}\text{O}_2\text{Br}$  236.02556, found 236.02596.

**(Z)-4-bromo-3-butene-1-ol (68)**. A solution of (Z)-4-bromo-1-tetrahydropyranyloxy-3-butene **67** (9.1 g, 38.7 mmol) in 1:1 THF:MeOH (140 mL) was prepared. Next, *p*-toluenesulfonic acid (0.74 g, 3.9 mmol) was added with stirring at room temperature. After 8 h, the solvent was removed *in vacuo* and the product purified by distillation, giving **68** (4.1 g, 27 mmol, 70%) as a clear liquid (b.p. 42-44 °C/2 torr).  $^1\text{H}$  NMR ( $\text{CDCl}_3$ )  $\delta$  6.24 (dt,  $J = 7.2, 1.2$  Hz, 1H,  $\text{Br}(\text{H})\text{C}=\text{C}(\text{H})\text{CH}_2\text{CH}_2\text{OH}$ ), 6.17 (dt,  $J = 7.2, 6.9$  Hz, 1H,  $\text{Br}(\text{H})\text{C}=\text{C}(\text{H})\text{CH}_2\text{CH}_2\text{OH}$ ), 3.65 (t,  $J = 6.6$  Hz, 2H,  $\text{Br}(\text{H})\text{C}=\text{C}(\text{H})\text{CH}_2\text{CH}_2\text{OH}$ ), 2.97 (s, 1H,  $\text{Br}(\text{H})\text{C}=\text{C}(\text{H})\text{CH}_2\text{CH}_2\text{OH}$ ), 2.48 (m, 2H,  $\text{Br}(\text{H})\text{C}=\text{C}(\text{H})\text{CH}_2\text{CH}_2\text{OH}$ );  $^{13}\text{C}$  NMR ( $\text{CDCl}_3$ ) 131.3, 109.9, 33.25, 23.9; IR (neat,  $\text{cm}^{-1}$ ) 3333(br), 3083, 2947, 2883, 1623, 1419, 1290, 1050, 888, 678; GC-MS (EI):  $m/z$  152 ( $\text{M}^{+2}$ , 7), 150 ( $\text{M}^+$ , 7), 122 (80), 121 (19), 120 (84), 119 (18), 95 (8), 93 (8), 81 (7), 80 (4), 79 (6), 72 (5), 71 (100), 69 (4), 53 (13), 51 (8); HRMS (EI)  $m/z$  calcd for  $\text{C}_4\text{H}_7\text{OBr}$  169.96803, found 169.96835.

**(Z)-1,4-Dibromo-1-butene (69)**. A flask was fitted with stirbar, drying tube and flushed with argon. The flask was then charged with (Z)-4-bromo-3-butene-1-ol **68** (3.5 g, 23.3 mmol) and cooled to -15 °C in an ice-salt bath. Argon flow was then stopped and phosphorous tribromide (2.14 g, 0.75 mL, 7.88 mmol) was added dropwise by syringe with stirring. The temperature was kept below 0 °C. After

completion of addition the reaction was allowed to stir for 30 min (at less than 0 °C). The reaction mixture was then allowed to warm to room temperature and stir overnight. The reaction mixture was quenched with cold water (100 mL), and extracted with ether (2 x 75 mL). The combined organic portion was washed with sat. sodium chloride (75 mL) and water (75 mL) then dried over magnesium sulfate. After solvent removal *in vacuo*, purification by vacuum distillation gave **69** (3.6 g, 17 mmol, 73%) as a clear liquid (b.p. 74-76 °C/15 torr). <sup>1</sup>H NMR (CDCl<sub>3</sub>) δ 6.33 (dt, *J* = 7.2, 1.2 Hz, 1H, Br(H)C=C(H)CH<sub>2</sub>CH<sub>2</sub>Br), 6.20 (dt, *J* = 7.2, 6.9 Hz, 1H, Br(H)C=C(H)CH<sub>2</sub>CH<sub>2</sub>Br), 3.43 (t, *J* = 6.9 Hz, 2H, Br(H)C=C(H)CH<sub>2</sub>CH<sub>2</sub>Br), 2.78 (dt, *J* = 6.9, 6.6 Hz, 2H, Br(H)C=C(H)CH<sub>2</sub>CH<sub>2</sub>Br); <sup>13</sup>C NMR (CDCl<sub>3</sub>) 131.6, 110.5, 43.8, 33.8; IR (neat, cm<sup>-1</sup>) 3080, 2962, 2903, 1624, 1440, 1265, 1053, 974, 785, 664; GC-MS (EI): *m/z* 216 (M<sup>+</sup>, 10), 214 (M<sup>+</sup>, 21), 212 (M<sup>+</sup>, 10), 136 (4), 135 (95), 134 (12), 133 (100), 121 (20), 119 (22), 108 (4), 107 (4), 106 (5), 105 (4), 95 (6), 93 (8), 82 (4), 81 (9), 80 (4), 79 (9), 54 (6), 53 (76), 52 (7), 51 (16).

**1-Methyl-1-phenyl-1-germacyclopent-2-ene (71).** A flask fitted with reflux condenser, addition funnel and flushed with argon was charged with dry THF (50 mL), anhydrous magnesium chloride (4.08 g, 48 mmol), and potassium metal (1.71 g, 21.8 mmol). The reaction mixture was refluxed until it turned gray and then refluxed a further 2 h. The reaction mixture was then cooled to room temperature. A solution of methylphenylgermanium dibromide (1.78 g, 5.46 mmol) and (*Z*)-1,4-dibromo-3-butene (1.16 g, 5.46 mmol) in THF (10 mL) was prepared and added dropwise by an addition funnel. Upon completion, the reaction was allowed to stir for 1 h, then quenched in cold HCl (2 M, 150 mL) and extracted with ether (2 x 100 mL). The combined organic fraction was washed with sat. sodium bicarbonate (100 mL), water (100 mL), and sat. sodium chloride (100 mL) then dried over magnesium sulfate. After solvent removal *in vacuo*, purification was accomplished by flash chromatography (hexane, silica gel) and gave **71** (0.180 g, 0.82 mmol, 15%) as a clear liquid. <sup>1</sup>H NMR (CDCl<sub>3</sub>) δ 7.55-7.51 (m, 2H, ArH), 7.43-7.40 (m, 3H, ArH), 6.97-6.93 (m, 1H, ~Ge-(H)C=C(H)~), 6.37-6.34 (m, 1H, ~Ge-(H)C=C(H)~), 2.75-2.69 (m, 2H, ~Ge-CH<sub>2</sub>CH<sub>2</sub>~), 1.25-1.06 (m, 2H, ~Ge-CH<sub>2</sub>CH<sub>2</sub>~), 0.68 (s, 3H, ~GeCH<sub>3</sub>);

$^{13}\text{C}$  NMR ( $\text{CDCl}_3$ ) 150.4, 140.9, 133.5, 128.7, 128.6, 128.2, 33.1, 9.6, -3.6; IR (neat,  $\text{cm}^{-1}$ ) 3066, 2980, 2904, 2829, 1570, 1483, 1431, 1308, 1236, 1092, 987, 898, 794, 732, 698, 637; GC-MS (EI):  $m/z$  222 (3), 221 (2), 220 ( $M^+$ , 16), 219 (5), 218 (11), 216 (9), 207 (21), 206 (13), 205 (100), 204 (33), 203 (77), 201 (57), 153 (12), 152 (4), 151 (56), 150 (16), 149 (44), 148 (4), 147 (34), 125 (9), 123 (8), 115 (4), 101 (6), 99 (14), 97 (10), 95 (6), 91 (9), 89 (14), 88 (4), 87 (11), 85 (7), 77 (4), 74 (4), 50 (8); HRMS (EI)  $m/z$  calcd for  $\text{C}_{11}\text{H}_{14}\text{Ge}$  220.03090, found 220.031208.

**1,1-Dibutyl-1-germacyclopent-2-ene (58).** A 100 mL flask was fitted with reflux condenser, addition funnel, and flushed with argon. The flask was then charged with dry THF (50 mL), anhydrous magnesium chloride (4.0 g, 48 mmol), and potassium metal (1.171 g, 48 mmol) then heated to reflux for 3 h after the solution's initial change to a gray color. Next the reaction mixture was cooled to room temperature and a solution of dibutyldichlorogermane (1.4 g, 5.46 mmol) and (*Z*)-1,4-dibromo-1-butene **69** (1.16 g, 5.46 mmol) in THF (THF) was added dropwise by an addition funnel over 30 min. The reaction mixture was allowed to stir for 1 h at room temperature before quenching in cold HCl (150 mL) followed by extraction with ether (2 x 100 mL). The combined organic portion was washed with sat. sodium bicarbonate (100 mL), water (100 mL), and sat. sodium chloride (100 mL) then dried over magnesium sulfate. After solvent removal *in vacuo*, purification by flash chromatography (hexane, silica gel) gave **58** (0.390 g, 1.6 mmol, 29%) as a clear liquid.  $^1\text{H}$  NMR ( $\text{CDCl}_3$ )  $\delta$  6.73 (dt,  $J = 9.3, 2.7$  Hz, 1H,  $\sim\text{Ge}-(\text{H})\text{C}=\text{C}(\text{H})\sim$ ), 6.15 (dt,  $J = 9.3, 2.4$  Hz, 1H,  $\sim\text{Ge}-(\text{H})\text{C}=\text{C}(\text{H})\sim$ ), 2.52 (m, 2H,  $\sim\text{GeCH}_2\text{CH}_2\sim$ ), 1.35-1.32 (m, 8H), 0.92-0.84 (m, 12H);  $^{13}\text{C}$  NMR ( $\text{CDCl}_3$ ) 149.0, 128.9, 33.1, 27.9, 26.2, 14.9, 13.9, 6.6; IR (neat,  $\text{cm}^{-1}$ ) 3028, 2957, 2924, 2855, 1570, 1463, 1376, 1080, 980, 876, 760; GC-MS (EI):  $m/z$  215 (2), 214 (1), 212 (3), 200 (1), 187 (14), 186 (10), 185 (100), 183 (60), 182 (17), 181 (55), 131 (20), 129 (89), 127 (68), 125 (46), 103 (6), 101 (15), 99 (12), 89 (7), 87 (5); HRMS (EI)  $m/z$  calcd for  $\text{C}_{12}\text{H}_{24}\text{Ge}$  242.109186, found 242.109587.

**Methylphenyldibromogermane (70).** This compound was made according to a modification of the literature procedure.<sup>35</sup> A solution of methyltriphenylgermane

(10 g, 21.25 mmol) in bromoethane (125 mL) was prepared and cooled to 0 °C. A solution of bromine (11.6 g, 3.75 mL, 72.8 mmol) in bromoethane (10 mL) was added dropwise over 2 h by an addition funnel. Upon completion the reaction mixture was warmed to room temperature and stirred in the dark under argon for 11 days. After solvent removal by distillation at atmospheric pressure, purification by vacuum distillation provided **70** (8.6 g, 26.4 mmol, 84%) as a clear liquid (b.p. 96-98 °C/1.5 torr, lit. b.p. 139-140 °C/15 torr<sup>36</sup>). <sup>1</sup>H NMR (CDCl<sub>3</sub>) δ 7.38 (m, 2H, ArH), 6.98 (m, 3H, ArH), 1.00 (s, 3H, GeCH<sub>3</sub>); <sup>13</sup>C NMR (CDCl<sub>3</sub>) 136.9, 131.6, 131.2, 128.6, 10.7; GC-MS (EI): *m/z* 328 (M<sup>+4</sup>, 3), 326 (M<sup>+2</sup>, 7), 324 (M<sup>+</sup>, 8), 322 (5), 313 (6), 311 (14), 309 (14), 307 (9), 249 (16), 247 (71), 246 (27), 245 (100), 243 (77), 241 (34), 232 (4), 230 (4), 157 (7), 155 (36), 154 (11), 153 (57), 151 (60), 149 (34), 147 (13), 125 (5), 123 (7), 121 (5), 99 (9), 97 (7), 95 (6), 91 (10), 89 (9), 88 (4), 87 (7), 85 (5), 77 (50), 75 (6), 74 (11), 73 (4), 65 (5), 51 (44), 50 (21).

**Tetraethylgermane (55).** This compound was made according to the literature procedure.<sup>37</sup> A flask fitted with a mechanical stirrer and addition funnel was charged with ethylmagnesium chloride (186 mL, 372 mmol, 2.0 M in THF), dry THF (100 mL), and cooled to -78 °C. To this stirring solution was added germanium tetrachloride (20 g, 10.6 mL, 93 mmol) by an addition funnel. Upon completion of the addition, the reaction mixture was allowed to warm to room temperature and stir for 3 h. The reaction mixture was then quenched in cold HCl (2 M, 200 mL) and extracted with ether (2 x 150 mL). The combined organic fraction was washed with sat. sodium bicarbonate (150 mL), water (150 mL), and sat. sodium chloride (150 mL) then dried over magnesium sulfate. After solvent removal *in vacuo*, the product was purified by vacuum distillation giving **55** (17.9 g, 88.4 mmol, 95%) as a clear liquid (b.p. 46-48 °C/12 torr, lit. b.p. 162.5-163 °C/760 torr<sup>38</sup>). <sup>1</sup>H NMR (CDCl<sub>3</sub>) δ 1.02 (t, *J* = 7.5 Hz, 12H, Ge(CH<sub>2</sub>CH<sub>3</sub>)<sub>4</sub>), 0.706 (q, *J* = 7.5 Hz, 8H, Ge(CH<sub>2</sub>CH<sub>3</sub>)<sub>4</sub>); <sup>13</sup>C NMR (CDCl<sub>3</sub>) δ 9.2, 3.7; IR (neat, cm<sup>-1</sup>) 2949, 2907, 2825, 1461, 1426, 1376, 1235, 1019, 1007, 969, 704, 573; GC-MS (EI): *m/z* 190 (M<sup>+</sup>, 2), 189 (1), 188 (1), 163 (14), 162 (5), 161 (67), 160 (19), 159 (51), 157 (38), 135 (21), 134 (6), 133 (100), 132 (29), 131 (77), 130 (5), 129 (58), 107 (10), 106 (2), 105 (51), 104 (15), 103 (57), 102

(10), 101 (45), 100 (4), 99 (16), 97 (3), 91 (2), 89 (4), 88 (2), 87 (4), 86 (2), 85 (2), 79 (2), 77 (12), 76 (4), 75 (22), 74 (12), 73 (18), 72 (7), 71 (9), 70 (5).

**Tetrabutylgermane (56).** This compound was made according to the literature procedure.<sup>39</sup> A flask fitted with a mechanical stirred and addition funnel was charged with *n*-butylmagnesium chloride (186 mL, 372 mmol, 2.0 M in THF), dry THF (100 mL) and cooled to  $-78\text{ }^{\circ}\text{C}$ . To this stirring solution was added germanium tetrachloride (20 g, 10.6 mL, 93 mmol) by an addition funnel. Upon completion of the addition, the reaction mixture was allowed to warm to room temperature and stir for 3 h. The reaction mixture was then quenched in cold HCl (2 M, 200 mL) and extracted with ether (2 x 150 mL). The combined organic fraction was washed with sat. sodium bicarbonate (150 mL), water (150 mL), and sat. sodium chloride (150 mL) then dried over magnesium sulfate. After solvent removal *in vacuo*, the product was purified by vacuum distillation giving **56** (26.5 g, 87.7 mmol, 94%) as a clear liquid (b.p.  $118\text{-}120\text{ }^{\circ}\text{C}/2\text{ torr}$ , lit. b.p.  $278\text{ }^{\circ}\text{C}/760\text{ torr}^{40}$ ).  $^1\text{H}$  NMR ( $\text{CDCl}_3$ )  $\delta$  1.35-1.28 (m, 16H), 0.91-0.87 (m, 12H), 0.72-0.66 (m, 8H);  $^{13}\text{C}$  NMR ( $\text{CDCl}_3$ )  $\delta$  27.6, 26.7, 13.9, 12.5; IR (neat,  $\text{cm}^{-1}$ ) 2956, 2922, 2855, 1564, 1420. 1376, 1173, 1082, 1002, 963, 884, 694, 643; GC-MS (EI): *m/z* 245 ( $[\text{M-Bu}]^+$ , 3), 244 (5), 243 (10), 241 (9), 191 (12), 190 (6), 189 (52), 188 (17), 187 (40), 185 (3), 135 (12), 134 (5), 133 (73), 132 (23), 131 (57), 130 (11), 129 (47), 128 (5), 127 (5), 126 (4), 105 (19), 104 (7), 103 (31), 102 (10), 101 (32), 100 (6), 99 (17), 93 (5), 91 (37), 90 (9), 89 (52), 88 (10), 87 (38), 85 (21), 77 (11), 76 (6), 75 (21), 74 (17), 73 (18), 72 (13), 71 (9), 70 (10), 58 (5), 57 (67), 56 (15), 55 (100), 54 (4), 53 (12), 51 (5).

**Diethyldichlorogermane (51).** This compound was made by a modification of a literature procedure.<sup>24</sup> A flask fitted with reflux condenser and charged with tetraethylgermane (4.6 g, 24.4 mmol) and 0.2 equivalents of aluminum trichloride (0.66 g, 4.9 mmol). The reaction mixture was heated to  $85\text{ }^{\circ}\text{C}$ , then 1.95 equivalents of 2-chloropropane (, 3.6 g, 4.2 mL, 46.25 mmol) were added slowly by syringe. Upon completion, the reaction mixture was heated at  $85\text{ }^{\circ}\text{C}$  for an addition 1.5 h. Isolation by vacuum distillation gave **51** (5.56 g, 20.7 mmol, 85%) as a clear liquid (b.p.  $53\text{-}55\text{ }^{\circ}\text{C}/12\text{ torr}$ , lit. b.p.  $175\text{ }^{\circ}\text{C}/760\text{ torr}^{41}$ ).  $^1\text{H}$  NMR ( $\text{CDCl}_3$ )  $\delta$  1.58 (q,  $J = 7.8$

Hz, 4H,  $\sim\text{Ge}(\text{CH}_2\text{CH}_3)_2$ ), 1.26 (t,  $J = 7.8$  Hz, 6H,  $\sim\text{Ge}(\text{CH}_2\text{CH}_3)_2$ );  $^{13}\text{C}$  NMR ( $\text{CDCl}_3$ )  $\delta$  18.4, 7.6; IR (neat,  $\text{cm}^{-1}$ ) 2968, 2912, 2879, 1459, 1425, 1383, 1229, 1020, 974, 709, 606, 563; GC-MS (EI):  $m/z$  204 ( $\text{M}^{+2}$ , 5), 202 ( $\text{M}^+$ , 8), 201 (2), 200 (6), 198 (3), 177 (15), 175 (59), 174 (12), 173 (100), 172 (18), 171 (74), 169 (42), 168 (5), 167 (11), 166 (10), 165 (9), 164 (6), 163 (5), 162 (4), 147 (7), 146 (4), 145 (12), 144 (7), 143 (10), 142 (5), 141 (7), 140 (7), 139 (9), 138 (14), 137 (14), 136 (11), 135 (8), 134 (6), 133 (4), 132 (1), 113 (3), 111 (28), 110 (4), 109 (45), 108 (9), 107 (34), 105 (20), 103 (3), 102 (1), 101 (3), 100 (1), 99 (4), 98 (1), 97 (2), 75 (6), 74 (6), 73 (5), 72 (3), 71 (3), 70 (3).

**Dibutyldichlorogermane (52).** This compound was made by a modification of a literature procedure.<sup>24</sup> Method 1: A flask was fitted with a mechanical stirrer and addition funnel, then flushed with argon. The flask was then charged with dry THF (300 mL) and germanium tetrachloride (42.8 g, 22.78 mL, 200 mmol). The reaction was cooled to  $-78$  °C and butylmagnesium chloride (200 mL, 400 mmol, 2.0 M in THF) was added slowly over 3 h by an addition funnel. The reaction mixture was then warmed to room temperature and stirred overnight. Next hexane (100 mL) was added and magnesium chloride precipitate was filtered out under argon. The solvent was then mostly removed by rotary evaporation (the apparatus was equipped with a drying tube) and another portion of hexane (200 mL) was added and the solution filtered again. This process was repeated a third time. This crude product consisted of a mixture of tributylchlorogermane, dibutyldichlorogermane, tetrabutylgermane, and butyltrichlorogermane in a 1:1:1:0.1 ratio. After solvent removal *in vacuo*, purification was accomplished by vacuum distillation using a 50 cm jacketed column packed with glass helices. This gave **52** (8 g, 31 mmol, 16%) as a clear liquid (b.p. 81-83 °C/2 torr, lit. b.p. 242 °C/760 torr<sup>42</sup>).

Method 2: A flask fitted with reflux condenser was charged with tetrabutylgermane (7.4 g, 24.4 mmol) and 0.2 equivalents of aluminum trichloride (0.66 g, 4.9 mmol). The reaction mixture was heated to 85 °C, then 1.95 equivalents of 2-chloropropane (3.6 g, 4.2 mL, 46.25 mmol) were added slowly by syringe. Upon completion, the reaction was heated at 85 °C for an additional 1.5 h. Isolation

by vacuum distillation gave **52** (5.67 g, 22 mmol, 90%) as a clear liquid (b.p. 83-85 °C/2 torr, lit. b.p. 242 °C/760 torr<sup>42</sup>). <sup>1</sup>H NMR (CDCl<sub>3</sub>) δ 1.60 (m, 8H), 1.43 (m, 4H), 0.94 (t, *J* = 7.2 Hz, 6H); <sup>13</sup>C NMR (CDCl<sub>3</sub>) δ 26.1, 25.6, 25.2, 13.8; IR (neat, cm<sup>-1</sup>) 2960, 2929, 2872, 1464, 1380, 1295, 1184, 1086, 1002, 963, 886, 694; GC-MS (EI): *m/z* 224 (3), 223 (2), 222 (7), 221 (3), 220 (5), 218 (3), 205 (3), 205 (3), 203 (11), 201 (18), 200 (3), 199 (13), 197 (7), 170 (2), 168 (9), 167 (5), 166 (19), 165 (9), 164 (15), 163 (4), 162 (9), 145 (2), 111 (5), 110 (1), 109 (11), 108 (2), 107 (8), 105(5), 58 (5), 57 (100), 56 (15), 55 (6), 53 (2).

**2,4-Dibromo-1-butene (36).** Method 1: The compound was made according to the literature procedure.<sup>2</sup> A 100 mL round bottom flask equipped with addition funnel and magnetic stirrer was charged with 3-bromo-3-butene-1-ol **44** (20 g, 132 mmol) and cooled to -10 °C in an ice-salt bath. Phosphorous tribromide (11.9 g, 4.18 mL, 44 mmol) was added dropwise by an addition funnel, the temperature being maintained at -10 °C or below. After the addition was complete, the reaction mixture was warmed to room temperature and stirred overnight. The reaction mixture was then distilled into water (10 mL). The product was washed twice with concentrated sulfuric acid (10 mL) and dried over potassium carbonate. After solvent removal *in vacuo*, vacuum distillation gave **36** (18.9 g, 88 mmol, 67%) as a clear liquid (b.p. 72-73 °C/18 torr).

Method 2. A 100 mL round bottom flask equipped with addition funnel, magnetic stirrer, drying tube and charged with 3-butyne-1-ol (14 g, 15.2 mL, 200 mmol). The reaction mixture was cooled to -10 °C in an ice-salt bath. Phosphorous tribromide (18.0 g, 5.7 mL, 66.6 mmol) was added slowly by means of an addition funnel, with the temperature maintained at -10 °C or below. The reaction mixture was warmed to room temperature and stirred overnight. After solvent removal *in vacuo*, vacuum distillation through a 15 cm Vigreux column gave **36** (11.98 g, 56 mmol, 28%) as a clear liquid (b.p. 68-70 °C/15 torr, lit. b.p. 72-73 °C/18 torr<sup>2</sup>). <sup>1</sup>H NMR (CDCl<sub>3</sub>) δ 5.71 (d, *J* = 1.8 Hz, 1H, H(*trans*-H)C=C(Br)CH<sub>2</sub>CH<sub>2</sub>Br), 5.56 (d, *J* = 1.8 Hz, 1H, *cis*-H(H)C=C(Br)CH<sub>2</sub>CH<sub>2</sub>Br), 3.55 (t, *J* = 6.9 Hz, 2H, H<sub>2</sub>C=C(Br)CH<sub>2</sub>CH<sub>2</sub>Br), 2.93 (t, *J* = 6.9 Hz, 2H, H<sub>2</sub>C=C(Br)CH<sub>2</sub>CH<sub>2</sub>Br); <sup>13</sup>C NMR



(CDCl<sub>3</sub>)  $\delta$  130.1, 119.7, 44.2, 29.8; IR (neat, cm<sup>-1</sup>) 3110, 2980, 1432, 1315, 1277, 1177, 1102, 895, 819; GC-MS (EI): *m/z* 216 (M<sup>+4</sup>, 9), 214 (M<sup>+2</sup>, 18), 212 (M<sup>+</sup>, 10), 136 (4), 135 (82), 133 (86), 107 (6), 105 (4), 95 (6), 93 (7), 81 (8), 80 (3), 79 (7), 54 (8), 53 (100), 52 (6), 51 (16).

**3-Bromo-3-butene-1-ol (44).** The compound was made according to the literature procedure<sup>24,43</sup> A 50 mL flask was fitted with an addition funnel, stirbar, and connected to a 500 mL flask containing a solution of tetraethylammonium bromide (63.0 g, 300 mmol) in methylene chloride (300 mL) at 0 °C by a transfer line. The 50 mL flask was charged with water (5.94 mL, 330 mmol). Phosphorous tribromide (10.46 mL, 110 mmol) was added dropwise by an addition funnel to generate HBr, which was bubbled through the methylene chloride solution. After completion, the methylene chloride solution had absorbed the HBr (18.7 g, 231 mmol). Next, 3-butyn-1-ol (7.7 g, 8.3 mL, 110 mmol) was added to the solution. The flask was sealed with a septum and heated to 40 °C for 5 h. The reaction mixture was then cooled to 0 °C and ether (600 mL) was added, causing the ammonium salts to precipitate. The precipitate was then removed by filtration. The resulting solution, after solvent removal *in vacuo* and vacuum distillation, provided **44** (12.46 g, 82.5 mmol, 75%) as a clear liquid (b.p. 74-76 °C/15 torr, lit. b.p. 69-70 °C/11 torr<sup>2</sup>). <sup>1</sup>H NMR (CDCl<sub>3</sub>)  $\delta$  5.68 (m, 1H, H(*trans*-H)C=C(Br)CH<sub>2</sub>CH<sub>2</sub>OH), 5.52 (d, *J* = 1.8 Hz, 1H, *cis*-H(H)C=C(Br)CH<sub>2</sub>CH<sub>2</sub>OH), 3.78 (t, *J* = 6.0 Hz, 2H, H<sub>2</sub>C=C(Br)CH<sub>2</sub>CH<sub>2</sub>OH), 2.64 (td, *J* = 6.0, 0.9 Hz, 2H, H<sub>2</sub>C=C(Br)CH<sub>2</sub>CH<sub>2</sub>OH); <sup>13</sup>C NMR (CDCl<sub>3</sub>)  $\delta$  130.5, 119.3, 60.1, 44.4; IR (GC-MS-IR, cm<sup>-1</sup>) 3662, 2948, 1626, 1387, 1125, 1048, 891; GC-MS (EI): *m/z* 152 (M<sup>+2</sup>, 17), 150 (M<sup>+</sup>, 17), 123 (5), 122 (94), 121 (6), 120 (100), 81 (4), 80 (2), 79 (4), 53 (25), 51 (8).

**1,1-Dibutyl-2-methylenegermacyclobutane (54).** A 100 mL flask was fitted with addition funnel, stirbar, and reflux condenser, and then flushed with argon. The flask was charged with dry THF (50 mL), anhydrous magnesium chloride (3.99 g, 41.36 mmol), and potassium metal (1.46 g, 37.6 mmol). The reaction mixture was heated to reflux until the formation of activated magnesium was apparent, then heated for an additional 2 h. Next, while still refluxing, a solution of 2,4-dibromo-1-

butene **36** (2.0 g, 9.4 mmol) and dibutyldichlorogermane **52** (2.4 g, 2 mL, 9.4 mmol) in THF (10 mL) was added slowly by an addition funnel. The reaction mixture was refluxed for 15 min following the completion of addition, then cooled to room temperature. The reaction mixture was quenched with sat. ammonium chloride (150 mL) and extracted with ether (2 x 75 mL). The combined organic fractions were washed with sat. sodium bicarbonate (100 mL), water (100 mL), and sat. sodium chloride (100 mL) then dried over magnesium sulfate. After careful solvent removal *in vacuo*, purification by flash chromatography (hexane, silica gel) gave **54** (0.8 g 3.3 mmol, 35%) as a clear liquid.  $^1\text{H}$  NMR ( $\text{CDCl}_3$ )  $\delta$  5.44 (dt,  $J = 2.2, 1.5$  Hz, 1H, ( $\sim\text{Ge}$ )( $\sim\text{CH}_2$ )C=C(*cis*-H)(H)), 5.06 (dt,  $J = 2.8, 1.5$  Hz, 1H, ( $\sim\text{Ge}$ )( $\sim\text{CH}_2$ )C=C(H)(*trans*-H), 2.87 (tt,  $J = 8.0, 2.5$  Hz, 2H,  $\sim\text{Ge}-\text{CH}_2-\text{CH}_2\sim$ ), 1.5 (m, 2H), 1.33 (m, 8H), 1.06 (t,  $J = 7.8$  Hz, 4H), 0.88 (t,  $J = 7.5$  Hz, 6H);  $^{13}\text{C}$  NMR ( $\text{CDCl}_3$ )  $\delta$  162.5, 117.2, 36.1, 27.8, 26.6, 16.4, 13.8, 11.7; GC-MS (EI):  $m/z$  242 ( $\text{M}^+$ , 1), 216 (4), 215 (3), 214 (21), 213 (7), 212 (16), 210 (11), 188 (8), 187 (12), 186 (18), 185 (38), 184 (21), 183 (27), 182 (8), 181 (18), 159 (6), 158 (6), 157 (19), 156 (8), 155 (13), 154 (3), 153 (10), 145 (4), 144 (5), 143 (9), 142 (5), 141 (6), 134 (5), 133 (7), 132 (32), 131 (41), 130 (62), 129 (100), 128 (62), 127 (70), 126 (25), 125 (44), 117 (4), 116 (5), 115 (11), 114 (5), 113 (9), 111 (7), 105 (5), 104 (5), 103 (33), 102 (16), 101 (44), 100 (20), 99 (36), 98 (10), 97 (20), 91 (10), 89 (36), 88 (11), 87 (28), 85 (19), 77 (4), 76 (4), 75 (12), 74 (18), 73 (12), 72 (12), 71 (6), 70 (9), 57 (4), 55 (9).

**1-Methyl-2-methylene-1-phenylgermacyclobutane (72)**. A 100 mL flask was fitted with an addition funnel, reflux condenser and stirbar. The apparatus was flushed with argon and charged with dry THF (50 mL), anhydrous magnesium chloride (4.0896 g, 48 mmol), and potassium metal (1.71 g, 43.68 mmol). The solution was heated to reflux for 2.5 h, and then allowed to cool to room temperature. The addition funnel was charged with dry THF (10 mL), 2,4-dibromo-1-butene **36** (1.16 g, 5.46 mmol), and methylphenyldibromogermane **70** (1.78 g, 5.46 mmol). This solution was added dropwise at room temperature, then the reaction was stirred for 1 h. The reaction mixture was then quenched with cold dilute HCl (150 mL) and extracted with ether (2 x 75 mL). The combined organic fraction was

washed with sat. sodium bicarbonate (100 mL), water (100 mL), and sat. sodium chloride (100 mL), then dried over magnesium sulfate. Careful solvent removal *in vacuo*, gave a crude liquid that was purified by flash chromatography (hexane, silica gel). The resulting material, **72** (48 mg, 0.22 mmol, 4%) was analyzed by GC-MS, but quickly decomposed to an oily material before characterization could be completed. GC-MS (EI):  $m/z$  220 ( $M^+$ , 1), 219 (1), 218 (1), 207 (13), 206 (8), 205 (64), 204 (20), 203 (52), 202 (7), 201 (40), 179 (4), 178 (3), 177 (11), 176 (5), 175 (10), 173 (6), 167 (7), 166 (17), 165 (22), 164 (15), 163 (16), 162 (10), 161 (9), 153 (20), 152 (8), 151 (100), 150 (30), 149 (80), 147 (60), 131 (7), 129 (4), 127 (4), 125 (14), 124 (4), 123 (11), 121 (8), 101 (7), 99 (21), 98 (6), 97 (17), 95 (11), 91 (19), 89 (21), 88 (7), 87 (17), 85 (12), 77 (5), 74 (6), 72 (5), 53 (4), 51 (11).

**1,1-Dimethyl-2-methylenegermacylobutane (2)**. A 100 mL flask with addition funnel, stirbar, and reflux condenser was flushed with argon, and then charged with dry THF (50 mL), anhydrous magnesium chloride (3.9 g, 41.46 mmol), and potassium metal (1.46 g, 37.6 mmol). The reaction was heated to reflux for 2 h. The addition funnel was charged with 2,4-dibromo-1-butene (2.0 g, 9.4 mmol), of dimethyldichlorogermane (1.6 g, 9.4 mmol) and dry THF (10 mL). This solution was added dropwise while refluxing. Upon completion of the addition, the reaction mixture was refluxed for another 20 min, then cooled to room temperature and quenched with sat. ammonium chloride (150 mL) and extracted with pentane (2 x 75 mL). The organic portion was washed with sat. sodium bicarbonate (100 mL), water (100 mL), and sat. sodium chloride (100 mL), then dried over magnesium sulfate. The product was observed by GC-MS, however all attempts at isolation failed, resulting in a viscous oil, perhaps due to ring opening polymerization. GC-MS (EI):  $m/z$  158 ( $M^+$ , 17), 157 (6), 156 (11), 154 (7), 143 (46), 142 (12), 141 (33), 139 (25), 130 (12), 129 (8), 128 (10), 127 (4), 126 (6), 118 (12), 117 (8), 116 (10), 115 (17), 114 (8), 112 (16), 111 (10), 106 (11), 105 (11), 104 (41), 103 (23), 102 (37), 101 (18), 100 (36), 99 (22), 98 (6), 97 (16), 95 (8), 91 (20), 90 (5), 89 (100), 88 (31), 87 (70), 86 (13), 85 (53), 84 (6), 77 (7), 75 (18), 74 (20), 73 (18), 72 (16), 71 (15), 70 (11), 68 (6), 60 (4), 55 (7), 54 (4), 53 (9), 52 (5), 51 (10).

**1,1-Diethyl-2-methylenegermacyclobutane (53).** A 100 mL flask with addition funnel, stirbar, and reflux condenser was flushed with argon, and then charged with dry THF (50 mL), anhydrous magnesium chloride (1.97 g, 20.68 mmol), and potassium metal (1.46 g, 37.6 mmol). The reaction mixture was heated to reflux for 2 h. The addition funnel was charged with 2,4-dibromo-1-butene (2.0 g, 9.4 mmol), diethyldichlorogermane (1.86 g, 9.4 mmol) and dry THF (10 mL). This solution was added dropwise while refluxing. Upon completion of the addition, the reaction mixture was refluxed for another 20 min, then cooled to room temperature and quenched with sat. ammonium chloride (150 mL) and extracted with pentane (2 x 75 mL). The organic portion was washed with sat. sodium bicarbonate (100 mL), water (100 mL), and sat. sodium chloride (100 mL), then dried over magnesium sulfate. The product was observed by GC-MS, however all attempts at isolation failed, resulting in a viscous oil possibly due to ring opening polymerization. GC-MS (EI): *m/z* 188 (5), 187 (2), 186 ( $M^+$ , 6), 184 (16), 182 (12), 160 (16), 159 (18), 158 (76), 157 (78), 156 (69), 155 (47), 154 (42), 153 (33), 134 (8), 132 (39), 131 (28), 130 (34), 129 (85), 128 (44), 127 (65), 126 (6), 125 (48), 118 (9), 117 (4), 116 (8), 115 (9), 114 (8), 113 (10), 111 (7), 106 (4), 105 (17), 104 (22), 103 (82), 102 (35), 101 (100), 100 (31), 99 (86), 98 (11), 97 (37), 96 (5), 95 (7), 91 (7), 89 (32), 88 (13), 87 (25), 86 (4), 85 (18), 77 (9), 76 (5), 75 (32), 74 (25), 73 (28), 72 (14), 71 (18), 70 (10).

**1,1-Dibutyl-1-germacyclopent-3-ene (57).** This compound was made according to a modification of the literature procedure.<sup>25</sup> A 100 mL flask with a J. Young valve was charged with germanium diiodide (3.27 g, 10 mmol) and hexane (10 mL). Next the vessel was flushed with argon and cooled to  $-78\text{ }^\circ\text{C}$ . 1,3-Butadiene (0.6 g, 11.1 mmol) was condensed into the vessel then it was sealed. The reaction mixture was stirred at room temperature for 6 h, then heated to  $50\text{ }^\circ\text{C}$  for 2 h. The resulting solution 1,1-diiodo-1-germacyclopent-3-ene was transferred to a flask containing butylmagnesium chloride (20 mL, 40 mmol, 2.0 M in ether) cooled to  $-78\text{ }^\circ\text{C}$ . The reaction mixture was allowed to stir for 15 min, then warm to room temperature and stir for 2 h. The reaction mixture was quenched in HCl (2 M, 100

mL), then extracted with pentane (2 x 75 mL). The combined organic layer was washed with sat. sodium bicarbonate (1 x 75 mL), water (1 x 75 mL), and sat. sodium chloride (1 x 75 mL), then dried over magnesium sulfate. After solvent removal *in vacuo*, distillation provided **57** (1.9 g, 7.9 mmol, 79%) as a clear liquid (b.p. 82-84 °C/2 torr). <sup>1</sup>H NMR (CDCl<sub>3</sub>) δ 5.94 (t, *J* = 0.8 Hz, 2H, ~CH<sub>2</sub>(H)C=C~), 1.43 (d, *J* = 0.8 Hz, 4H, ~CH<sub>2</sub>(H)C=C~), 1.34-1.31 (m, 8H, ~Ge(C<sub>4</sub>H<sub>9</sub>)<sub>2</sub>), 0.93-0.86 (m, 10H, ~Ge(C<sub>4</sub>H<sub>9</sub>)<sub>2</sub>); <sup>13</sup>C NMR (CDCl<sub>3</sub>) δ 131.7, 27.7, 26.3, 16.0, 14.0, 13.9; GC-IR-MS (cm<sup>-1</sup>) 3020, 2965, 2927, 1099. GC-MS (EI): *m/z* 244(4), 242(M<sup>+</sup>, 18), 241(6), 240(13), 238(10), 190(13), 189(6), 188(64), 187(21), 186(49), 185(18), 184(40), 183(10), 181(7), 160(4), 134(16), 133(11), 132(86), 313(47), 130(100), 129(50), 128(76), 127(32), 126(24), 125(14), 113(4), 105(4), 104(5), 103(21), 102(11), 101(29), 100(18), 99(24), 98(4), 97(11), 91(9), 89(37), 88(11), 87(27), 85(20), 76(7), 75(11), 74(31), 73(15), 72(22), 71(6), 70(16), 57(4), 55(8); HRMS (EI) *m/z* calcd for C<sub>12</sub>H<sub>24</sub>Ge 242.109186, found 242.109587.

**(Diethylamino)dimethylchlorogermane (46)**. This compound was made according to the literature procedure.<sup>44</sup> A 500 mL flask was fitted with addition funnel and stirbar. The flask was flushed with argon and charged with ether (400 mL) and diethylamine (36.5 g, 51 mL, 500 mmol). The addition funnel was charged with dimethyldichlorogermane (17.4 g, 11.6 mL, 100 mmol). The flask was cooled to 0 °C and the chlorogermane added. The reaction mixture was stirred at 0 °C for 16 h. Next the salts formed in the reaction were removed by filtration under an inert atmosphere. Distillation after solvent removal *in vacuo* provided **46** (11.6 g, 55 mmol, 55%) as a clear liquid (b.p. 115-116 °C/30 torr, lit. b.p. 177 °C/743 torr<sup>44</sup>). <sup>1</sup>H NMR (CDCl<sub>3</sub>) δ 2.70 (q, *J* = 7.0 Hz, 4H, ~Ge-N(CH<sub>2</sub>CH<sub>3</sub>)<sub>2</sub>), 1.11 (t, *J* = 7.0 Hz, 6H, Ge-N(CH<sub>2</sub>CH<sub>3</sub>)<sub>2</sub>), 0.79 (s, 6H, ~Ge(CH<sub>3</sub>)<sub>2</sub>); <sup>13</sup>C NMR (CDCl<sub>3</sub>) δ 48.2, 18.5, 12.3; GC-MS (EI): *m/z* 211 (M<sup>+</sup>, 3), 209 (2), 198 (10), 197 (3), 196 (23), 195 (6), 194 (18), 192 (11), 178 (3), 177 (1), 176 (9), 175 (2), 174 (8), 172 (6), 161 (4), 160 (2), 159 (5), 157 (3), 141 (29), 140 (7), 139 (52), 138 (11), 137 (41), 135 (25), 111 (8), 109 (14), 108 (2), 107 (12), 105 (11), 91 (4), 89 (12), 88 (3), 87 (8), 86 (2), 85 (6), 73 (24), 72 (44), 58 (100), 56 (23).

**(Diethylamino)dimethylvinylgermane (47).** A 500 mL flask was fitted with an addition funnel and stirbar. The flask was charged with vinylmagnesium bromide (135.5 mL, 135.5 mmol, 1.0 M in THF), and the addition funnel was charged with a solution of (diethylamino)dimethylchlorogermane **46** (26.0 g, 123.2 mmol) in THF (50 mL). The reaction mixture was cooled to  $-78\text{ }^{\circ}\text{C}$  and solution added dropwise. Upon completion, the reaction was allowed to warm to room temperature and stir for 2 h. The magnesium salts were removed by addition of pentane (100 mL) followed by filtration under an inert atmosphere. The product was isolated by distillation which provided **47** (17.0 g, 83.8 mmol) as a clear liquid.  $^1\text{H}$  NMR ( $\text{CDCl}_3$ )  $\delta$  6.31 (dd,  $J = 20, 13.6$  Hz, 1H,  $\sim\text{Ge-CH=CH}_2$ ), 5.97 (dd,  $J = 13.6, 3.2$  Hz, 1H,  $\sim\text{Ge-CH=CH}(\text{cis-H})$ ), 5.97 (dd,  $J = 20, 3.2$  Hz, 1H,  $\sim\text{Ge-CH=CH}(\text{trans-H})$ ), 2.83 (q,  $J = 7.0$  Hz, 4H,  $\sim\text{Ge-N}(\text{CH}_2\text{CH}_3)_2$ ), 0.98 (t,  $J = 7.0$  Hz, 6H,  $\text{Ge-N}(\text{CH}_2\text{CH}_3)_2$ ), 0.31 (s, 6H,  $\sim\text{Ge}(\text{CH}_3)_2$ );  $^{13}\text{C}$  NMR ( $\text{CDCl}_3$ )  $\delta$  132.1, 114.4, 48.2, 18.5, 7.3; GC-MS (EI):  $m/z$  203 ( $\text{M}^+$ , 10), 202 (3), 201 (7), 199 (5), 190 (9), 189 (4), 188 (41), 187 (11), 186 (29), 184 (23), 176 (4), 174 (3), 172 (3), 146 (3), 144 (4), 142 (3), 140 (2), 133 (22), 132 (6), 131 (100), 130 (26), 129 (76), 128 (6), 127 (55), 119 (8), 117 (14), 118 (7), 117 (13), 116 (4), 115 (7), 107 (9), 105 (42), 104 (14), 103 (32), 102 (6), 101 (31), 91 (11), 89 (28), 88 (8), 87 (22), 86 (7), 85 (18), 72 (76), 70 (21), 58 (33), 56 (14).

**Dimethylvinylchlorogermane (48).** This compound was made according to the literature procedure.<sup>45</sup> A 100 mL flask was fitted with addition funnel and stirbar. The flask was flushed with argon and charged with (diethylamino)dimethylvinylgermane **47** (15 g, 73.9 mmol) while the addition funnel was charged with dichlorophenylphosphine (7.96 g, 6 mL, 44.5 mmol). The reaction mixture was cooled to  $0\text{ }^{\circ}\text{C}$  in an ice bath and the dichlorophenylphosphine added slowly. Upon completion of the addition, the reaction mixture was warmed to room temperature and stirred for 6 h. After solvent removal *in vacuo*, the product was isolated by distillation giving **48** (9.6 g, 57.6 mmol, 78%) as a clear liquid (b.p.  $116\text{-}117\text{ }^{\circ}\text{C}/760$  torr, lit. b.p.  $117\text{ }^{\circ}\text{C}/760$  torr<sup>45</sup>).  $^1\text{H}$  NMR ( $\text{CDCl}_3$ )  $\delta$  6.40 (dd,  $J = 19.8, 13.3$  Hz, 1H,  $\sim\text{Ge-CH=CH}_2$ ), 6.09 (dd,  $J = 13.3, 2.3$  Hz, 1H,  $\sim\text{Ge-CH=CH}(\text{cis-H})$ ), 5.84 (dd,  $J = 19.8, 2.3$  Hz, 1H,  $\sim\text{Ge-CH=CH}(\text{trans-H})$ ), 0.77 (s, 6H,  $\sim\text{Ge}(\text{CH}_3)_2$ );  $^{13}\text{C}$  ( $\text{CDCl}_3$ )  $\delta$

128.6, 112.5, 14.2, GC-MS (EI):  $m/z$  166 ( $M^+$ , 2), 164 (1), 153 (41), 152 (9), 151 (100), 150 (20), 149 (76), 147 (44), 141 (9), 139 (21), 138 (6), 137 (16), 135 (10), 131 (19), 130 (5), 129 (17), 127 (26), 126 (10), 125 (37), 124 (22), 123 (33), 122 (14), 121 (19), 111 (19), 109 (40), 107 (37), 105 (42), 103 (21), 101 (22), 91 (8), 89 (31), 88 (16), 87 (28), 86 (8), 85 (19), 75 (12), 74 (19), 73 (14), 72 (13), 71 (7), 70 (10).

**( $\alpha$ -Bromovinyl)dimethylchlorogermane (49).** A 25 mL round bottom flask was fitted with stirbar and addition funnel and charged with dimethylvinylchlorogermane **47** (1.5 g, 7.4 mmol). The addition funnel was charged with bromine (1.5 g, 0.48 mL, 9.8 mmol). The flask was cooled to  $-78$  °C and the bromine slowly added dropwise with stirring. After completion of addition the reaction mixture was warmed to room temperature for 15 min, then cooled to 0 °C in an ice bath and triethylamine (4.48 g, 6.12 mL, 44.34 mmol) was added slowly. The reaction mixture was stirred for 2 h at room temperature after the addition was complete. The salts were removed by filtration under an inert atmosphere. The compound was purified by distillation, which provided **49** (1.13 g, 4 mmol, 54%) as a clear liquid.  $^1\text{H}$  NMR ( $\text{CDCl}_3$ )  $\delta$  6.47 (d,  $J = 2.3$  Hz, 1H,  $\sim\text{Ge}(\text{Br})\text{C}=\text{CH}$  *cis*-H)), 6.40 (d,  $J = 2.3$  Hz, 1H,  $\sim\text{Ge}(\text{Br})\text{C}=\text{CH}$  (*trans*-H)), 0.86 (s, 6H,  $\sim\text{Ge}(\text{CH}_3)_2$ ),  $^{13}\text{C}$  NMR ( $\text{CDCl}_3$ )  $\delta$  132.4, 130.1, 14.6, GC-MS (EI):  $m/z$  249 (6), 248 (6), 247 (6), 245 (7), 244 ( $M^+$ , 18), 243 (3), 242 (13), 240 (5), 233 (8), 231 (23), 239 (6), 229 (31), 228 (4), 227 (22), 225 (8), 209 (5), 207 (27), 206 (4), 205 (71), 204 (13), 203 (100), 202 (10), 201 (68), 199 (24), 185 (10), 184 (3), 183 (15), 182 (3), 181 (11), 179 (6), 168 (3), 167 (5), 166 (3), 165 (8), 164 (3), 163 (6), 161 (4), 155 (12), 154 (2), 153 (16), 152 (3), 151 (13), 149 (6), 141 (18), 140 (4), 139 (43), 138 (9), 137 (32), 135 (18), 126 (3), 124 (6), 123 (4), 122 (6), 120 (3), 111 (14), 110 (3), 109 (29), 108 (5), 107 (30), 106 (3), 105 (18), 104 (3), 99 (9), 98 (4), 97 (7), 95 (5), 91 (3), 89 (15), 88 (8), 87 (14), 86 (7), 85 (10), 84 (3), 81 (3), 79 (3), 76 (2), 75 (3), 74 (10), 73 (5), 72 (7), 71 (2), 70 (5).

**2,4-Dimethylene-1,1,3,3-tetramethyl-1,3-digermacyclobutane (50).** A 3-neck 100 mL flask was fitted with addition funnel and reflux condenser. The apparatus was flushed with argon, and then charged with magnesium turnings (0.6

g, 24.3 mmol) and dry THF (50 mL). The addition funnel was charged with **49** (5.4 g, 22 mmol) and dry THF (10 mL). The reaction mixture was activated by the addition of 0.2 mL of ethylene dibromide. The chlorogermanane **49** was then added slowly to maintain reflux. After the addition was complete, the reaction mixture was refluxed for a further 3 h. The reaction mixture was filtered to remove magnesium salts, then hexane (75 mL) was added and the solution filtered again. GC-MS analysis of this solution showed the presence of **50** and the trimer. The solvent was then removed by distillation through a 30 cm column packed with glass helices. The remaining material was a clear oil, and analysis showed that **50** had decomposed during solvent removal. GC-MS-IR ( $\text{cm}^{-1}$ ) 3100, 2929, 1741, 1555, 1418, 1234, 841, 831. GC-MS (EI):  $m/z$  262(8). 260 ( $\text{M}^+$ , 25), 259 (12), 258 (32), 257 (9), 256 ( $\text{M}^+$ , 34), 255 (7), 254 (16), 247 (9), 245 (34), 244 (13), 243 (46), 242 (13), 241 (43), 240 (7), 239 (23), 237 (7), 210 (5), 208 (10), 206 (14), 204 (15), 203 (7), 202 (8), 195 (8), 193 (28), 192 (12), 191 (37), 190 (9), 189 (39), 188 (10), 187 (19), 185 (11), 178 (6), 177 (7), 176 (8), 175 (7), 173 (9), 172 (7), 171 (12), 162 (5), 161 (14), 159 (12), 158 (5), 157 (13), 155 (10), 153 (5), 147 (5), 145 (8), 144 (5), 143 (9), 141 (19), 139 (15), 137 (14), 131 (8), 129 (24), 128 (7), 127 (14), 125 (14), 123 (6), 121 (24), 120 (6), 119 (100), 118 (25), 117 (73), 116 (7), 115 (60), 114 (9), 113 (16), 112 (98), 111 (13), 109 (9), 106 (6), 105 (17), 104 (24), 103 (17), 102 (15), 101 (20), 100 (14), 99 (29), 98 (5), 97 (10), 95 (1), 91 (23), 89 (85), 88 (30), 87 (68), 80 (16), 79 (50), 75 (10), 74 (12), 73 (10), 72 (11), 71 (10), 70 (8), 65 (5), 63 (4), 61 (6), 58 (6), 56 (5), 55 (4).



**References**

- (1) Conlin, R. T.; Huffaker, H. B.; Kwak, Y. *J. Am. Chem. Soc.* **1985**, *107*, 731.
- (2) Barton, T. J.; Lin, J.; Ijadi-Maghsoodi, S.; Power, M. D.; Zhang, X.; Ma, Z.; Shimizu, H.; Gordon, M. S. *J. Am. Chem. Soc.* **1995**, *117*, 11695.
- (3) Chan, T. H.; Massuda, D. *J. Am. Chem. Soc.* **1977**, *99*, 936.
- (4) Barton, T. J.; Yeh, M. H. *Tetrahedron Lett.* **1987**, *28*, 6421.
- (5) Eaton, P. E.; Hoffman, K. *J. Am. Chem. Soc.* **1987**, *109*, 5825.
- (6) Chen, N.; Jones, M. J. *J. Phys. Org. Chem.* **1988**, *1*, 305.
- (7) Raghavachari, K.; Frisch, M. J.; Pople, J. A.; Schleyer, P. V. R. *Chemical Physics Letters* **1982**, *85*, 145.
- (8) Nobles, R. H.; Radom, L.; Rodwell, W. R. *Chem. Phys. Lett.* **1980**, *74*, 269.
- (9) Jensen, J. H.; Morokuma, K.; Gordon, M. S. *J. Chem. Phys.* **1994**, *100*, 1981.
- (10) Barton, T. J.; Groh, B. L. *Organometallics* **1985**, *4*, 575.
- (11) Goerge, P.; Trachtman, M.; Bock, C. W.; Brett, Q. M. *Tetrahedron* **1976**, *32*, 317.
- (12) Chesick, J. P. *J. Phys. Chem.* **1961**, *65*, 2170.
- (13) Flowers, M. C.; Gusel'nikov, L. E. *J. Chem. Soc. B* **1968**, 419.
- (14) Genaux, C. T.; Kern, F.; Walters, W. D. *J. Am. Chem. Soc.* **1953**, *75*, 6196.
- (15) Davidson, I. M. T.; Eaton, G.; Hughes, K. J. *J. Organomet. Chem.* **1988**, 347, 17.
- (16) Damrauer, R. *Organometal. Chem. Rev. A* **1972**, *8*, 67.
- (17) Nametkin, N. S.; Gusel'nikov, L. E.; Ushakova, R. L.; Orlov, V. Y.; Kuz'min, O. V. *Dokl. Akad. Nauk. SSSR* **1970**, *194*, 741.
- (18) Conlin, R. T. *Organometallics* **1992**, *11*, 3307.
- (19) Jackson, R. A. *J. Organometal. Chem.* **1979**, *166*, 17.
- (20) Dzamoski, J.; Ring, M. A.; O'Neal, H. E. *Int. J. Chem. Kinet.* **1981**, *14*, 279.
- (21) Smith, G. P.; Patrick, R. *Int. J. Chem. Kinet.* **1983**, *15*, 167.
- (22) Barton, T. J.; Marquardt, G.; Kilgour, J. A. *J. Organometal. Chem.* **1975**, *85*, 317.

- (23) Rieke, R.; Bales, S. E. *J. Am. Chem. Soc.* **1974**, *96*, 1775.
- (24) Mirinov, V. F.; Kravchenko, A. L. *Izv. Akad. Nauk. SSSR.* **1965**, *6*, 1026.
- (25) Takeuchi, Y.; Tanaka, K.; Harazono, T. *Bull. Chem. Soc. Jpn.* **1991**, *64*, 91.
- (26) Lei, D.; Gaspar, P. P. *Polyhedron* **1991**, *18*, 1221.
- (27) Clarke, M. P.; Davidson, I. M. T. *Organometallics* **1988**, *7*, 2076.
- (28) Ando, W.; Tsumuraya, T. *Organometallics* **1989**, *8*, 2759.
- (29) Riviere, P.; Castel, A.; Satge, J.; Guyot, D. *J. Organomet. Chem.* **1986**, *315*, 157.
- (30) Tillman, N. *Gas phase thermal interconversions of silacyclobutanes, alkylsilanes and silacyclopropanes*; Iowa State University: Ames, 1986.
- (31) Becerra, R.; Walsh, R. *J. Organometal. Chem.* **2001**, *636*, 49.
- (32) Baldwin, A. C.; Davidson, I. M. T.; Howard, A. V. *J. Chem. Soc., Faraday Trans. I* **1975**, *71*, 972.
- (33) Hutzinger, M. W.; Oehlschlager, A. C. *J. Org. Chem.* **1995**, *60*, 4595.
- (34) Brandsma, L. *Preparative Acetylenic Chemistry*; 2nd ed.; Elsevier: Amsterdam, New York, 1988.
- (35) Mazerolles, P.; Dubac, J.; King, R. B. and Eisch, J. J., Ed.; Elsevier: New York, 1986, pp 555.
- (36) Brook, A. G.; Peddle, G. J. D. *J. Am. Chem. Soc.* **1963**, *85*, 1869.
- (37) Tabern, D. L.; Orndorff, W. R.; Dennis, L. M. *J. Am. Chem. Soc.* **1925**, *47*, 2043.
- (38) Andersen, H. H. *J. Am. Chem. Soc.* **1949**, *71*, 1799.
- (39) Orndorff, W. R.; Tabern, D. L.; Dennis, L. M. *J. Am. Chem. Soc.* **1927**, *49*, 2512.
- (40) Andersen, H. H. *J. Am. Chem. Soc.* **1951**, *73*, 5800.
- (41) Rochow, E. G. *J. Am. Chem. Soc.* **1950**, *72*, 198.
- (42) Andersen, H. H. *J. Am. Chem. Soc.* **1961**, *83*, 547.
- (43) Cousseau, J. *Synthesis* **1980**, 805.
- (44) Yoder, C. H.; Zuckerman, J. J. *J. Am. Chem. Soc.* **1966**, *88*, 4831.
- (45) Betka, K.; Grobe, J. *J. Organometal. Chem.* **1981**, *210*, 19.

## Appendix. Mass spectra of methylenegermacyclobutanes

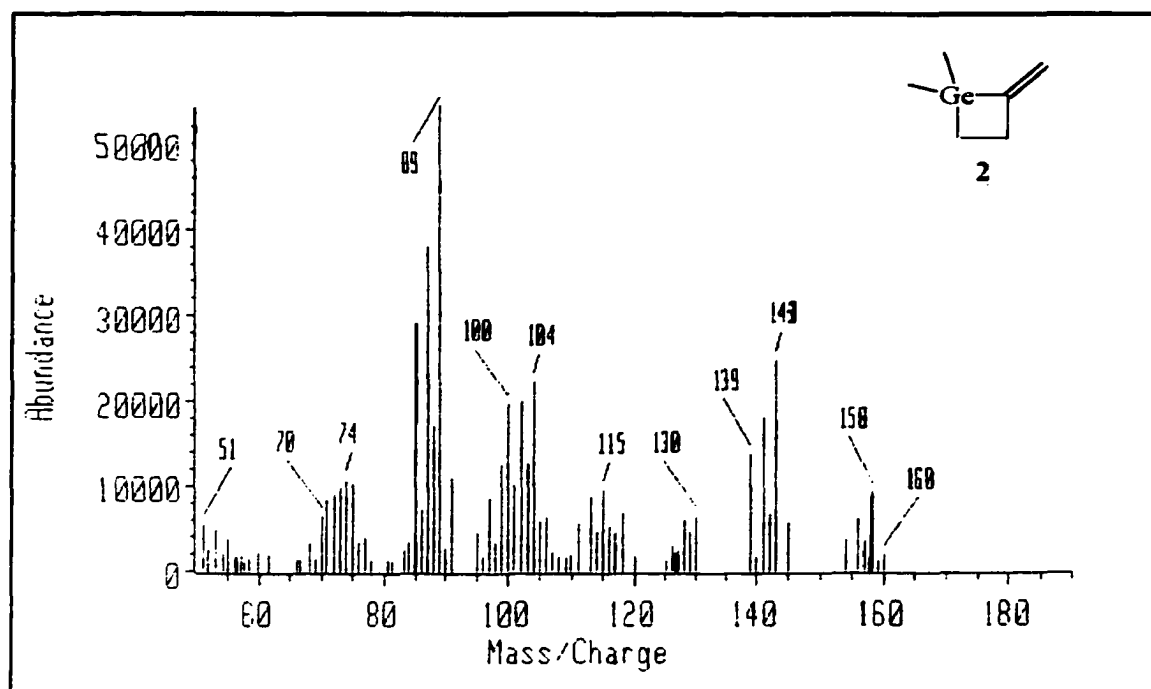

Figure 1. Mass spectrum of 1,1-dimethyl-2-methylenegermacyclobutane (2).

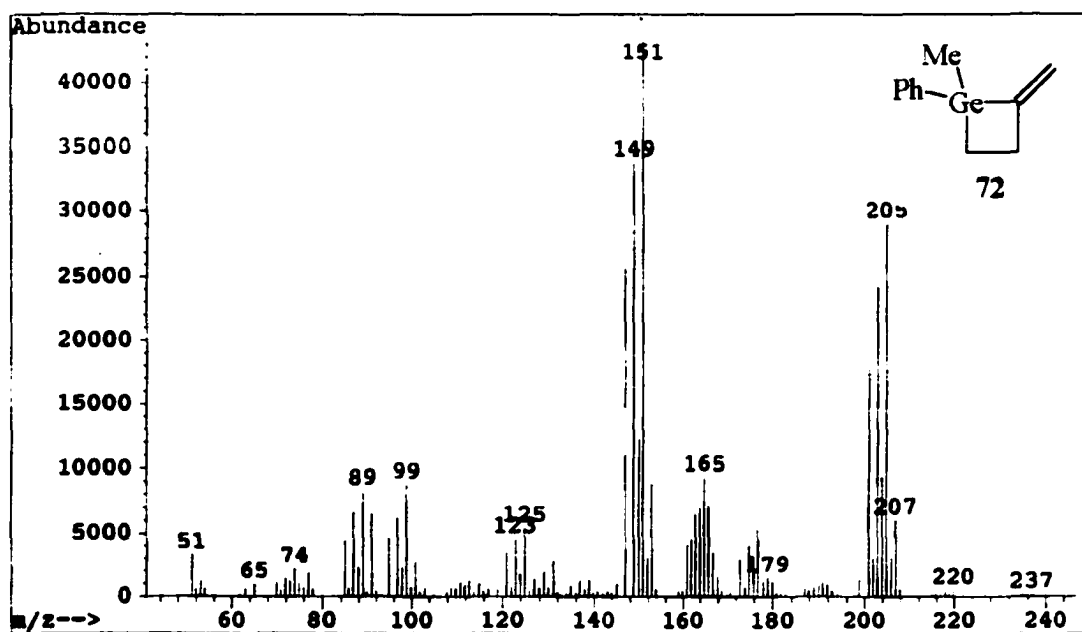

Figure 2. Mass spectrum of 1-methyl-2-methylene-1-phenylgermacyclobutane (72).

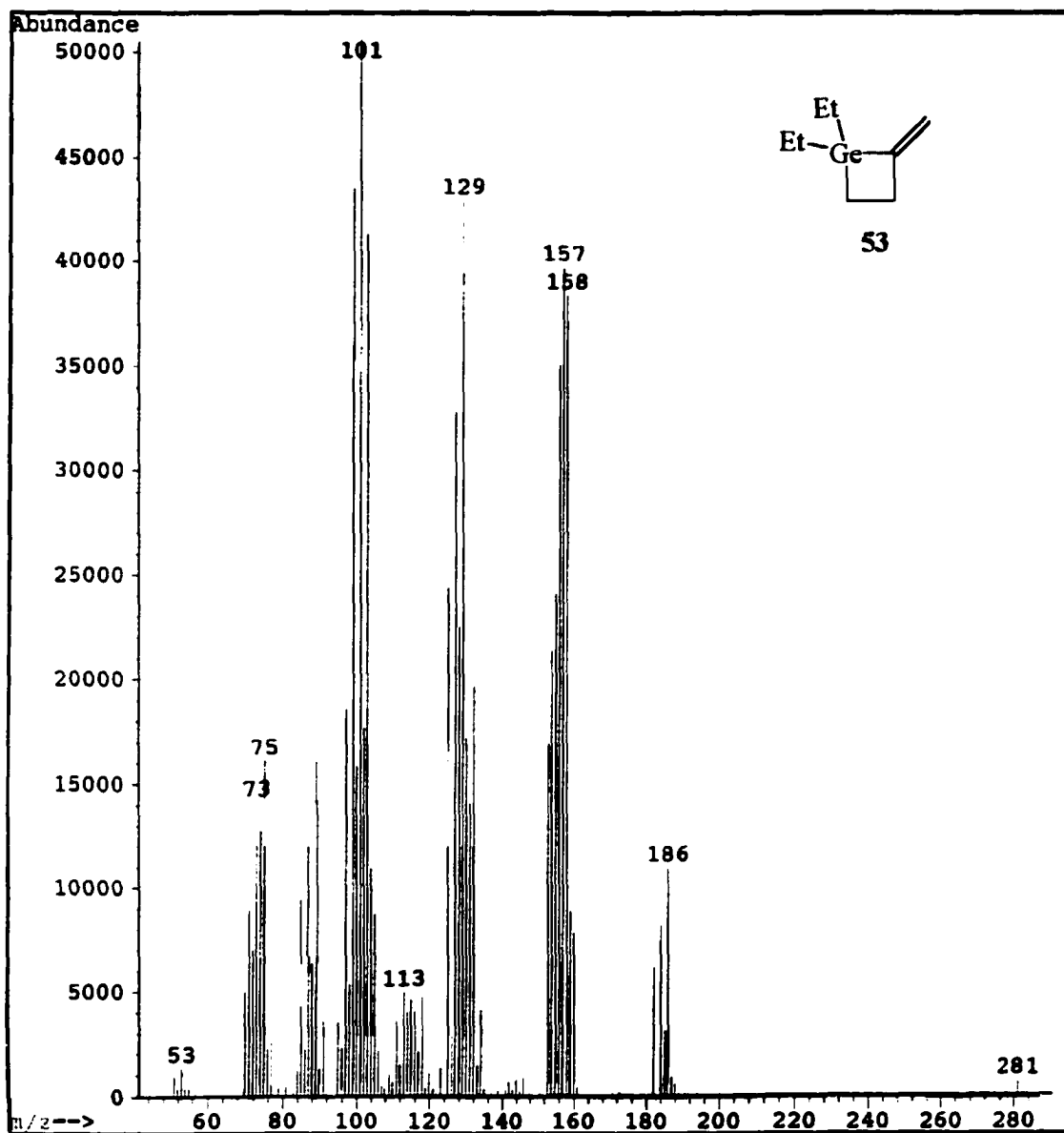

Figure 3. Mass spectrum of 1,1-diethyl-2-methylenegermacyclobutane (53).

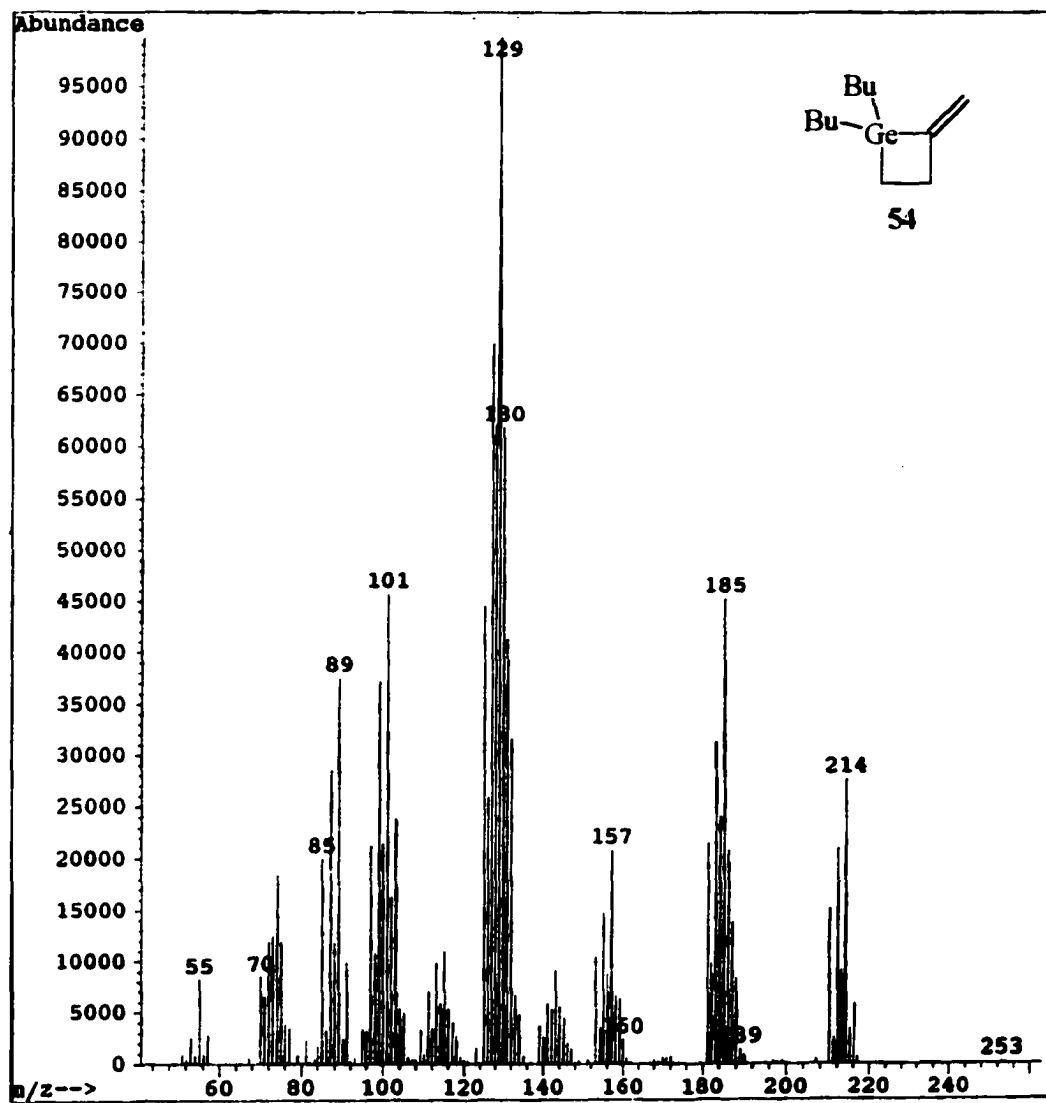

Figure 4. Mass spectrum of 1,1-dibutyl-2-methylenegermacyclobutane (54).

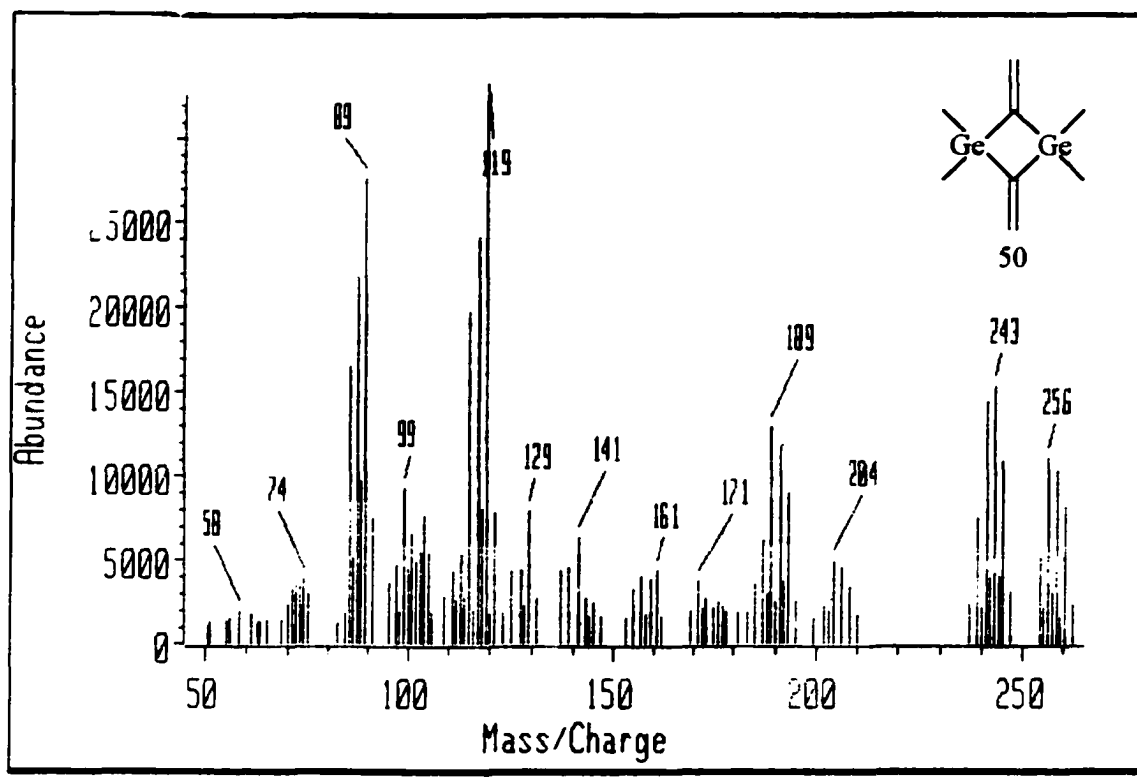

Figure 5. Mass spectrum of 2,4-dimethylene-1,1,3,3-tetramethyl-1,3-digermacyclobutane (50).

## **CHAPTER 2. THERMAL BEHAVIOR OF VARIOUS ORGANOGERMANIUM COMPOUNDS**

### **Introduction and Literature Survey**

Germanium has many important commercial uses, although the domestic (US, 2000) consumption of germanium was only 28,000 kg. The applications of germanium (and its compounds) include fiber optics (50%), polymerization catalysts (25%), infrared-optics (15%), electrical/solar applications (5%), and other uses (phosphors, metallurgy, and chemotherapy) 5%.<sup>1</sup> The main use of germanium in fiber optics is as germanium dioxide, used as dopant in the core of optical fiber to reduce signal attenuation. Germanium, being transparent to IR light, is used in high-end infrared optical systems, mainly in military guidance and weapons systems, although General Motors has recently offered its Night Vision system on Cadillac Deville models as an option. The system is a thermal imaging system that uses a germanium lens. Multijunction (GaAsP<sub>2</sub>/ GaAs/ Ge) solar cells are currently being used in spacecraft and satellites, offering the highest efficiency of any solar cells available. Germanium is expected to see increasing use in microelectronics applications. New SiGe technology has been developed and is entering production. The alloying of germanium with silicon allows the band gap and electronic properties of the material to be tailored to the application, while still using conventional Si processing technology.

The chief method for the formation of microelectronic devices is metal organic chemical vapor deposition (MOCVD). The germanium precursor most commonly used for the manufacture of germanium containing devices is GeH<sub>4</sub>. The use of germane poses some difficulty in handling and processing, since it is a pyrophoric gas. Many other germanium compounds have been examined in the search for a suitable MOCVD precursor that would be useful in the fabrication of germanium metal films for use in various applications. Among them are tetralkylgermanes and

alkylgermanes. The following is a brief review of what is currently known about the thermal behavior of some alkylgermanes, including germane, methylgermane, trimethylgermane, tetramethylgermane, ethylgermane, diethylgermane, triethylgermane, tetraethylgermane, tetrapropylgermane and tetrabutylgermane.

### Germane (1)

The thermal decomposition of germane (1) is generally thought to produce only germanium metal and 2 molecules of hydrogen.

Scheme 1. Overall decomposition of germane (1)



The kinetics of thermal germane decomposition has been studied quite extensively. However, the literature kinetic data is often not in agreement. The reason for this is the decomposition of germane is a complex process, reported to involve parallel homogenous and heterogeneous pathways.<sup>2-5</sup> The heterogeneous pathway is largely dependant on the specific surface area of the reactor, the material of the reactor walls, as well as temperature and concentration.<sup>6-11</sup> Thus, according to the previously cited literature, the reported activation energy for the heterogeneous zero order surface pathway vary from 17-42 kcal/mol. The first order homogenous gas phase pathway is reported to have an activation energy of around 51.4-54.3 kcal/mol.<sup>3,9,12-14</sup> However, care must be taken when using the data reported, as it seems the kinetics of even the homogenous gas phase decomposition of germane depends on the surface type under those conditions<sup>6,13</sup>(see Table 1).



Table 1. Static system thermal decomposition rate constants for germane (1).<sup>13</sup>

Arrhenius Parameters: Over a Germanium film		Ref.
log $k_0$ (zero order, torr/sec)	log $k_1$ (first order, torr/sec)	
13.62 – 41.9 kcal	15.47 – 51.40 kcal	3
11.64 – 37.56 kcal	15.53 – 53.40 kcal	6
15.46 – 42.74 kcal	16.33 – 54.07 kcal	13

Table 2. Rate constants of thermolysis of germane (1) over glass and Ge film.<sup>13</sup>

T (°C)	Glass Surface		Germanium Film	
	$k_0$ (torr/sec)	$k_1$ (torr/sec)	$k_0$ (torr/sec)	$k_1$ (torr/sec)
338	0.0248	0.00106	0.158	0.000338
326	0.00792	0.000595	0.104	0.000121

The values above illustrate the importance of the surface type in static systems. The decomposition was also studied using the comparative-rate single-pulse shock tube method, where surface reactions are eliminated. Arrhenius parameters of  $\log k = 13.83$  and  $E_a = 50.7 \pm 3.6$  were measured for the first order homogenous gas phase decomposition using this shock tube method.<sup>13</sup> The proposed rate-determining step is shown in Scheme 1 as the three-center elimination of hydrogen from germane. This is quite reasonable since the activation energies reported of around 50 kcal/mol are far too low to be simple homolytic cleavage of a Ge-H bond (approximately 83 kcal/mol). Subsequent reactions are the elimination of H<sub>2</sub> from germylene giving germanium metal, or the loss of a proton giving GeH. Both processes have a barrier lower than that of the rate-determining

step. Labeling experiments using  $\text{GeD}_4$ /toluene (ratios of 1:10 and 1:100  $\text{GeD}_4$ /toluene were used) revealed the production of HD ( $\text{HD}/\text{D}_2 = 0.11$ ) in small amounts. The  $\text{HD}/\text{D}_2$  ratio was independent of concentration. The ratio is consistent (assuming all proton abstraction is from toluene) with the two secondary reactions being in competition, with the loss of a proton being a minor process.

Scheme 2. Mechanism of the thermal decomposition of germane (1)<sup>13</sup>

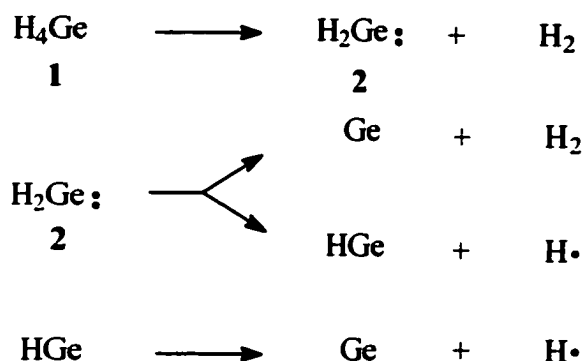

While many of the previous workers had measured kinetics by change in pressure,<sup>2-7</sup> or by decrease in germane concentration,<sup>13</sup> the work of Votintsev and coworkers followed the formation of Ge atoms by atomic absorption spectroscopy in shock tube experiments.<sup>12</sup> Arrhenius parameters of  $E_a = 52.1$  kcal/mol, and  $\log A = 15.4$  were obtained, which are in agreement with previous work. In addition a full energy diagram was calculated (Figure 1). The mechanism proposed was similar to that of Newman et al. shown above. The authors calculated the secondary route of proton loss from germylene (2) accounted for 5% of the decomposition. This is consistent with the  $\text{HD}/\text{D}_2$  ratio of 0.11 obtained by Newman, since  $\text{H}_2\text{Ge:}$  produces two protons.

An induction period is typically observed in these experiments when an uncoated reactor is used.<sup>4,6,13</sup> The induction period was shorter at higher temperatures, and was explained by Newman and coworkers to be the time required to build a germanium film on the reactor surface.

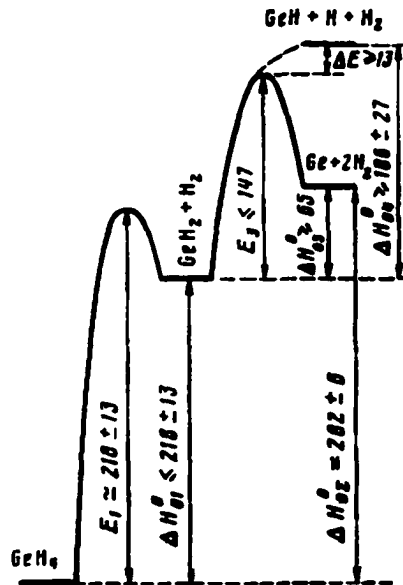

Figure 1. Energy diagram for the decomposition of germane.<sup>12</sup>

The unimolecular decomposition pathway was thought to be the mechanism by which this occurs, since the activation energy of the induction period (49.4 kcal/mol at 200 torr, 571-624 K) is close to the calculated value for that process under those conditions.

The effects of different reactor surface materials and additives in static systems were further explored by Azatyan and coworkers.<sup>11</sup> The addition of hydrogen was shown to increase the observed induction time, as did the addition of propylene to the reaction mixture. Propylene being a good radical trap, the authors proposed that the role of chain radicals is more important than previously thought. The time of evacuation of the reaction vessel prior to the thermolysis also effected the induction time, increasing it. This was due to the removal of active intermediate particles absorbed on the reactor surface, particles which help to accelerate the reaction. An increase in the surface/volume ratio also increases the reaction rate, which is not unexpected if absorbed active particles accelerate the reaction. The data above shows the importance of the heterogeneous reaction pathway in the thermal decomposition of germane under static conditions.

Methylgermane (3)

The thermolysis of methylgermane was first examined by Ring and coworkers, who reported the products from the thermolysis in a flow system. The reported products were CH<sub>4</sub>, H<sub>2</sub>, dimethylgermane, and trace amounts of 1,2-dimethyldigermane. The products being similar to the decomposition of methylsilane, which was believed to decompose through H<sub>2</sub> elimination as the primary process.<sup>15</sup> A later study by O'Neal and Ring<sup>16</sup> examined the Arrhenius parameters and mechanism of the decomposition of methylgermane using a single-pulse shock tube method. The experiments were carried out in the presence of toluene, which serves as a free radical trap. The products observed were H<sub>2</sub>, CH<sub>4</sub>, and C<sub>2</sub>H<sub>6</sub>, with a trace of benzene and ethylbenzene. The primary processes of methylgermane **3** decomposition are shown in Scheme 3. Both the observed H<sub>2</sub> and CH<sub>4</sub> were found to be the result of three-center elimination processes, while a third process involving a four-center elimination of H<sub>2</sub> was also proposed.

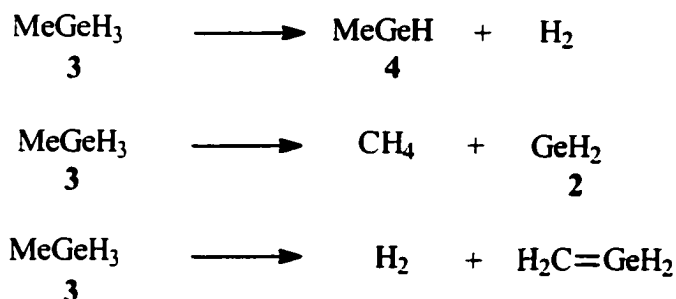
Scheme 3. Primary modes of methylgermane (**3**) decomposition.<sup>16</sup>

The homolytic cleavage of the methyl-germanium bond was not thought to be a primary process. The source of methyl radicals being a secondary process, shown in Scheme 4 as the loss of a methyl radical from methylgermylene (**4**). The observed rate of methyl radical production is orders of magnitude faster than expected for the primary process (Ge-Me bond cleavage in methylgermane (**3**)).

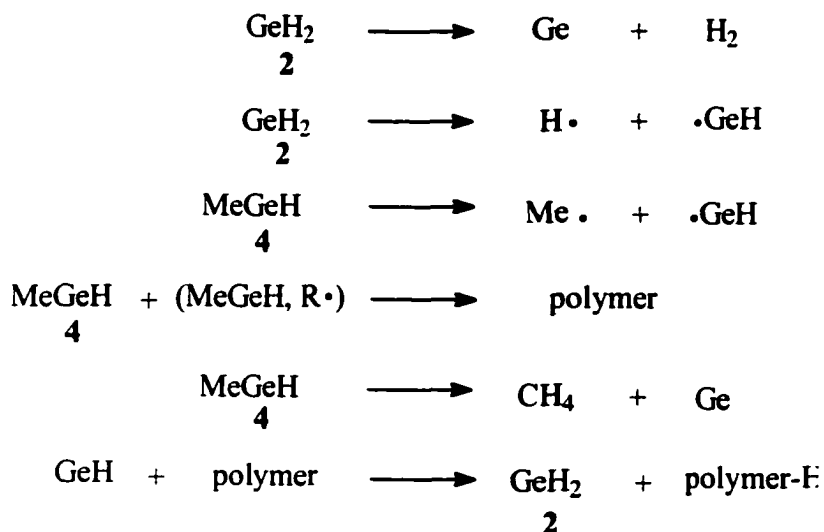
Scheme 4. Possible secondary processes of the decomposition of 3.<sup>16</sup>

In addition, no germane is observed. Germane would be expected since H abstraction by the germyl radical would most likely occur in the presence of excess toluene.

A number of shock experiments using deuterium-labeled systems were carried out in order to elucidate the primary decomposition pathways. The summary of the results of methylgermane-d<sub>3</sub> (3D)/toluene-d<sub>8</sub> shock tube experiment are shown in Table 3. The amount of hydrogen produced relative to decomposition of methylgermane increases with increasing temperature. The experiment produced D<sub>2</sub> in large amounts, evidence for the elimination of hydrogen from germanium as a primary process. Also, HD was produced, the most likely source of which is the four-center elimination of hydrogen, giving germene (shown in Scheme 3). Although not considered by the authors, HD could also be produced from the reversible isomerization of D(Me)Ge: to germene. This isomerization would certainly cause deuterium scrambling into the methyl group. Subsequent decomposition, shown in Scheme 5, would give a proton that, upon deuterium abstraction from toluene-d<sub>8</sub>, provides HD.

Scheme 5. Route of HD production through methygermylene isomerization

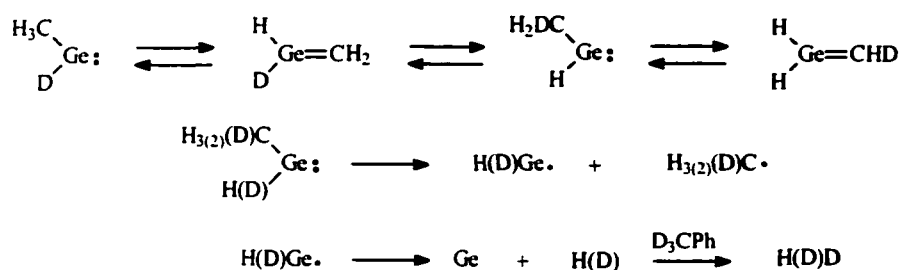

An analysis of the hydrocarbons produced in the shock tube experiment using methylgermane (**3**) in toluene- $d_8$  can be used support the participation of the molecular elimination of methane from methylgermane (**3**) as a primary process (Table 4).

Table 3. Hydrogen produced in the decomposition of methylgermane- $d_3$  (**3D**) in the presence of toluene- $d_8$ .<sup>16</sup>

Temp (K)	% Decomp.	$\Delta(\text{tot. hydrogen})/$ $\Delta\text{MeGeD}_3$	$\Delta\text{D}_2/\Delta\text{MeGeD}_3$	$\Delta\text{HD}/\Delta\text{meGeD}_3$
1065	30	1.013	0.743	0.270
1172	95.6	1.444	1.102	0.343

Table 4. Summary of hydrocarbon yields for the thermal decomposition of methylgermane (**3**) in the presence of toluene- $d_8$ .<sup>16</sup>

Temp (K)	% Decomp.	$\Delta(\text{CH}_4)/$ $\Delta\text{MeGeH}_3$	$\Delta(\text{CH}_3\text{D})/$ $\Delta\text{MeGeH}_3$	$\Delta\text{C}_2\text{H}_6/$ $\Delta\text{MeGeH}_3$
1083	28	0.289	0.048	0.094
1150.4	79.3	0.294	0.137	0.100

The unlabeled methane produced in the reaction must come from the aforementioned elimination. Abstraction of a deuterium from toluene-d<sub>8</sub> and dimerization of the methyl radical explains the presence of CH<sub>3</sub>D and ethane respectively.

Arrhenius parameters of the primary processes of methylgermane (**3**) thermal decomposition were measured (shown in Table 5).

Table 5. Primary processes of methylgermane (**3**) thermal decomposition.<sup>16</sup>

reaction	% of pathway occurring	Experimental (p = 3100 torr, 1050-1250 K)		High Pressure (RRKM calculated)	
		log A(exptl)	Ea(exptl) kcal/mol	log A( $\infty$ )	Ea( $\infty$ ) kcal/mol
3-center H <sub>2</sub> elimination	40%	12.96	50.4	14.57	57.6
3-center CH <sub>4</sub> elimination	30%	13.08	51.6	14.93	59.7
4-center H <sub>2</sub> elimination	30%	13.04	51.6	14.71	58.9

The authors conclude that the primary processes involved are three-center H<sub>2</sub> elimination which accounts for 40% of the overall reaction, three-center CH<sub>4</sub> elimination which accounts for 30% of the overall reaction, and the novel four-center H<sub>2</sub> elimination, which accounts for the remaining 30% of the overall reaction. Although the presence of methyl radicals is evident, these are produced through secondary processes.

Trimethylgermane (5)

The mechanism of the thermal decomposition of trimethylgermane (5), based on product distribution and trapping experiments, were first reported by Paquin. The flow pyrolysis of trimethylgermane (5) at 470 °C was performed. The products are shown in Scheme 6.<sup>17</sup>

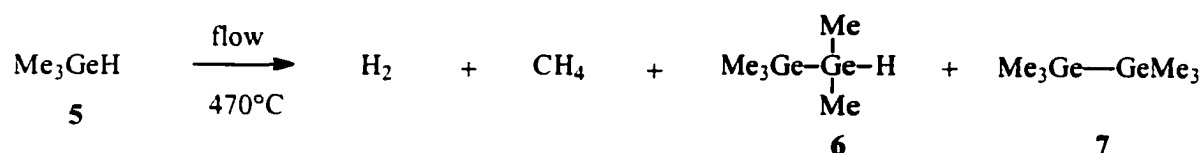
Scheme 6. Products of trimethylgermane (5) decomposition.<sup>17</sup>

The ratio of H<sub>2</sub>/CH<sub>4</sub> was 30/1 while that of pentamethyldigermene 6/hexamethyldigermene (7) was 4/1. The digermene products demonstrate the presence of dimethylgermylene (8), since the digermene 6 is the product of dimethylgermylene insertion into the Ge-H bond of trimethylgermane (5). The presence of trimethylgermyl radical is also indicated, since the digermene 7 is presumably the product of trimethylgermyl radical homocoupling. The authors proposed the following mechanism (Scheme 7).

The pyrolysis of trimethylgermane (5) in the presence of 1,3-butadiene also provided evidence for the intermediacy of trimethylgermyl radicals and dimethylgermylene (8). The digermene (6 and 7) products in this pyrolysis were absent, instead 1-trimethylgermyl-2-butene (9) and 1,1-dimethyl-1-germacyclopent-3-ene (10) were observed. The germacyclopentene 10 comes from the addition of dimethylgermylene (8) to 1,3-butadiene, while the butene 9, was proposed to come from the addition trimethylgermyl radical to 1,3-butadiene followed by hydrogen abstraction (Scheme 8).

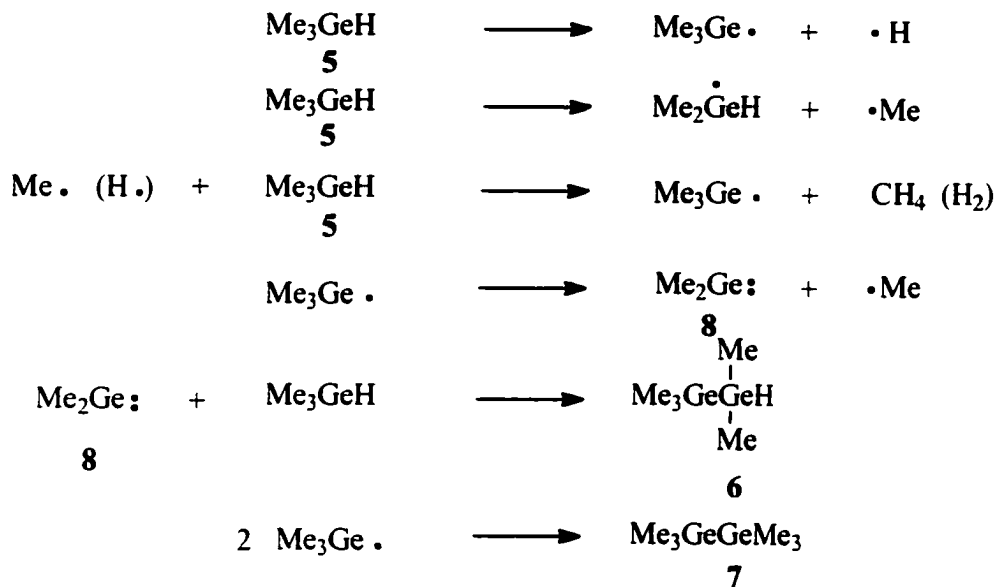
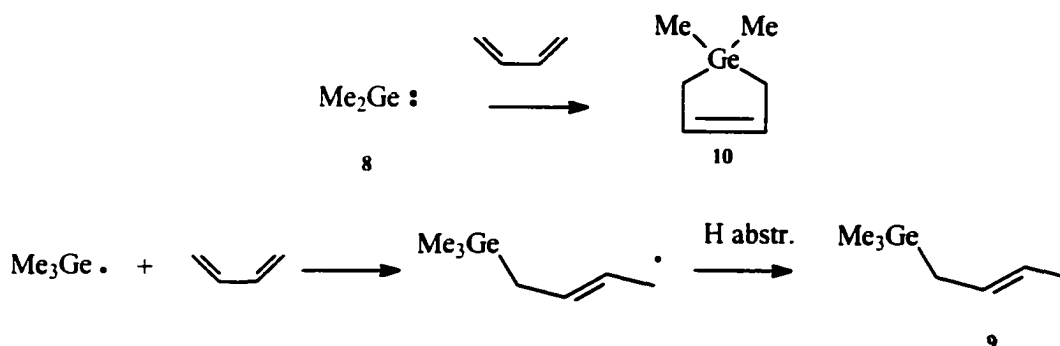

Scheme 7. Proposed mechanism of trimethylgermane (**5**) thermal decomposition.<sup>17</sup>Scheme 8. Trapping products of the pyrolysis of trimethylgermane (**5**) in the presence of 1,3-butadiene.<sup>17</sup>

However, the butene **9** is more likely the result of the thermal hydrogermylation of 1,3-butadiene by trimethylgermane (**5**). Hydrogermylation of 1,3-dienes usually proceeds through 1,4 addition with and without catalyst.<sup>18-21</sup> Unlike the silicon analog,<sup>22</sup> no metallocyclobutanes were observed, suggesting that the double-bonded species dimethylgermene is not an important intermediate in the decomposition.

Later studies by Harrison and coworkers expanded upon this work by examining the decomposition of trimethylgermane-d (**5D**) through FTIR.<sup>23</sup> His experiments (performed at 673-873 K) showed that CH<sub>3</sub>D, CH<sub>4</sub> and a transient trimethylgermane (**5**) were produced in the pyrolysis. Arrhenius parameters were also measured base on the data collected, giving an  $E_a = 62.1$  kcal/mol for trimethylgermane. The process was found to be a half-order process (with respect to trimethylgermane), and was inhibited by the presence of the free radical scavengers nitric oxide and methyl iodide, suggesting a free radical chain mechanism (Scheme 9).

Scheme 9. Proposed mechanism of trimethylgermane-d (**5D**) thermal decomposition.<sup>23</sup>

Initiation:

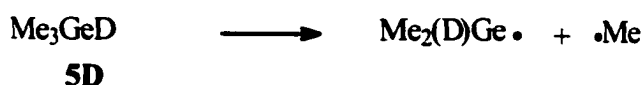

Propagation:

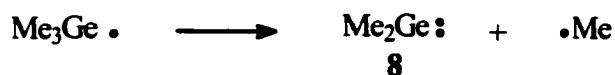
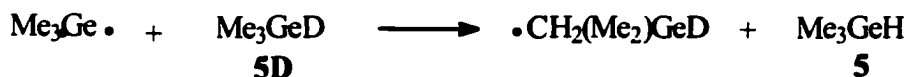
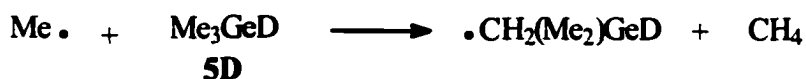
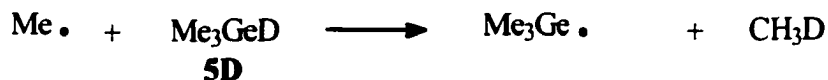

Termination:



Tetramethylgermane (11)

The thermolysis of tetramethylgermane (11) produces mainly ethene, ethane, and small amounts of higher hydrocarbons. The ratio of hydrocarbons appears to depend on the temperature and percent conversion. Table 6 shows the hydrocarbons produced in a wall-less reactor under homogenous conditions, and in the presence surface effects (accomplished by using a stainless steel insert).<sup>24</sup>

Table 6. Products of decomposition of tetramethylgermane (11).<sup>24</sup>

Type	Temp (°C)	Conv. %	Mol % Yield				C <sub>2</sub> H <sub>4</sub> / C <sub>2</sub> H <sub>6</sub>	C <sub>1</sub> /C <sub>2</sub>
			CH <sub>4</sub>	C <sub>2</sub> H <sub>6</sub>	C <sub>2</sub> H <sub>4</sub>	C <sub>3</sub> H <sub>6</sub>		
Hom.	649	1	0.2	0.44	0.36		0.82	0.25
	712	7	1.5	3.0	2.5		0.83	0.27
	761	30	5.4	16.0	8.0	0.16	0.48	0.22
Surf.	630	1	0.55	0.29	0.16		0.55	1.22
	674	7	2.9	2.4	1.7	<0.01	0.71	0.71
	714	30	10.1	12.1	7.7	0.14	0.64	0.51

The kinetic data obtained (homogenous conditions) showed the slope of the Arrhenius plot changed at around 710 °C. Above 710 °C, the Arrhenius parameters were reported as  $E_a = 69$  kcal/mol and  $\log A = 15.1$ , while below 710 °C they were reported as  $E_a = 51$  kcal/mol and  $\log A = 12.1$ . The data obtained in the presence of surface effects showed a linear plot, corresponding to  $E_a = 75$  kcal/mol and  $\log A = 17.0$  although this data was not very reproducible.

The proposed mechanism (for the reaction above 710 °C) in Scheme 10 shows the primary decomposition as the homolytic cleavage of a Ge-Me bond, followed by consecutive loss of methyl radicals. The observed hydrocarbon products can be explained in terms of secondary reactions. Ethane is produced through recombination of two methyl radicals, while methane is produced from hydrogen abstraction of a methyl radical.

Scheme 10. Mechanism of decomposition of tetramethylgermane (**11**) (above 710 °C).<sup>24</sup>

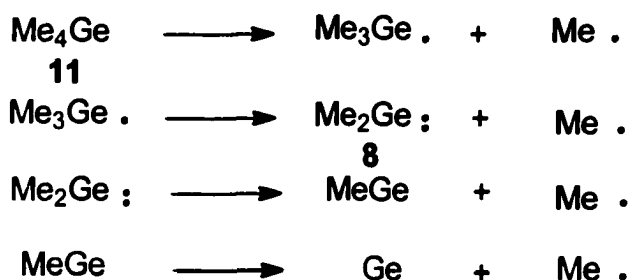

secondary reactions:

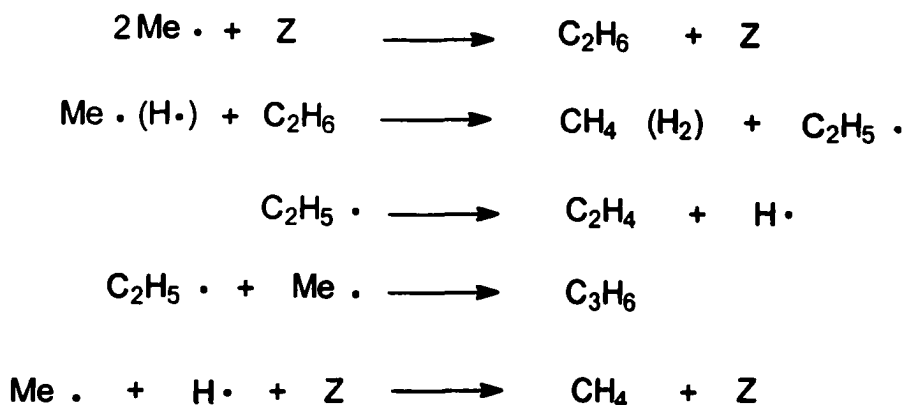

Ethylene is explained as being the result of decomposition of the ethyl radical to ethylene and a hydrogen atom. Propene, produced only in small amounts, is formed through recombination of methyl and ethyl radicals. Butane from ethyl radical recombination is not observed, although this is perhaps a consequence of

the relative abundance of methyl radicals and hydrogen atoms. It is clear from the kinetic data that another mechanism is operative below 710 °C.

The authors propose for this mechanism the geminate elimination of ethane from tetramethylgermane (11) followed by loss of methyl radicals from the resulting dimethylgermylene (8). The increase of the activation energy in the presence of surface effects is an unusual result. The increase was reported as being the result of a "semi-steady state" condition being developed between the deposited Ge metal on the surface and the tetramethylgermane in the gas phase. At higher temperatures Ge deposition would be aided by surface nucleation, but at lower temperatures the reverse reaction of methyl radicals with Ge would be of greater importance, increasing the observed activation energy of the reaction.

A later work on the pyrolysis and kinetics of thermal decomposition of tetramethylgermane (11) using a static system indicated a first order homogenous reaction.<sup>25</sup> The Arrhenius (measured by means of change in pressure, over the temperature range of 525-555 °C) parameters were reported as  $E_a = 68.9$  kcal/mol and  $\log A = 15.4$ . The gaseous products were reported to be mainly methane, ethane and hydrogen. The mechanism was thought to proceed through homolytic Ge-C cleavage; abstraction of hydrogen by the resulting methyl radical would produce the major product methane. The activation energy was close to the reported Ge-C bond strength (variously reported as being around 76-83 kcal/mol<sup>26-28</sup>) and was similar to the value measured by Taylor when under high temperature conditions.

### Ethylgermane (12) and Diethylgermane (13)

No kinetic studies on the thermal decomposition of ethylgermane(12) and diethylgermane (13) have been reported. CO<sub>2</sub> laser induced decomposition studies were carried out on these compounds,<sup>29</sup> Scheme 11 shows the products of the decompositions. The mechanism of the reactions was not speculated on in detail, but rather said to be analogous to that of methylgermane (3).

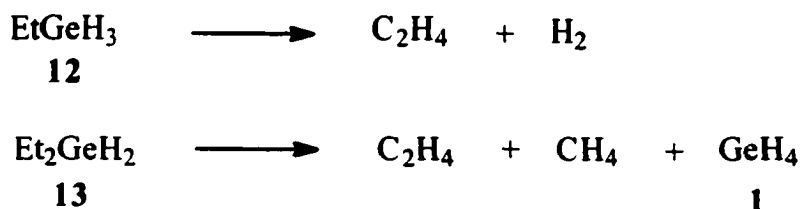
Scheme 11. Products of CO<sub>2</sub> induced decomposition of **12** and **13**.<sup>30</sup>

Thus, three primary modes of decomposition would occur: the concerted elimination of hydrogen from germanium, the geminate elimination of ethane, and the four-center elimination of hydrogen, forming a germene. In addition, a fourth process of decomposition is available in ethylgermanes: the  $\beta$ -elimination of ethylene.

#### Triethylgermane (14)

Mazerolles reported the thermal decomposition of triethylgermane (**14**) as producing ethylene and hydrogen in a flow system.<sup>31</sup> The reaction was similar to the decomposition of tetraethylgermane (**15**), but decomposition began 100 °C lower (decomposition range studied was from 300-600 °C) than that of tetraethylgermane (**15**). The mechanism was proposed to be consecutive homolytic cleavage of Et-Ge bonds, with ethylene being the result of decomposition of an ethyl radical through loss of a hydrogen atom. The resulting germyl radicals would abstract hydrogen atoms, eventually giving germane itself which would then decompose by loss of H<sub>2</sub>, finally giving germanium metal.

The later work of Harrison and Torr<sup>32</sup> further examined the thermolysis of triethylgermane (**14**) in static reaction vessels monitored by FT-IR spectroscopy. The products were reported to be ethylene, ethane, and diethylgermane (**13**) at 93% conversion (see Table 7, conditions were 380 °C for 2000 seconds). Hydrogen could not be detected under the experimental conditions.

Kinetics measured by the loss of triethylgermane (**14**) over time (over the temperature range of 628-653 K) gave second-order kinetics. The Arrhenius parameters were given as  $E_a = 72$  kcal/mol,  $\log A = 25$ ). The reaction, when carried out in the presence of methyl iodide (4:1  $\text{Et}_3\text{GeH}/\text{MeI}$ ) as a radical initiator was found to increase the reaction rate, while in the presence of excess methyl iodide, the reaction was first-order. The radical scavenger nitric oxide was

Table 7. Gaseous products of thermolysis of **14** at 380 °C for 2000 s.<sup>32</sup>

Component	Molar abundance/ $10^{-4}$ mol L <sup>-1</sup>	Mol product/mol $\text{Et}_3\text{GeH}$ reacted
triethylgermane ( <b>14</b> )	0.34	
diethylgermane ( <b>13</b> )	0.13	0.03
Ethane	6.21	1.38
Ethane	1.87	0.42

found to slow the reaction rate. No diethylgermane (**13**) was observed in the presence of nitric oxide or (4:1  $\text{Et}_3\text{GeH}/\text{MeI}$ ) methyl iodide. Based on the data, the mechanism of the decomposition was proposed to be a radical chain mechanism, shown in Scheme 12. The initiation step is that of the homolytic cleavage of a Ge-C bond, the Ge-H bond is about 5 kcal/mol stronger and so is not thought to be important in the decomposition. (The Ge-H bond strength reported as 83 kcal/mol<sup>33</sup>). Subsequent reactions involve abstraction of the germanium hydride by various radicals, followed by further loss of ethyl radicals through homolytic cleavage. The ethyl radicals decompose through loss of a hydrogen atom, giving ethylene. The  $\beta$ -elimination of ethylene was not considered, although it cannot be ruled out as a cooperative mechanism.

The formation of ethylene from ethyl radicals (through hydrogen atom loss) has Arrhenius parameters of  $E_a = 38-41$  kcal/mol, and  $\log A = 12.9-13.58$ <sup>34,35</sup> and can be expected to be a major route for loss of ethyl radicals under these conditions.

Scheme 12. Proposed mechanism of the thermolysis of triethylgermane (**14**).<sup>32</sup>

## Initiation

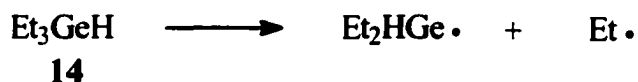

## Propagation

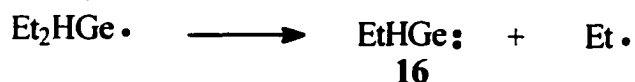
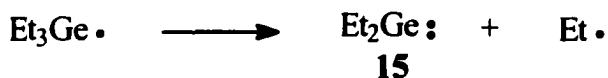
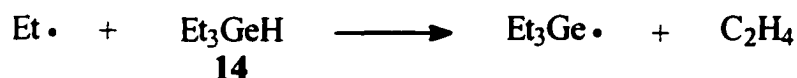

## Termination



Although not commented on by the authors, the recombination of ethyl radicals with hydrogen atoms, which are being generated in significant amounts, is most likely an additional source of ethane as well as the hydrogen abstraction from triethylgermane by ethyl radicals as shown in the propagation step. Deactivation is by the interaction of the reactor wall with a hydrogen atom



Scheme 13. Mechanism of diethylgermane (**13**) formation in the decomposition of **14**.<sup>32</sup>

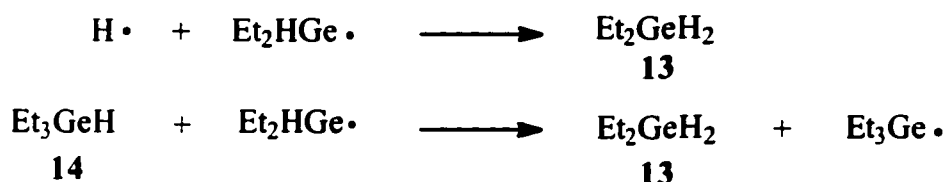

The observed diethylgermane (**13**), was proposed to be produced from the recombination of a hydrogen atom and germyl radical, or through hydrogen abstraction of the germyl radical as shown in Scheme 13. Not shown in Scheme 13 is the possible  $\beta$ -elimination of ethylene to directly give diethylgermane (**13**) which cannot be ruled out.

#### Tetraethylgermane (**17**)

The first kinetic study of the thermal decomposition of tetraethylgermane (**17**) was carried out by Mack in 1930.<sup>36</sup> The kinetics of the decomposition were measured by the change in pressure in a static reaction vessel over the temperature range of 420–450 °C. The gaseous products of the reaction were mainly ethylene (approximately 30% of volatiles), ethane (also approximately 30%), hydrogen (approximately 11%), methane (approximately 10%), propane (approximately 10%), and higher olefins (around 10%). The energy of activation was measured as 51 kcal/mol, while the log A was 14.3. The reaction was 98% homogenous. Although the mechanism of the decomposition was not discussed in detail, the authors proposed that the primary reaction was the loss of free ethyl groups. These free ethyl groups would combine to form butane, which would decompose to the observed products. The pyrolysis of butane was found to yield the same products as observed in the experiment.<sup>37</sup>

The decomposition of tetraethylgermane (17) was further examined in 1978 and a mechanism was proposed based on an analysis of the products.<sup>38</sup> The thermolysis experiments were carried out in semi-flow and static systems and the gaseous products analyzed by gas chromatography. Surface effects were examined by including 10 cm<sup>3</sup> of solid carrier carrier consisting of either glass or activated charcoal.

Table 8. Gaseous products from the thermal decomposition of tetraethylgermane (17), at 450 C° for 6 h.<sup>38</sup>

Solid Carrier	Product composition (mol%)								H <sub>2</sub> /C ratio	
	H <sub>2</sub>	CH <sub>4</sub>	C <sub>2</sub> H <sub>6</sub>	C <sub>2</sub> H <sub>4</sub>	C <sub>3</sub> H <sub>8</sub>	C <sub>3</sub> H <sub>6</sub>	C <sub>4</sub> H <sub>10</sub>	C <sub>4</sub> H <sub>8</sub>	Theo	Exptl.
Static system										
Glass	75.2	1.8	11.3	5.7	1.6	1.5	2.4	0.5	1.25	2.63
Char.	55.7	18.7	25.1	-	0.5	-	-	-	1.25	2.42
Semi-flow system										
Glass	8.6	16.8	9.6	72.2	-	1.3	1.5	-	1.25	1.20
Char.	87.8	2.1	2.3	7.0	0.1	0.7	-	-	1.25	4.99

The static experiments, performed at 450 °C for 6 hours showed a large amount of hydrocarbon cracking, with H<sub>2</sub> being the predominant gaseous product. The charcoal carrier generally served to catalyze the secondary hydrocarbon cracking reactions, as evidenced by the large amount of hydrogen produced on that carrier even under semi-flow conditions. Because of these secondary reactions it is hard to evaluate the actual effects of the surface on the primary decomposition modes of tetraethylgermane.

Experiments run at shorter times where the secondary hydrocarbon decomposition reactions are limited show the major products are ethylene and ethane, as well as hydrogen.



The flow thermolysis experiments of Mazerolles<sup>31</sup> using tetraethylgermane (17) showed similar results, although only ethylene and hydrogen were produced. No evidence for ethylgermanium hydrides was reported. A mechanism similar to that reported below<sup>38</sup> was proposed (Scheme 14).

The later work of Morancho and coworkers suggest the possibility of the  $\beta$ -elimination of ethylene being involved in the thermal decomposition of tetraethylgermane (17).<sup>39</sup> A horizontal cold-wall reactor at atmospheric pressure was utilized in metal organic chemical vapor deposition (MOCVD) experiments using tetraethylgermane (17) as a precursor over the temperature range of 500-560 °C. The reaction was found to be homogenous, with no change in rate due to changes in the surface to volume ratio. Experiments were conducted using either He or H<sub>2</sub> as a carrier gas, with marked differences were observed in the presence of H<sub>2</sub>. The main products under He flow were hydrogen and ethylene. The products with H<sub>2</sub> as a carrier were ethylene and ethane (Scheme 15).

Scheme 15. Gaseous products in the MOCVD of tetraethylgermane (17).<sup>39</sup>

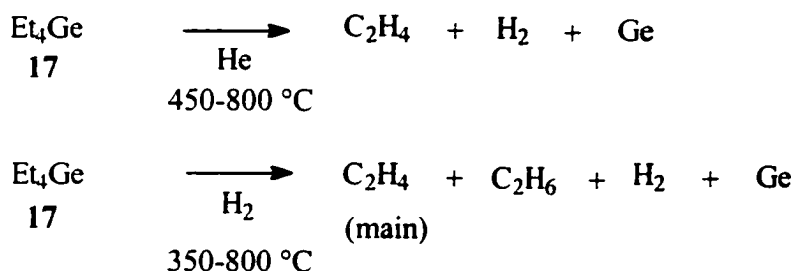

Indeed, the amount of ethane produced was dependant on the temperature, so that at higher temperatures, above 700 °C, ethane was the major product. In addition, the rate at which decomposition was first observed was lowered and the rate of decomposition increased in the presence of H<sub>2</sub>. The presence of the radical scavenger toluene (0.2% Et<sub>4</sub>Ge, 5% toluene in He) in the reaction did not affect the product distribution over the temperature range of 450-800 °C, suggesting that ethyl radicals were not involved in the decomposition under the reaction conditions. The absence of ethyl radicals was further supported by the results of recombination

experiments with Pb thin films. In the experiment a film of tin is first deposited in a flow system using  $\text{PbEt}_4/\text{He}$  as a precursor. Next the heated zone is moved upstream so the film is just outside the exit of the heated zone. The precursor is then re-introduced. In the case of  $\text{PbEt}_4$  the resulting ethyl radicals etch away the tin film at the end of the reactor zone. After the system was optimized, the introduction of tetraethylgermane caused no etching of the tin film, implying an absence of ethyl radicals.

The thermolysis of tetraethylgermane (17) with  $\text{D}_2$  as a carrier gas was carried out. No evidence for partial deuteration of hydrocarbons was observed, instead only  $\text{C}_2\text{D}_4$  and  $\text{C}_2\text{D}_6$  were observed. This possibly is the result of rapid exchange reactions between  $\text{C}_2\text{H}_4$  and  $\text{D}_2$ , with  $\text{C}_2\text{D}_6$  being formed through deuteration of  $\text{C}_2\text{D}_4$ . In any case, the formation of  $\text{C}_2\text{H}_6$  was found to be the result of hydrogenation of ethylene: a mixture of  $\text{H}_2/\text{C}_2\text{H}_4$  was introduced into the reactor and  $\text{C}_2\text{H}_6$  was formed.

The results here are different than previous literature reports, which could be explained by the fact that most of the previous work was done under static conditions where secondary reactions may effect product distributions. Clearly, the results above do not show any presence of radicals under flow conditions. Instead, a  $\beta$ -hydrogen elimination mechanism was proposed for the decomposition mechanism of tetraethylgermane.

### Other tetraalkylgermanes

The thermolysis of other tetraalkylgermanes have also been studied, and not surprisingly, the thermal behavior is essentially the same as that of tetraethylgermane (17). Tables 10 and 11 show the composition of the gaseous products from the thermal decomposition of tetrapropylgermane (18) and tetrabutylgermane (19) respectively.

Table 10. Gaseous products from the thermal decomposition of tetrapropylgermane (**18**) in a semi-flow system on 10 cm<sup>3</sup> activated charcoal solid carrier.<sup>38</sup>

Time	T °C	Product composition (mol%)							H <sub>2</sub> /C ratio	
		H <sub>2</sub>	CH <sub>4</sub>	C <sub>2</sub> H <sub>6</sub>	C <sub>2</sub> H <sub>4</sub>	C <sub>3</sub> H <sub>8</sub>	C <sub>3</sub> H <sub>6</sub>	C <sub>6</sub> H <sub>14</sub>	Theo.	Exptl.
3hr	450	24.8	6.8	1.0	0.8	8.3	22.2	1.1	1.16	1.6
3min	450	27.0				9.4	63.6		1.16	1.6

The observed major products of tetrapropylgermane (**18**) are propene, propane and hydrogen. In the case of longer reaction times other hydrocarbons are formed due to secondary reactions of the propyl radical. The decomposition of **18** is entirely analogous to that of tetraethylgermane, and the authors proposed an identical mechanism (consecutive homolytic cleavage of the Ge-C bond, followed by hydrogen abstraction to give propene and a propylgermane<sup>38</sup>) to describe its decomposition (see Scheme 11). No germanium hydrides were observed in these experiments.

Tetrabutylgermane (**19**) was also studied under the same conditions. The product distribution is shown in Table 11 below. At a reaction time of three minutes the major products of the thermal decomposition of **19** are butene, butane, and hydrogen.

Table 11. Gaseous products from the thermal decomposition of tetrabutylgermane (**19**) in a semi-flow system on 10 cm<sup>3</sup> activated charcoal solid carrier.<sup>38</sup>

Time	T °C	Product composition (mol%)							H <sub>2</sub> /C ratio	
		H <sub>2</sub>	CH <sub>4</sub>	C <sub>2</sub> H <sub>4</sub>	C <sub>3</sub> H <sub>8</sub>	C <sub>3</sub> H <sub>6</sub>	C <sub>4</sub> H <sub>10</sub>	C <sub>4</sub> H <sub>8</sub>	Theo.	Exptl.
3hr	450	93.0	2.6	0.4	0.6	0.1	0.9	1.3	1.12	5.7
3min	450	24.0	-	-	-	-	14.0	62.0	1.12	1.125

Longer reaction times result in almost complete decomposition of the primary products into other hydrocarbons. The author proposed a mechanism identical to that for tetraethylgermane (see Scheme 11) for the decomposition of **19**. No germanium hydrides were observed in these experiments. The isomeric composition of butene (i.e. 1-butene and 2-butene) was not reported.

## Results and Discussion

In Chapter 1, the poor trapping behavior of dibutylgermylene (**20**) generated from 1,1-dibutylgermacyclopent-3-ene (**21**) was discussed. In an SFR system the dibutylgermylene (**20**) generated from germacyclopentene **21** in the presence of 60 molar excess 2,3-dimethyl-1,3-butadiene was "trapable" (no loss of material) up to 450 °C (approximately 35% decomposition). At higher percent conversion, the amount of trapped germylene remained constant up to 475 °C, after which the amount of trapped material declined. This is unusual since the trapping of germylenes by 1,3-butadienes is usually very efficient.<sup>40</sup> Flow pyrolysis experiments revealed that the trapped product was in fact not the expected 1,1-dibutyl-3,4-dimethylgermacyclopent-3-ene (**22**), but instead the products of the formal addition of two molecules of 2,3-dimethyl-1,3-butadiene to germanium **23** and **24**. No trapping of the intermediate dibutylgermylene (**20**) occurred at all!

Scheme 16. Trapping products in the thermal decomposition of 1,1-dibutyl-1-germacyclopent-3-ene (**21**).

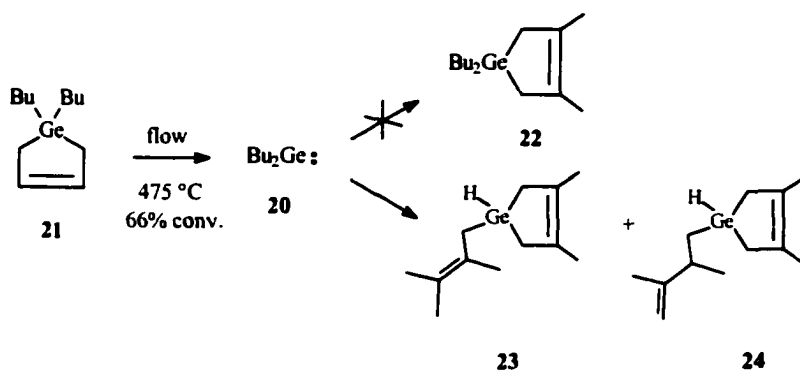

A review of the literature found few references to di-*n*-alkylgermylene formation in the gas phase, only a few studies that mainly dealt with matrix isolation and spectroscopic analysis of di-*n*-alkylgermylenes generated photochemically.<sup>41,42</sup>

One study proposed diethylgermylene as a reactive intermediate in the static thermolysis (230-250 °C) of chloropentaethyldigermane **26** (Scheme 17).<sup>43</sup> The products of the reaction were triethylchlorogermane (**25**), chloroheptaethyltrigermane **27**, and chlorononaethyltetragermane **28**. The tetragermane **28** appeared only after conversion was greater than 50%.

Scheme 17. Static pyrolysis of pentaethylchlorodigermane **26**.<sup>43</sup>

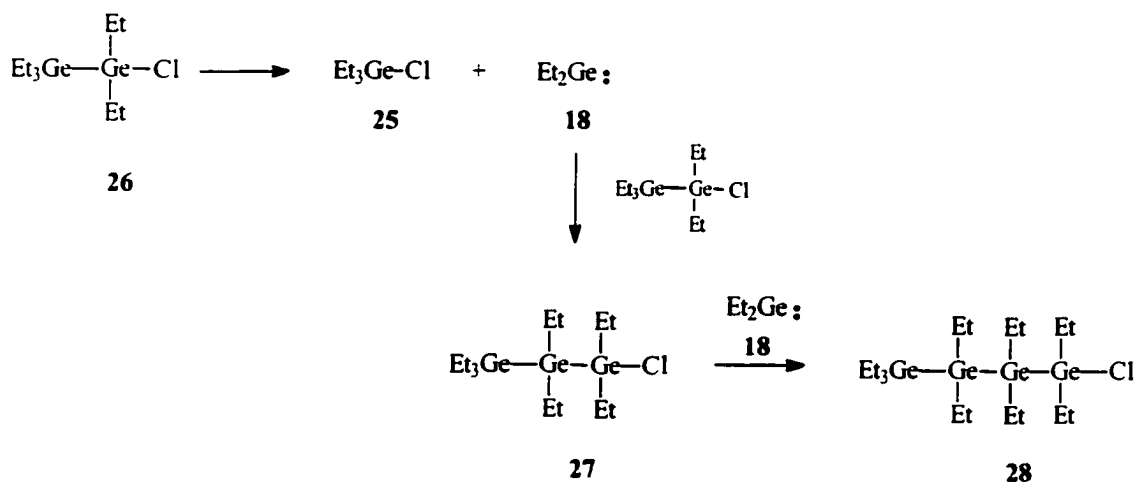

The proposed mechanism was a 1,2-chlorine shift, giving the observed triethylgermane (**25**) and diethylgermylene (**18**), which then inserted into a Ge-Cl bond of the starting material (or into that of the trigermane **27**) giving the observed products. It was reported that attempts to trap the intermediate with tolane were unsuccessful, insertion into a Ge-Cl bond being preferred.

The silicon analog, hexylsilylene produced through thermolysis of hexylsilane, had been studied and found to undergo intramolecular reactions in the gas phase that were much faster than even trapping with 1,3-butadienes.<sup>44</sup> In the pyrolysis of



the labeled hexylsilane-d<sub>3</sub> (**29D**), labeled hexenes were produced, with the greatest deuterium incorporation being in the 2-hexene and 3-hexene isomers (Scheme 18). Deuterium NMR showed that the label was mainly on 2- and 3-position of 1-hexene, and the 2- and 3-positions of 2-hexene.

Scheme 18. Pyrolysis and mechanism of hexylsilane-d<sub>3</sub> (**29D**).<sup>44</sup>

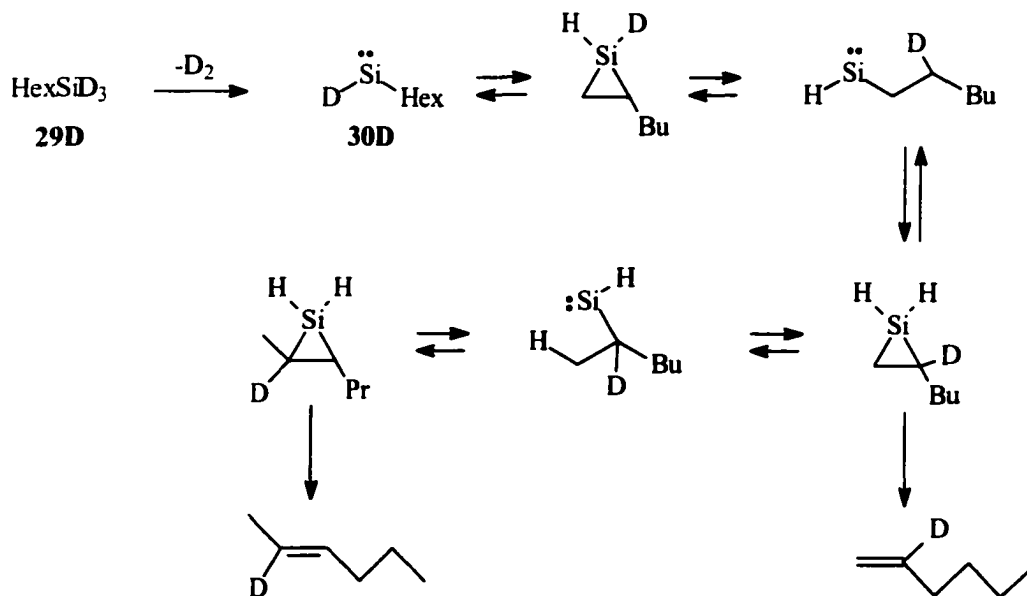
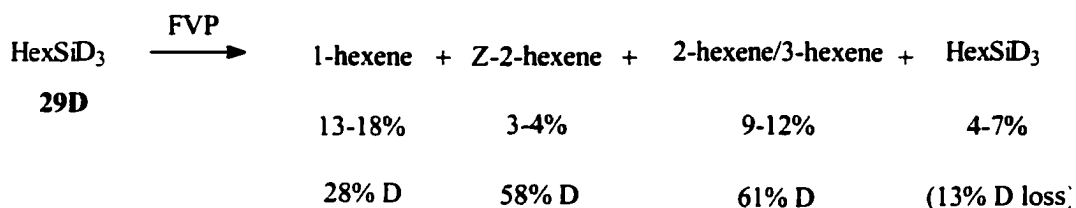

The initial decomposition of hexylsilane-d<sub>3</sub> (**29D**) is through loss of hydrogen, giving the labeled hexylsilylene **30D**. The proposed mechanism of deuterium incorporation is through C-H insertion to form a silirane, followed by a 1,2-shift of deuterium, regenerating the hexylsilylene, now with deuterium incorporated into the alkyl residue. The loss of hexane from the intermediate silylenes gives the labeled

hexenes. The intramolecular process of silylene insertion into a C-H bond of the alkyl group was so fast that no intermediate hexylsilylene could be trapped. If dibutylgermylene (**20**) behaves like the hexylsilylene above, then it could undergo a very fast intramolecular  $\beta$  C-H insertion to form a germirane.

Scheme 19. Proposed decomposition of dibutylgermylene (**20**)

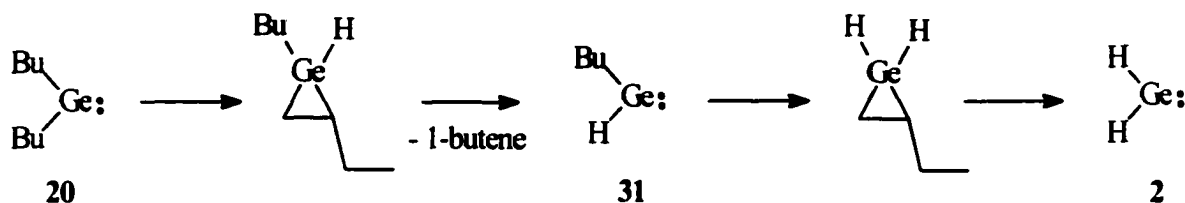

The germirane easily decomposes to an alkene and an *n*-butylgermylene (**31**). The remaining *n*-butyl group can be eliminated in the same manner, leaving germylene (**2**). The germylenes thus produced (particularly **2**) may also be trapped but are likely to be unstable under the conditions of the thermolysis.

There are few known cases of germylene insertion into a C-H bond. Perhaps the best example of such insertion is in the gas phase pyrolysis of methylbis-(trimethylsilyl)germane (**32**).<sup>45</sup>

Scheme 20. Decomposition of methyl(trimethylsilyl)germylene (**33**) and C-H insertion.<sup>45</sup>

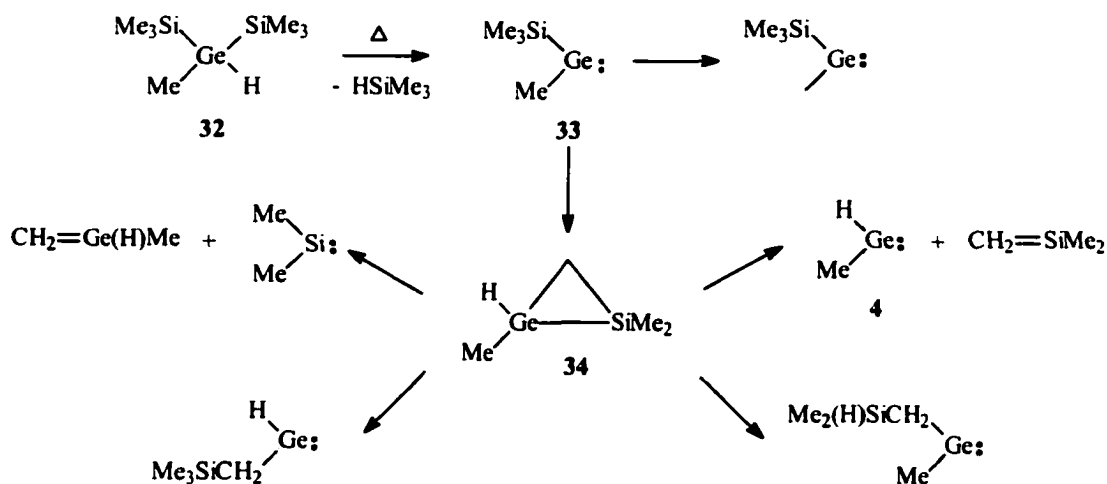

The initial loss of trimethylsilane yields the methyl(trimethylsilyl)germylene (**33**). In the presence of 2,3-dimethyl-1,3-butadiene, the expected trapping product was observed, but in addition a variety of other products were produced. The products were consistent with the intermediacy of silagermirane **34** formed through the insertion of germylene into a C-H bond of the trimethylsilyl group. The fragmentation and rearrangements of the silagermirane **34** gave intermediates that were evident from their trapping products with 2,3-dimethyl-1,3-butadiene (Scheme 20).

Another example of germylene insertion into a C-H bond is the solution reaction of di(2,4,6-tri-*t*-butylphenyl)germylene (**35**), which at room temperature undergoes intramolecular C-H insertion into an adjacent *t*-butyl group to give a cyclized product **36** (Scheme 21).<sup>46</sup>

Scheme 21. Intramolecular C-H insertion of germylene **35**.<sup>46</sup>

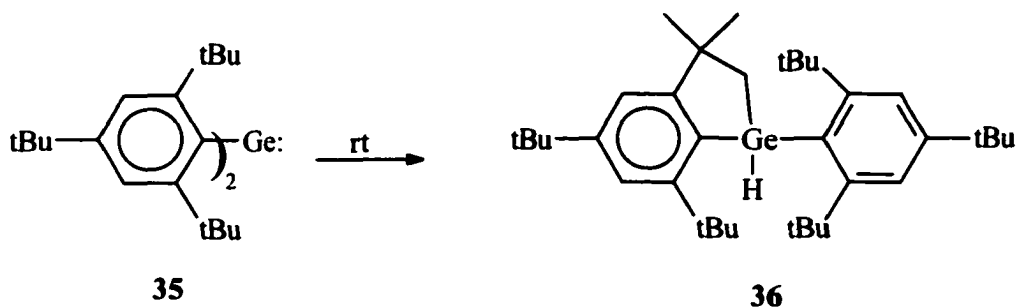

To test the mechanism of decomposition of dialkylgermylenes proposed above (Scheme 19), several precursors were made. The precursors were designed to decompose to dialkylgermylenes through well known thermal processes. The thermal routes to germylene that were employed are shown in Scheme 22. The first is the well known extrusion of germylene from germacyclopentene **37**,<sup>40</sup> which proceeds through a 1,3-germyl shift to a germirane, followed by elimination to give the desired germylene. The efficient method of germylene generation through geminate elimination of trimethylsilane, used by Gaspar above,<sup>45</sup> was also used. This method has the advantage of being a relatively low temperature process. The

last method, the thermolysis of alkylgermanes, has been shown to produce germynes, however, the mechanism is more complex than the previous two routes, and may have other process occurring. Methylgermane (3), for example was proposed to have two routes of decomposition apart from loss of H<sub>2</sub> shown below, one of which is molecular elimination of methane, the other was the four-center elimination of H<sub>2</sub> to give a germene.<sup>16</sup> However, this germene would most likely rearrange to a gerylene under high temperature conditions since the barrier for isomerization was calculated (for the germene to methylgermylene isomerization) to be 33.1 kcal/mol.<sup>47</sup>

Scheme 22. Thermal routes to germynes.

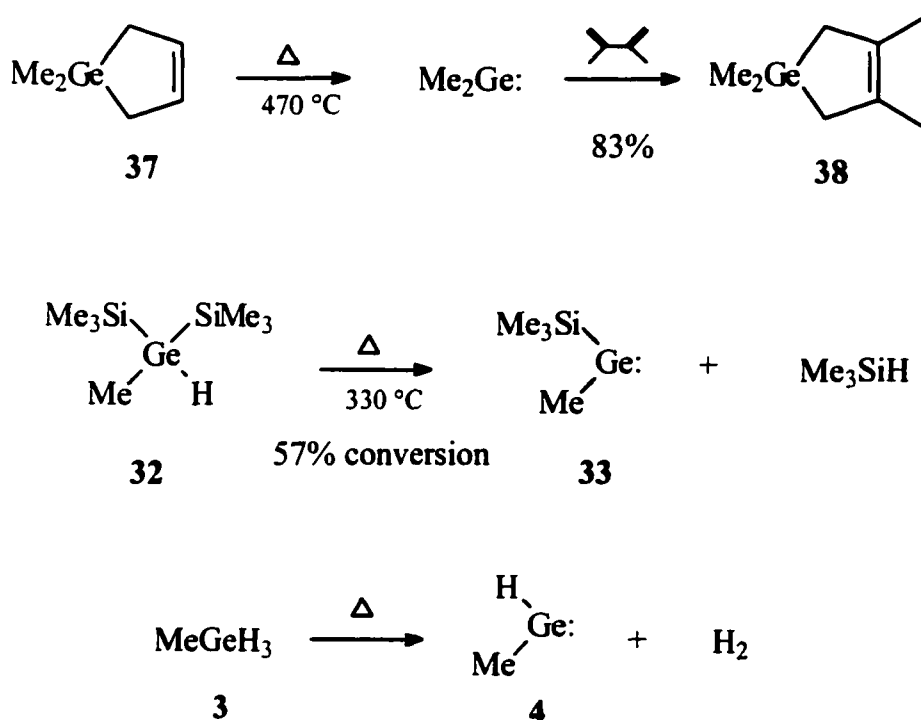

The precursors were synthesized mainly through literature routes. The dihexylgermacyclopentenes **40** and **41** were made through the reaction of germanium diiodide (**39**) and the appropriate diene in a sealed vessel at 60 °C for 4 hours.<sup>48</sup> The resulting diiodide was then treated with hexyl Grignard reagent to obtain the desired products in >85% yield.

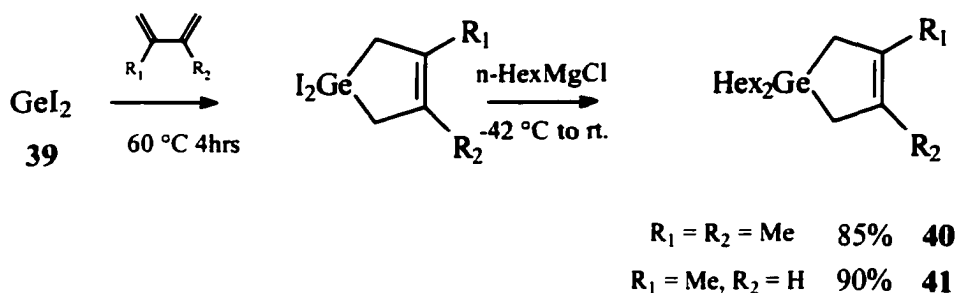
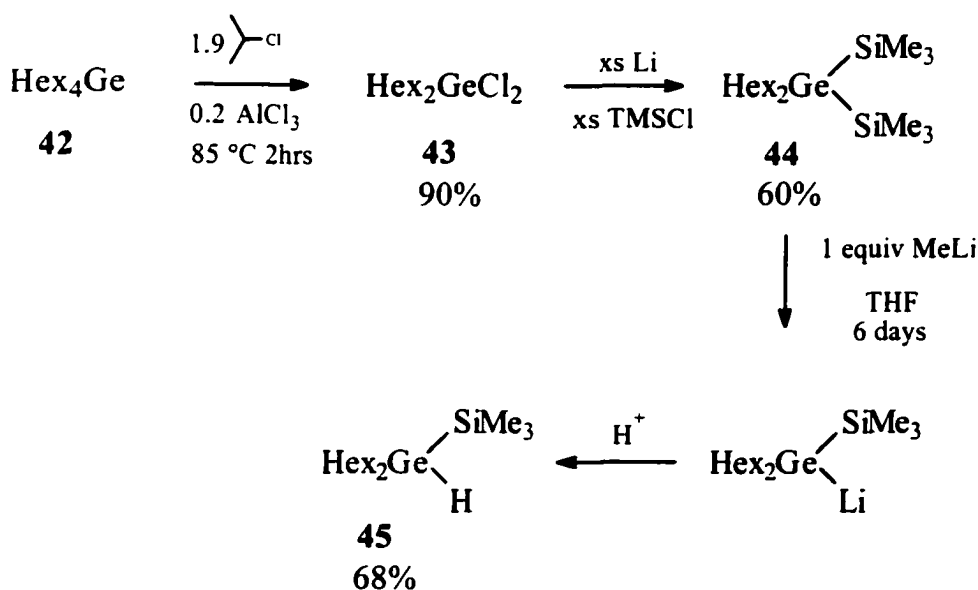
Scheme 23. Synthesis of dihexylgermacyclopentenes **40** and **41**.Scheme 24. Synthesis of dihexyl(trimethylsilyl)germane (**45**).

The precursor dihexyl(trimethylsilyl)germane (**45**) was made as shown in Scheme 24. Dihexyldichlorogermane (**43**) was made by a modification of the redistribution reaction of Mironov,<sup>49</sup> utilizing 1.9 equivalents of 2-chloropropane and 0.2 equivalents of aluminum chloride. The reaction, performed neat at 80 °C under argon, provided the desired product in 90% yield. Next, the lithium coupling with trimethylsilyl chloride was carried out, giving dihexylbis(trimethylsilyl)germane (**44**) in 60% yield. The lithiation of this compound with methyl lithium was quite slow, taking 6 days to reach complete conversion. Upon work-up, the desired precursor **45** was obtained in 68% yield.

Scheme 25. Synthesis of dihexylgermanes **49** and **49D** and hexylgermanes **48** and **48D**.

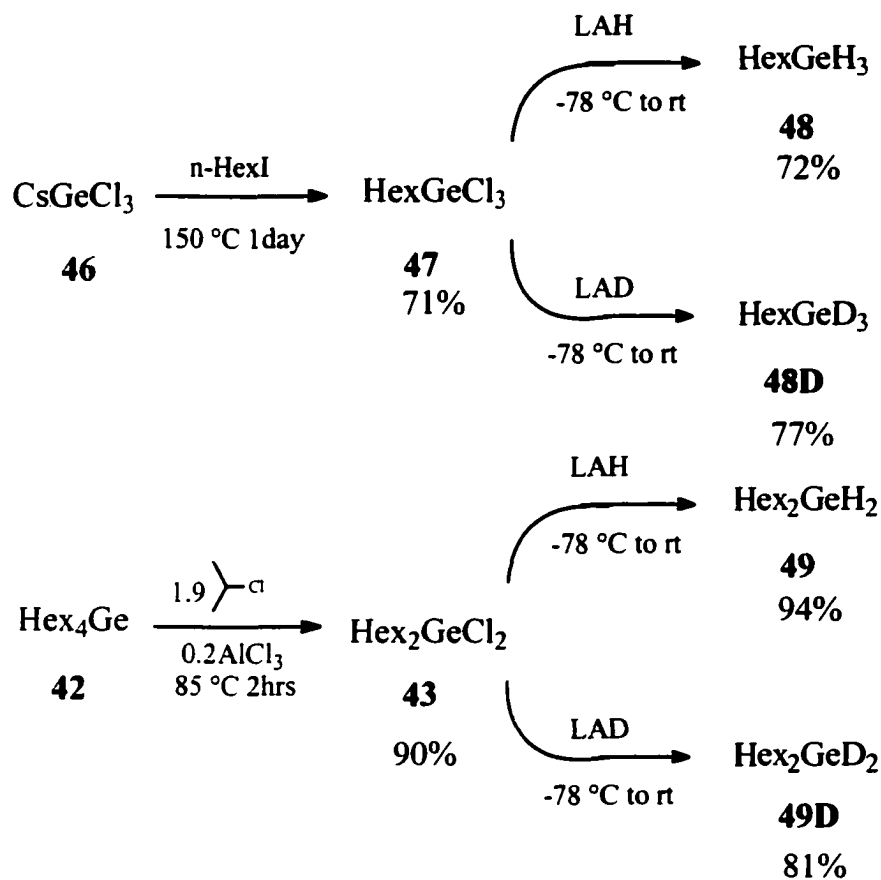

A series of hexylgermanes were also synthesized through reduction of the appropriate germyl chloride with either lithium aluminum hydride or lithium aluminum deuteride (Scheme 25). Hexyltrichlorogermane (**47**) was made through the reaction of cesium trichlorogermanate (**46**) and *n*-hexyl iodide at 150 °C for 1 day, giving 71% yield. Trihexylchlorogermane (**50**) was made through two methods, with the second method being preferred. In the first route, the unmodified method of Mironov was used, which provided the product in moderate yield, but lacked specificity (the reaction produced small amounts of dihexyldichlorogermane (**43**)). The better route was through the redistribution reaction of tetrahexylgermane (**42**) and tin tetrachloride in refluxing nitromethane,<sup>50</sup> which gave a better yield with no side reactions (Scheme 26).

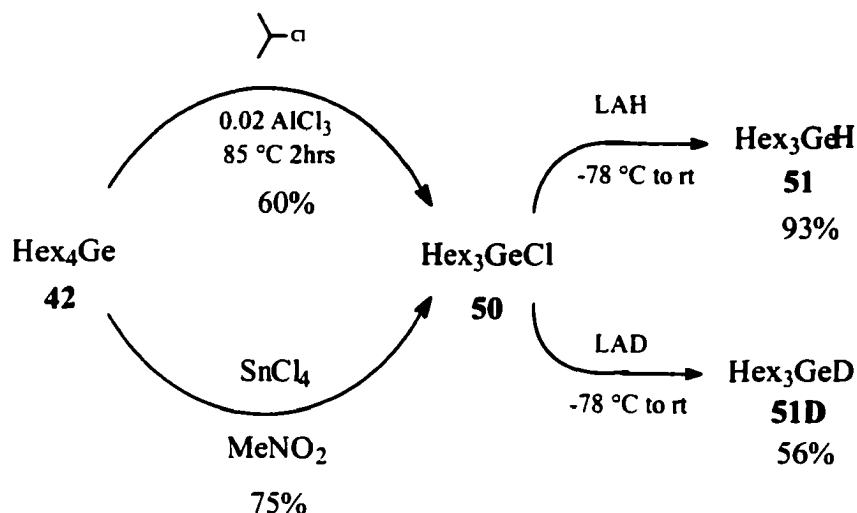
Scheme 26. Synthesis of trihexylgermanes **51** and **51D**.

The first pyrolyses were carried out on hexylgermane (**48**) and hexylgermane- $\text{d}_3$  (**48D**) in a flash vacuum pyrolysis apparatus (FVP) at 470-490 °C. The results are shown in Scheme 27. The major product observed by GC-MS analysis was 1-hexene, with 2-hexene, 3-hexene and hexane being very minor products. In addition a number of other volatile hydrocarbons were formed which indicated that secondary reactions, perhaps chain radical reactions, were present

The analysis of the deuterium incorporation in hexenes produced from the pyrolysis of **48D** showed mostly monodeuteration, although some dideuteration (3-10% of the total amount of deuterated species depending on the isomer) occurred. No loss of labeling was observed in the recovered starting material. However, the presence of secondary reaction products precludes any mechanistic speculation based on a careful examination of the pyrolysis products. Therefore, all subsequent pyrolysis were undertaken under flow pyrolysis conditions in the presence of toluene (or other hydrocarbon), which served to limit secondary reactions.

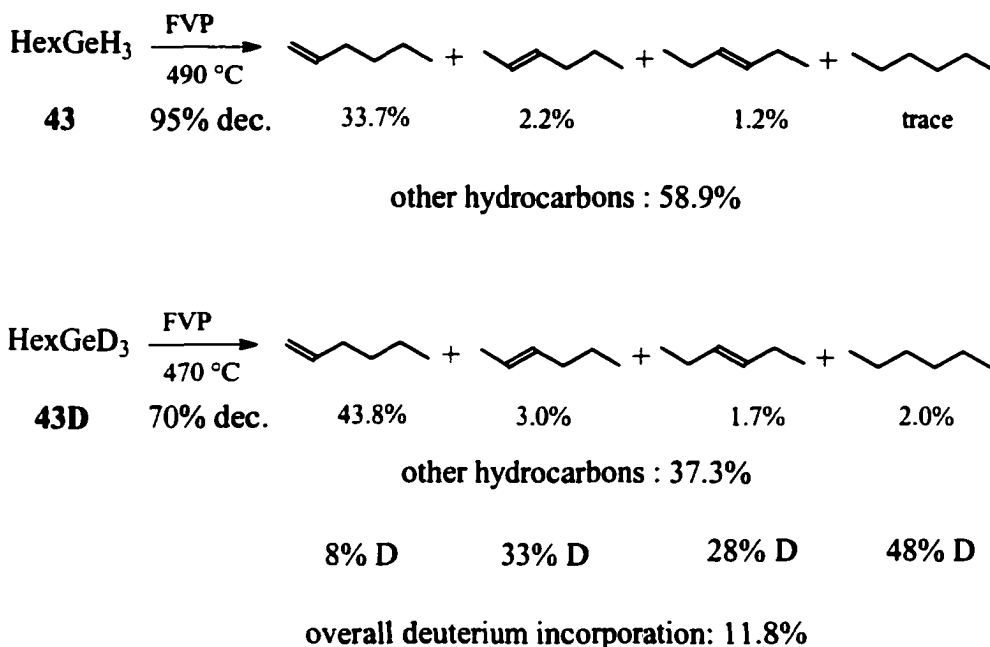
Scheme 27. FVP of hexylgermane (**48**) and hexylgermane (**48D**).

Flow pyrolysis experiments on the synthesized precursors are summarized in Table 12. Yields are absolute, determined by GC techniques using internal standards. Flow pyrolysis of the substrates was performed in a 50 cm quartz chip-packed, vertical quartz tube, with a flow rate of 60 mL/min of Helium. The reactor surfaces were germanium coated through the chemical vapor deposition of tetraalkylgermane precursors. Surface effects are evident when the results are compared to the same experiments performed over a silica surface. The surface effects will be discussed in detail later, for the present discussion the results reported are confined to those pyrolysis carried out over a germanium surface.

Note also that all kinetic measurements were performed using germanium coated reactors, although surface effects here are not expected because the SFR is essentially a wall-less reactor. The precursors were introduced into the column in solution (usually around 0.12-0.2 M concentration) and the pyrolysate trapped in a receiving flask cooled to  $-78\text{ }^\circ\text{C}$  (2-propanol/dry ice) or  $-116\text{ }^\circ\text{C}$  (ethanol/ $\text{N}_2$ ).

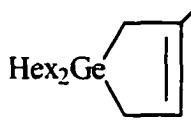
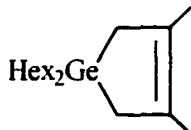
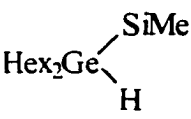

Table 12. Products of the flow pyrolysis of dihexylgermylene precursors over a germanium surface.

Substrate	T (°C)	Conv (%)	Products (% yield)				
			1-hexene	2-hexene	3-hexene	C <sub>6</sub> H <sub>14</sub>	Other
 <b>41</b>	450	85	32	51	17	-	C <sub>5</sub> H <sub>8</sub> 37
 <b>40</b>	450	65	25	54.5	20	-	25
 <b>45</b>	300	66	65	25	10	-	TMS. 28
HexGeH <sub>3</sub> <b>48</b>	400	84	69	15	7	10	
Hex <sub>2</sub> GeH <sub>2</sub> <b>49</b>	410	97.4	60	22.5	12	6	
Hex <sub>3</sub> GeH <b>51</b>	450	55	55	26	14	5	
Hex <sub>4</sub> Ge <b>42</b>	560	60	35	35	19	11	

It should be noted that in independent experiments, hexenes did not isomerize under the conditions used in these thermolyses.

In all the precursors studied, the major products of the pyrolysis were 1-hexene, *trans*-2-hexene, and *trans*-3-hexene (determined by GC-MS comparison to known compounds). The product 1-hexene predominated except for in the cases of dihexylgermacyclo-pentenes **40** and **41**. Both compounds produced 2-hexene as the major isomer.

Scheme 28. Proposed mechanism for the decomposition of dihexylgermylene (**52**) through consecutive C-H insertion and elimination.

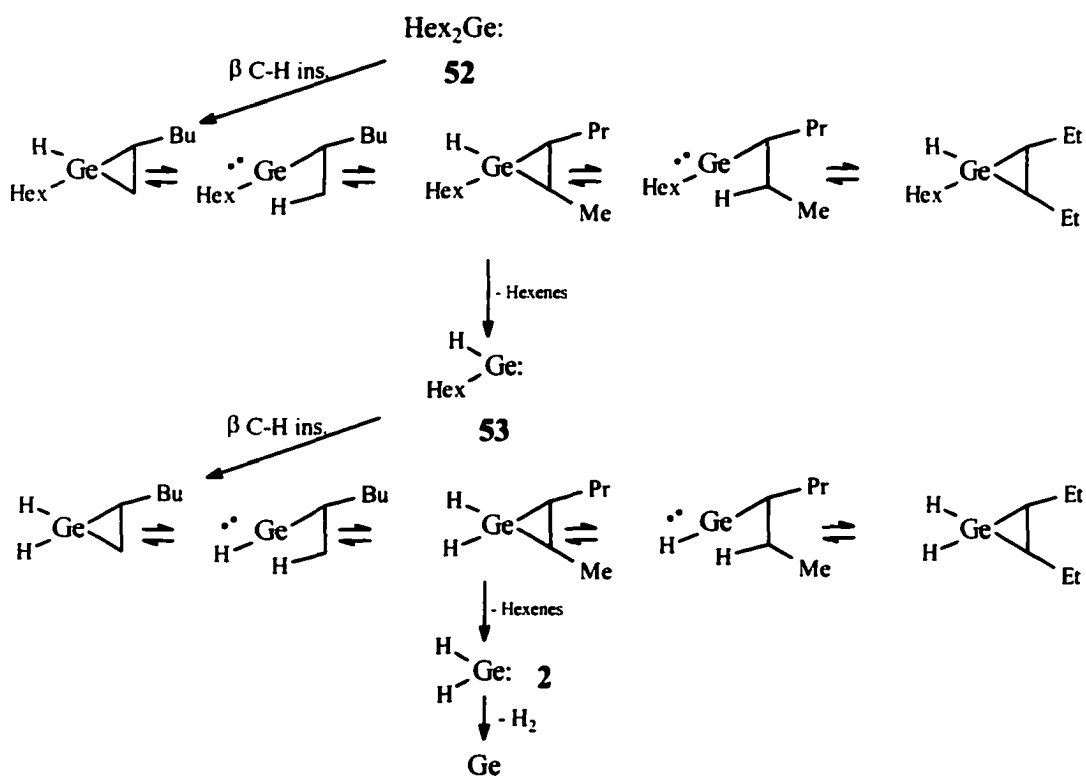

Hexane was only produced in the pyrolysis of the hexylgermanes **48**, **49**, **51**, and **42**. The production of hexane is a consequence of the different routes of decomposition available to the hexylgermane precursors prior to dihexylgermylene formation. The germacyclopentene **41** and trimethylsilylgermane **45** precursors form the dihexylgermylene (**52**) as the primary (and rate-determining step), and the

resulting products are consistent with the proposed mechanism (Scheme 28) of consecutive  $\beta$  C-H insertion followed by a 1,2-H shift. Hexenes are produced by elimination from the intermediate germiranes.

The differences in product distribution between **40** and **41**, which produce 2-hexene as the major isomer, and **45**, which produces 1-hexene as the major isomer, is interesting since dihexylgermylene (**52**) is produced in primary decomposition pathway in these cases. This behavior can be explained based on the mechanism in Scheme 29.

Scheme 29. Kinetics of product distribution of the pyrolysis of **40**, **41**, and **45**.

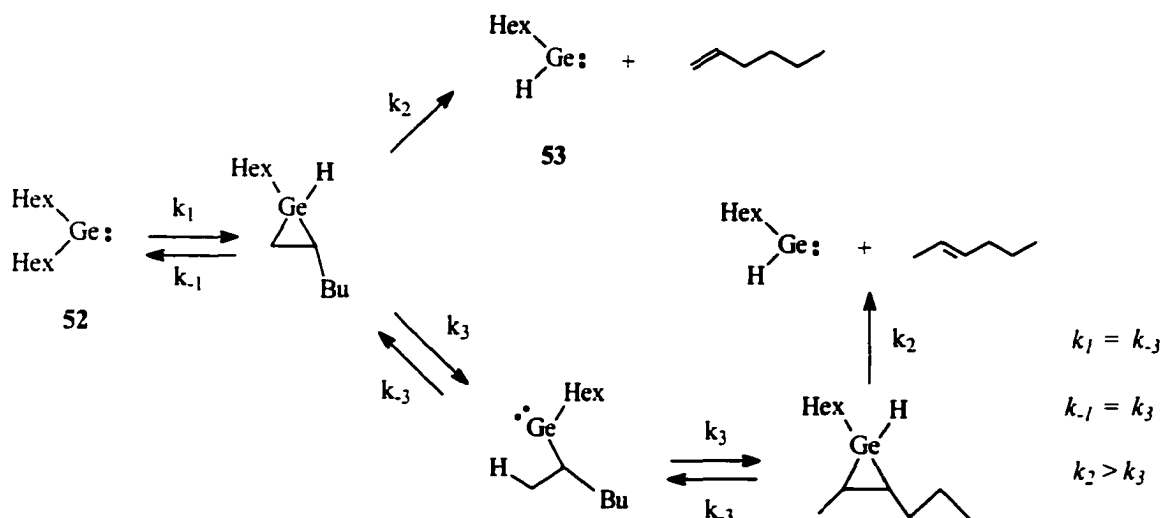

The mechanism shows that the ratio of 1-hexene to 2-hexene depends on the relative rates of  $k_2$  and  $k_3$ . These rates are not known. However, if the difference in activation energy of germirane decomposition and the 1,2-hydrogen shift was small enough, the processes could occur simultaneously. Unfortunately, the kinetics of the decomposition of germirane have not been studied because of its thermal instability, although highly substituted germiranes have been synthesized<sup>51</sup> the parent germirane has only been observed as a transient species.<sup>52</sup> Indeed, calculations of  $\Delta H^\circ$  for the decomposition reaction (germirane  $\rightarrow$   $\text{H}_2\text{Ge:} + \text{ethylene}$ ) of germirane indicate that it is even less stable than its silicon analog ( $\Delta H^\circ = 33$

kcal/mol for decomposition of germirane while for silirane  $\Delta H^\circ = 48$  kcal/mol).<sup>53</sup>

Thus, it is safe to assume that the barrier for extrusion of germylene from germirane is quite low, presumably lower than for a 1,2-hydrogen shift to occur. The pyrolysis of **45** is carried out at low temperature (300 °C), under these conditions the germirane formed from the initial  $\beta$  C-H insertion does not have enough energy to undergo a 1,2-hydrogen shift. Instead, the most favorable process is to extrude 1-hexene directly. At the higher temperatures necessary to form the dihexylgermylene from **40** and **41**, enough energy is present to allow the 1,2-H migration to occur freely, enabling germanium to migrate up and down the alkyl group. Elimination from the intermediate germiranes then gives a distribution of 1-hexene, 2-hexene (and 3-hexene).

In order to ensure that the formation of the dialkylgermylene was the rate-determining step in the decomposition, the kinetics of the decomposition of 1,1-diethyl-3,4-dimethyl-1-germacyclopent-3-ene (**72**) were measured. The kinetics of the formation of both ethylene and 2,3-dimethyl-1,3-butadiene were measured over the temperature range of 450-500 °C which produced 25-75% conversion (measured by loss of **72**, shown in Scheme 30).

Scheme 30. Kinetics of the formation of 2,3-dimethyl-1,3-butadiene and ethylene in the thermal decomposition of **72**.

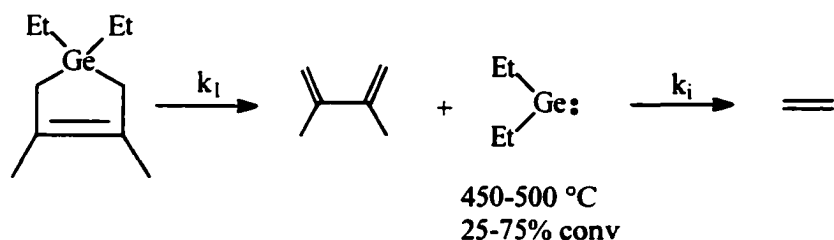

For 2,3-dimethyl-1,3-butadiene  
 $E_a = 47.4$  kcal/mol ( $\pm 0.5$ )  
 $\text{Log } A = 12.4$  ( $\pm 0.15$ )  
 $\Delta H^\ddagger = 45.8$  kcal/mol ( $\pm 0.5$ )  
 $\Delta S^\ddagger = -5.5$  cal / K mol ( $\pm 0.67$ )

For ethylene  
 $E_a = 48.0$  kcal/mol ( $\pm 0.5$ )  
 $\text{Log } A = 12.2$  ( $\pm 0.16$ )  
 $\Delta H^\ddagger = 46.5$  kcal/mol ( $\pm 0.54$ )  
 $\Delta S^\ddagger = -6.4$  cal / K mol ( $\pm 0.72$ )

The results give the Arrhenius parameters for the formation of 2,3-dimethyl-1,3-butadiene, which is formed by the initial extrusion of diethylgermylene, as  $E_a = 47.4$  kcal/mol and  $\log A$  of 12.4. The Arrhenius parameters for the formation of ethylene, formed presumably through consecutive intramolecular C-H insertion of the germylene and elimination, were  $E_a = 48.0$  kcal/mol and  $\log A = 12.2$ . These parameters are within experimental error and are essentially identical. The conclusion can only be that the rate-determining step of the decomposition of dialkylgermacyclopentenes is formation of the germylene. Not much can be learned from this experiment about the barrier for germylene insertion into a C-H bond other than it must be less than around 48 kcal/mol. Recent calculations<sup>54</sup> have shown that the barrier for insertion of dimethylgermylene into the C-H bond of methane is around 39 kcal/mol. Substituents would probably lower this value somewhat, but in any case it is lower than the observed activation energy.

Trapping studies utilizing isoprene and dihexyl(trimethylsilyl)germane (**45**) were carried out to attempt to demonstrate the presence of the germylenes **52** and **53** in the reaction.

Scheme 31. Trapping experiments with dihexyl(trimethylsilyl)germane (**45**) and isoprene.

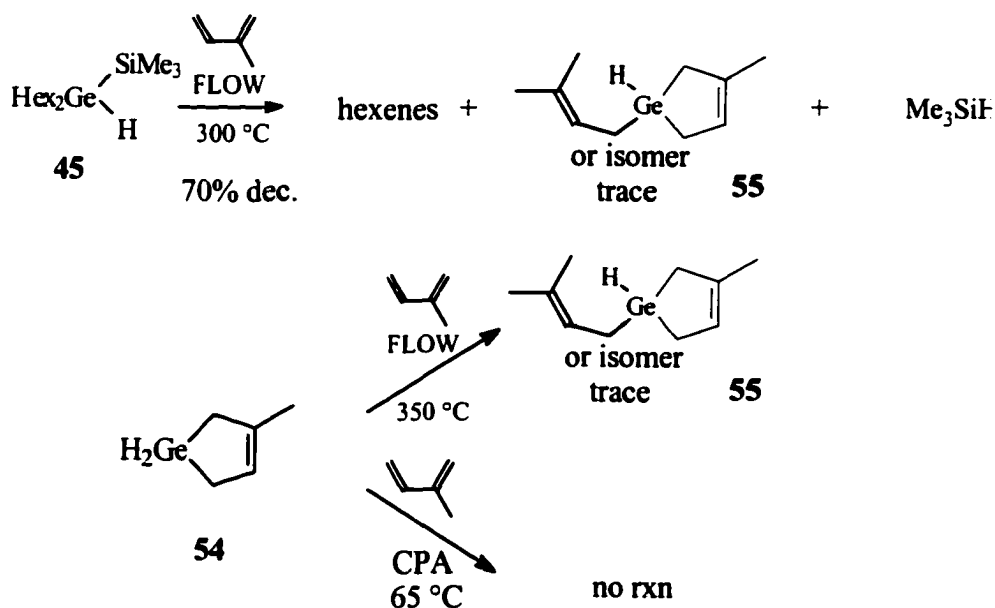

It was hoped that the lower temperatures required for this precursor would allow some of the trapped products to be observed. The results are shown in Scheme 31. As expected, we were unable to trap any of the intermediate dihexylgermylenes. However, some evidence for the presence of germylene (**2**) was obtained, as **55** (or an isomer) was produced which could only come from the trapping of germylene (**2**) intermediate, followed by reaction (possibly hydrogermylation) with another molecule of isoprene. However, only traces of these products were produced.

Attempts to synthesize the product **55** through the hydrogermylation of isoprene with 3-methyl-1-germacyclopent-3-ene (**54**) through catalysis with CPA were unsuccessful. However, **55** could be observed in small amounts from the flow pyrolysis of germacyclopentene **54** in the presence of excess isoprene.

### Hexylgermanes

The primary decomposition step in the series of hexylgermanes is not as clear as in the other precursors. There is no doubt that germylene is produced along its reaction profile, but it is difficult to make any mechanistic conclusions based only on the product distribution and a survey of kinetics in the literature. Especially since secondary reactions after the primary decomposition step may greatly effect the product distribution when more than one alkyl group is present. The thermal behavior of the series of hexylgermanes were examined closely in order to elucidate the primary decomposition processes. The Arrhenius parameters of the series of hexylgermanes were measured in an SFR system by following the production of hydrocarbons (1-hexene, 2-hexene, 3-hexene, and hexane). Solution injection of 0.12-0.2 M solutions of the substrate in p-xylene or toluene was used to introduce the compound into the reactor system. These solvents were used because of a) the need to observe the produced hexenes without interference, b) the need for a solvent with high temperature stability (demonstrated through independant

thermolysis) and c.) the need to inhibit radical chain mechanisms that may arise from secondary radicals produced in the decomposition.

The Arrhenius parameters for hexylgermane (**48**) were measured over the temperature range of 440-500 °C following the formation of C<sub>6</sub> hydrocarbons. Decomposition of 15-79% was observed over this temperature range.

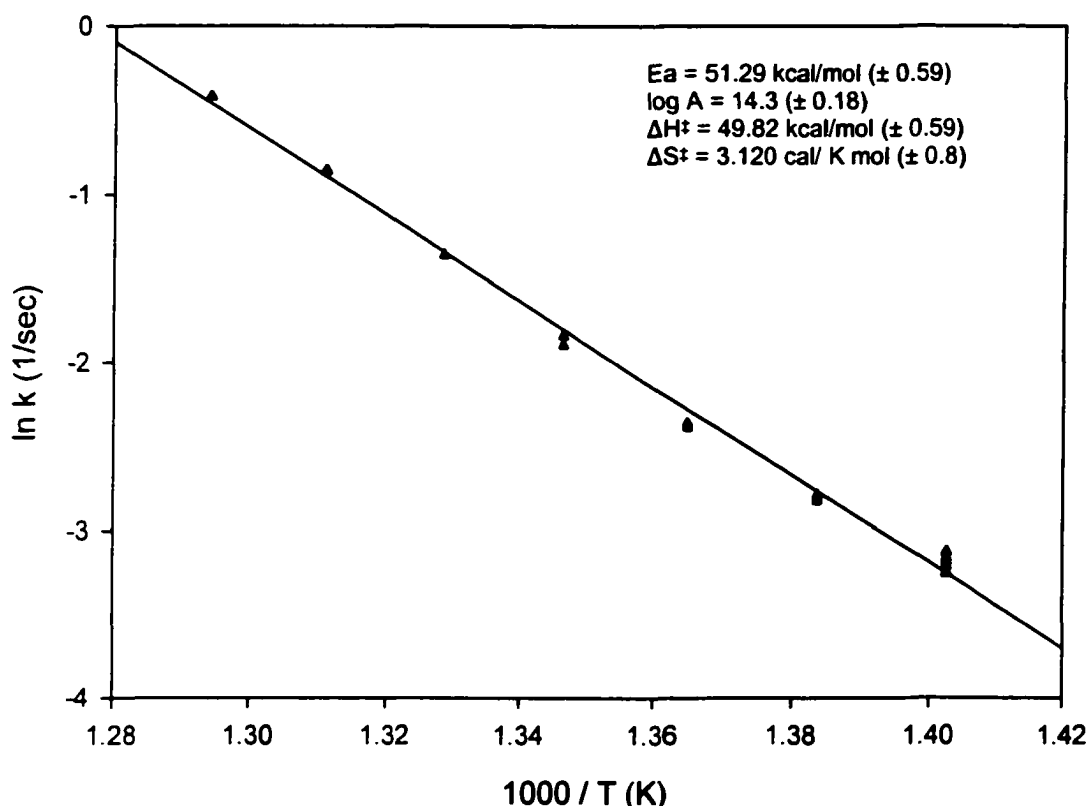

Figure 2. Arrhenius plot of the thermal decomposition of hexylgermane (**48**), over a germanium surface from 440-500 °C following the formation of C<sub>6</sub> hydrocarbons.

Thirty data points were collected (see Figure 2). The  $E_a$  of 51 kcal/mol and  $\log A$  of 14.3 seem quite reasonable for the elimination of H<sub>2</sub> from hexylgermane and compares quite well the values observed for methylgermane, (and for the elimination of H<sub>2</sub> from germane, see Table 13). It seems likely that the hexane observed in the pyrolysis mixture is the result of the molecular elimination of hexane, as observed for methylgermane (**3**).

Table 13. Comparison of Arrhenius parameters to literature results.

substrate	Ea (kcal/mol)	log A	k <sub>500</sub> (/s)	method	Reference
HexGeH <sub>3</sub> <b>48</b>	51.3	14.3	6.3x10 <sup>-1</sup>	SFR	This work
MeGeH <sub>3</sub> <b>3</b>	50.4	13.3	1.2x10 <sup>-1</sup>	shock tube	16
GeH <sub>4</sub> <b>2</b>	52.1	15.5	5.6	shock tube	12
	54.3	15.5	1.4		9

The labeled hexylgermane-d<sub>3</sub> (**48D**) was pyrolyzed in order to further elucidate the mechanism. Deuterium incorporation in the resulting products was determined by mass spectrometry by the method of Biemann<sup>55</sup> with 1-hexene used as a standard. Deuterium incorporation was expected in the product hexenes, due to the process of insertion and 1,2 shifts (Scheme 33). In addition, deuterium incorporation in hexane would be expected if elimination of hexane from the substrate were occurring. The elimination of HD, giving the germene followed by rearrangement would give a hexylgermylene-d<sub>2</sub> (**53D**<sub>2</sub>) through a 1,2-D shift, which could quite possibly lead to incorporation of two deuterium atoms in the resulting hexene. The flow pyrolysis of a solution of hexylgermane-d<sub>3</sub> (**48D**) (0.2 M in toluene) was carried out at 400 C° and the resulting hexenes and their deuterium incorporation analyzed by GC-MS (Scheme 32).

Scheme 32. Deuterium incorporation observed in the products of hexylgermane-d<sub>3</sub> (**48D**) decomposition.

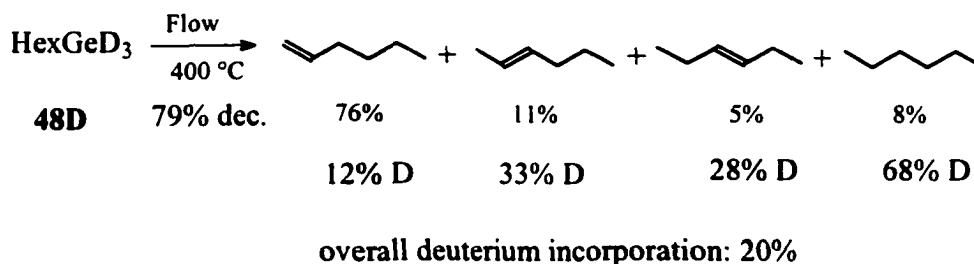



Scheme 33. Proposed mechanisms for deuterium incorporation in the products of hexylgermane-d<sub>3</sub> (**48D**) thermal decomposition.

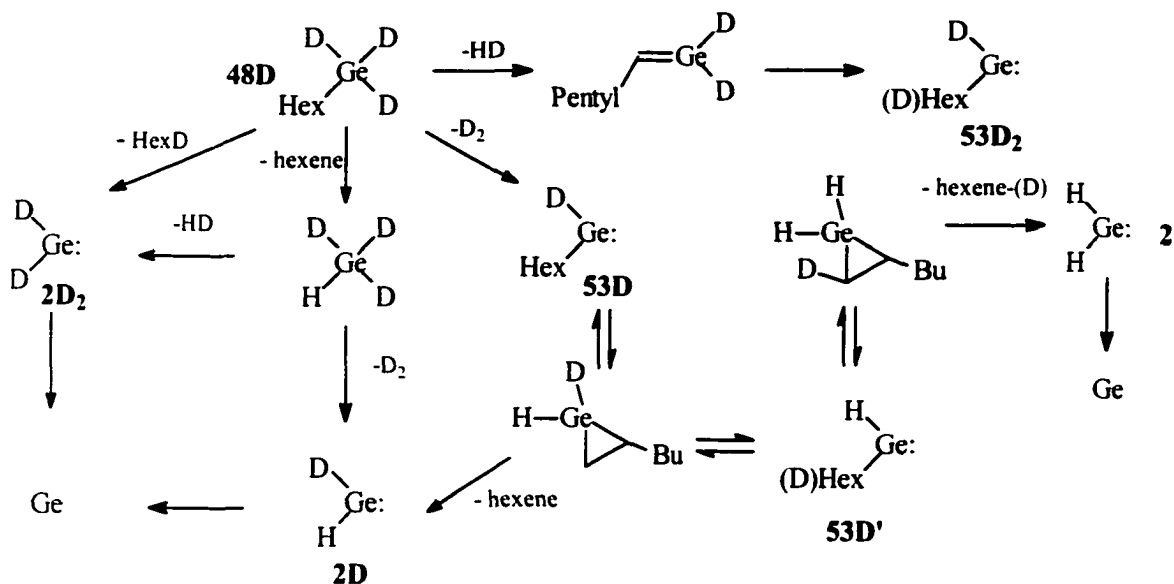

Mostly monodeuteration (22% overall incorporation) was observed, only minor amounts of dideuteration occurred, perhaps ruling out the four-center elimination of HD to form a germene as a primary decomposition mechanism. Hexane had 68% deuterium incorporation, suggesting the presence of concerted geminate elimination of hexane in the decomposition process. The remaining hexenes had from 12%(1-hexene) to around 30% (2- and 3-hexene) deuterium incorporation. The increasing amount of deuterium incorporation can be interpreted as being the result of a greater number of 1,2-H(D) shifts occurring in the germirane intermediates prior to hexene elimination, statistically increasing the chance of incorporation. The fact that the overall deuterium incorporation is low may be because the  $\beta$ -elimination of hexane is occurring, or the elimination from the first formed germirane is fast relative to migration. Elimination from this germirane would give 1-hexene. Based on the data, it is clear that the proposed intramolecular  $\beta$  C-H insertion of the intermediate hexylgermylene **53** is occurring. The primary decomposition pathways include H<sub>2</sub> elimination to form the germirane, and a minor pathway of molecular elimination of hexane.

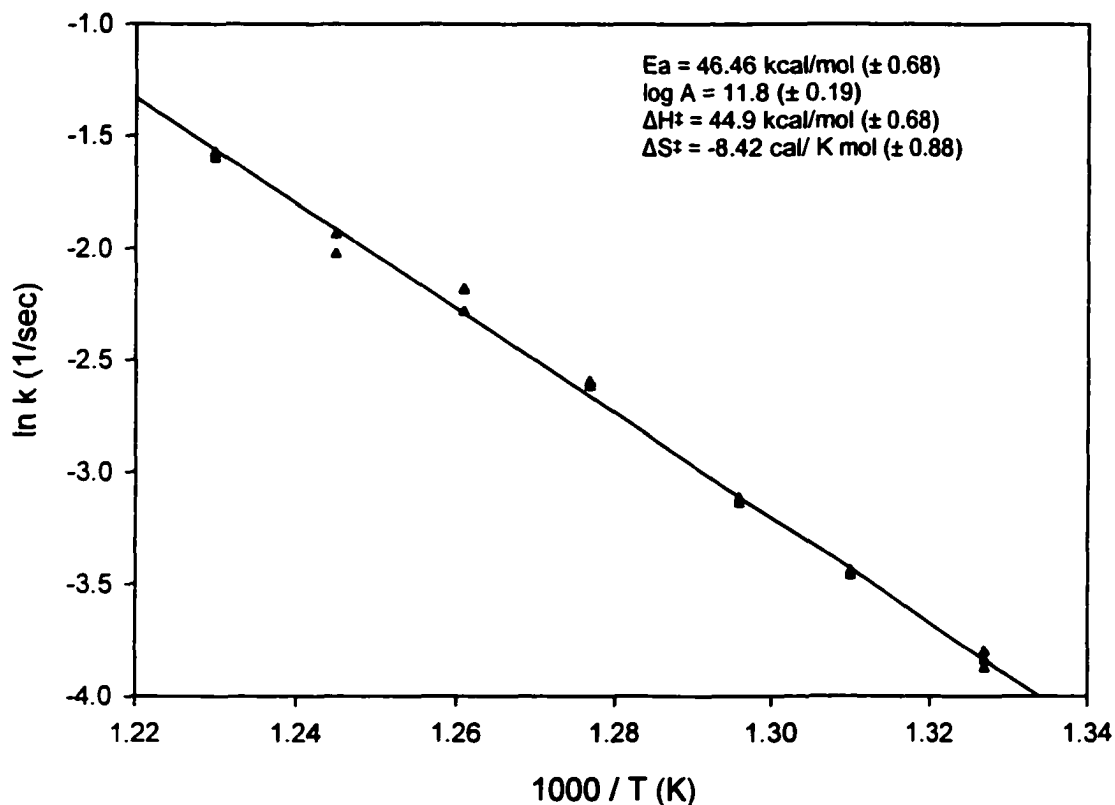
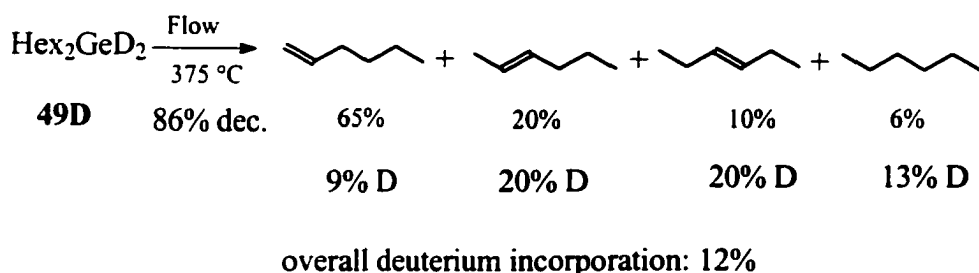

Figure 3. Arrhenius plot of the thermal decomposition of dihexylgermane (**49**), over a germanium surface, from 480-540 °C following the formation of C<sub>6</sub> hydrocarbons.

The Arrhenius parameters for dihexylgermane (**49**) were measured over the temperature range of 480-540 °C following the formation of C<sub>6</sub> hydrocarbons. Decomposition of 28-80% was observed over this temperature range. Twenty eight data points were collected (see Figure 3). The Arrhenius parameters of dihexylgermane (**49**) reveal a slight decrease in activation energy compared to that of hexylgermane (**48**). This was surprising considering the increased temperature required to achieve similar conversion. However, the parameters are consistent with a concerted mechanism, possibly the elimination of hydrogen or the elimination of hexene as opposed to the homolytic cleavage of a Ge-C bond. The hexane

produced in the pyrolysis could mean the participation of the aforementioned molecular elimination of hexane or the beginnings of homolytic cleavage that is still a minor process. The pyrolysis of dihexylgermane-d<sub>2</sub> (**49D**) revealed similar deuterium incorporation (calculated by the same method used in the previous labeling experiment) to the previous hexylgermane-d<sub>3</sub> (**48D**). The proposed mechanisms of deuterium incorporation are shown in Scheme 35.

Scheme 34. Deuterium Incorporation of the products of dihexylgermane-d<sub>2</sub> (**49D**) decomposition.



Deuterium labeling, by <sup>2</sup>H-NMR of isolated 1-hexene



The proposed paths of deuterium incorporation are essentially the same as in hexylgermane-d<sub>3</sub> (**48D**). Deuterium incorporation can occur through only two of the three possible primary processes. The loss of hexane-d gives a hexylgermylene-d (**53D**), which would provide the possibility of deuterium incorporation through the process of insertion and 1,2-hydrogen migration as detailed previously. The other pathway, β-elimination, would give hexylgermane-d<sub>2</sub>, however, no hexylgermane has been observed in the pyrolysis of dihexylgermane. The pathway of D<sub>2</sub> elimination gives a dihexylgermylene which could produce only unlabeled hexenes.

Scheme 35. Proposed mechanisms of deuterium incorporation in the thermal decomposition of dihexylgermane- $d_2$  (**49D**).

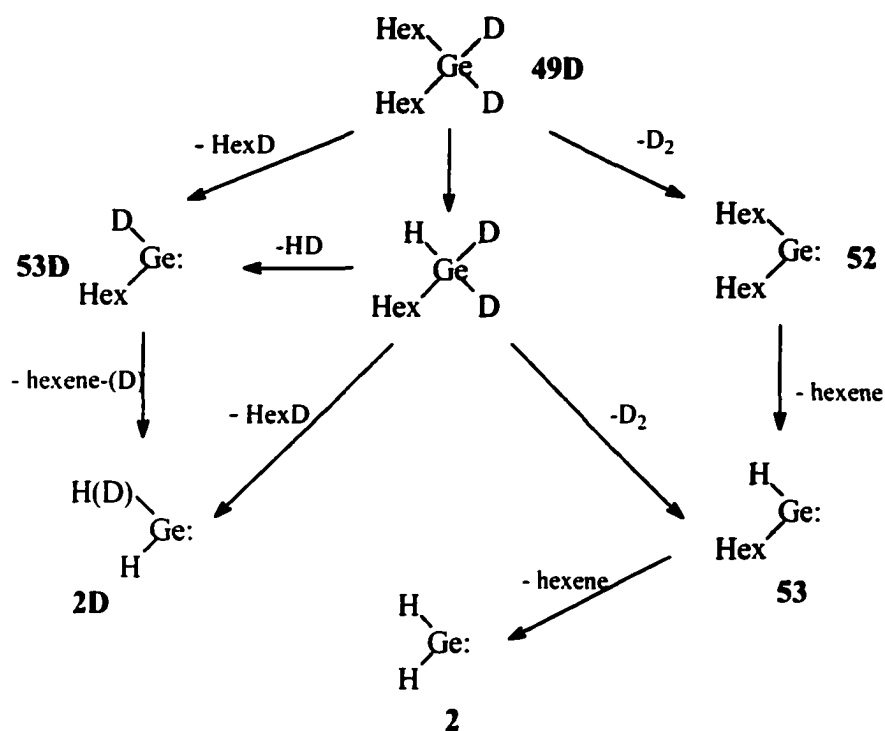

The results of the pyrolysis of dihexylgermane- $d_2$  (**49D**), determined by GC-MS analysis of the pyrolysis products, is shown in Scheme 34. The location of deuterium labeling in 1-hexene, which was isolated by laborious preparative GC-separation, is also shown. For comparison the theoretical deuterium labeling of 1-hexene is shown given random scrambling of deuterium across each position. Not unexpectedly, the overall deuterium incorporation was only 12% (only monodeuteration observed), with the same pattern of greater deuterium incorporation in 2- and 3-hexene. Surprisingly, the hexane was only 13% labeled, suggesting hexane is also produced in secondary processes after the primary decomposition step, or possibly through a minor homolytic cleavage pathway producing a hexyl radical, which then abstracts a proton. The  $^2\text{H}$ -NMR spectrum of 1-hexene revealed that deuterium was concentrated on the 2-position.

The relative importance of the mechanisms of  $\text{H}_2$  loss and  $\beta$ -elimination of hexene is difficult to ascertain based on the available data.  $\beta$ -Elimination is not

precluded because of the absence of hexylgermane, it may be that the small amounts of hexylgermane produced simply decompose, since the temperature involved is above that required to induce decomposition. In order to investigate this a co-pyrolysis experiment was performed. A solution of dihexylgermane- $d_2$  (**49D**) and hexylgermane- $d_3$  (**48D**) (0.13 M and 0.16 M respectively) with p-xylene as an internal standard was prepared and pyrolyzed over the temperature range of 425-520 °C.

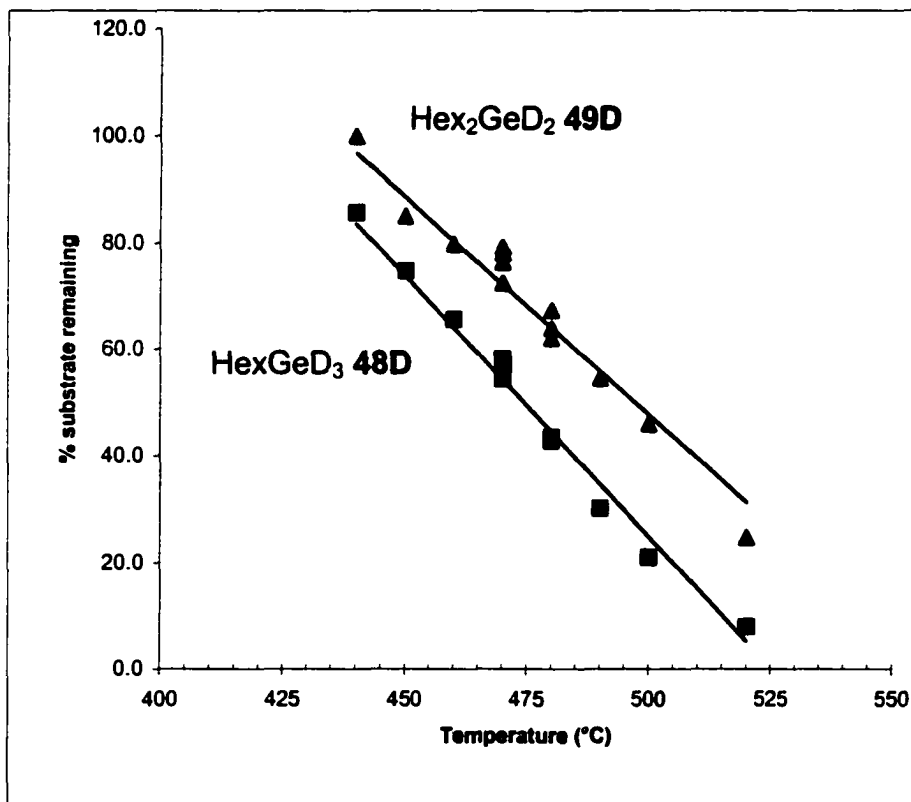

Figure 4. Co-pyrolysis of **48D** and **49D** over a germanium surface.

The results show that the thermal stability of the two compounds are similar, with **48D** showing 13-25% more decomposition at a given temperature than **49D** (Figure 4). The presence of hexylgermane should be evident under the conditions utilized in the pyrolysis of dihexylgermane, and so the operation of the  $\beta$ -elimination mechanism seems unlikely, but cannot be ruled out.

Since there are no kinetic studies in the literature for the decomposition of a dialkylgermane, we can only compare the results to what has been reported for methylgermane, shown in Table 5. Although the Arrhenius parameters are somewhat different, based on the data the compounds primary modes of decomposition are similar.

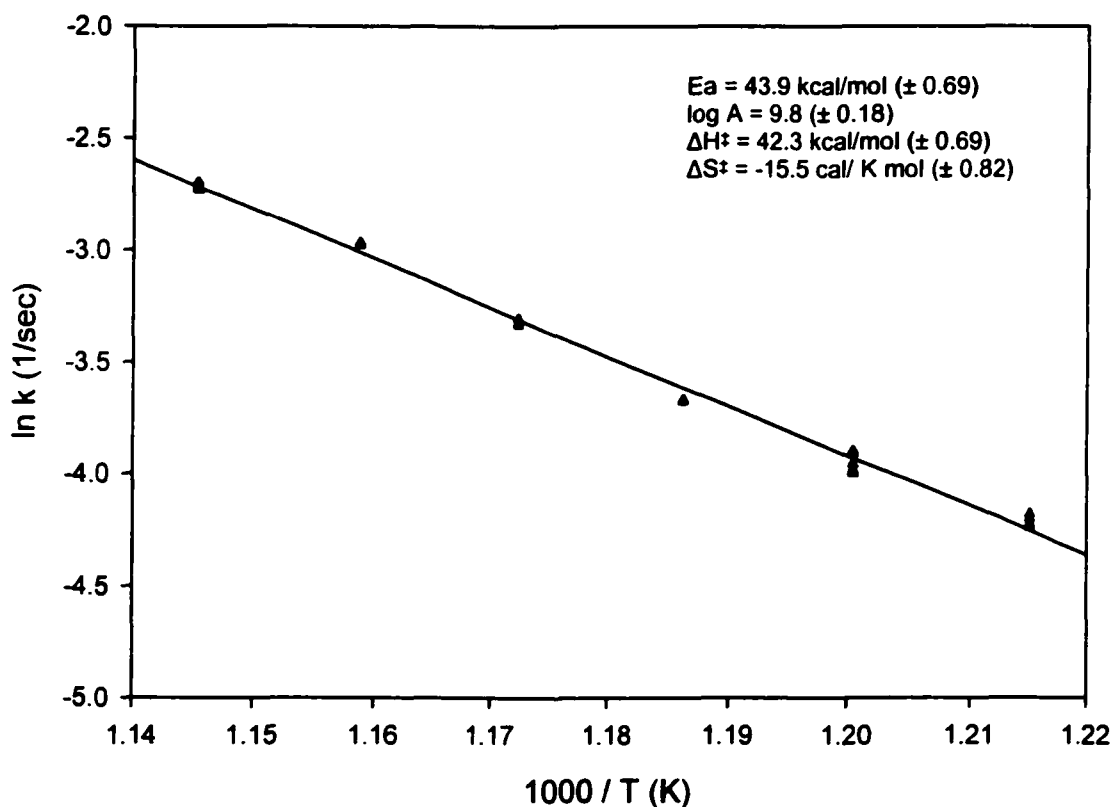

Figure 5. Arrhenius plot of the thermal decomposition of trihexylgermane (**51**), over a germanium surface from 550-600 °C, following the formation of C<sub>6</sub> hydrocarbons.

The Arrhenius parameters of trihexylgermane (**51**) were measured over the temperature range of 550-600 °C following the formation of C<sub>6</sub> hydrocarbons, decomposition of 30-70% was observed over this temperature range. Twenty-three data points were collected (see Figure 5). Both the  $E_a$  and  $\log A$  are again reduced for the decomposition of trihexylgermane (**51**), suggesting the increasing importance

of a competing mechanism that is correlated with the number of alkyl groups present. No direct evidence for major homolytic processes is evident, however it also can not be ruled out. Scheme 36 shows the possible mechanisms for deuterium incorporation into the hydrocarbon products of the decomposition of trihexylgermane-d (**51D**). Three possible initial decomposition pathways are shown. The elimination of hexane-D would give dihexylgermylene (**52**), which could then lose the remaining two hexyl residues by the process of intramolecular  $\beta$  C-H insertion followed by elimination. This pathway would yield labeled hexane, but no labeled hexenes. The middle pathway shown in Scheme 28 begins by  $\beta$ -elimination of unlabeled hexene, giving dihexylgermane-d, which could then decompose by the previously discussed methods. However, hexylgermane intermediates were never observed in the thermolytic experiments. The less stable dihexylgermane and hexylgermane may decompose almost immediately under the higher temperatures involved in these experiments.

If the  $\beta$ -elimination pathway were operative, one would expect to produce labeled hexenes, and a small amount of labeled hexane due to the decomposition of the dihexylgermane-d and hexylgermane-d. The last pathway is that of homolytic cleavage of a Ge-C bond. This would eventually produce a germylene that could produce labeled hexenes. The fate of the hexyl radicals produced in this pathway is most likely hexene, and possibly a small amount of hexane through hydrogen abstraction.

Scheme 36. Deuterium Incorporation pathways in the decomposition of trihexylgermane-d (**51D**).

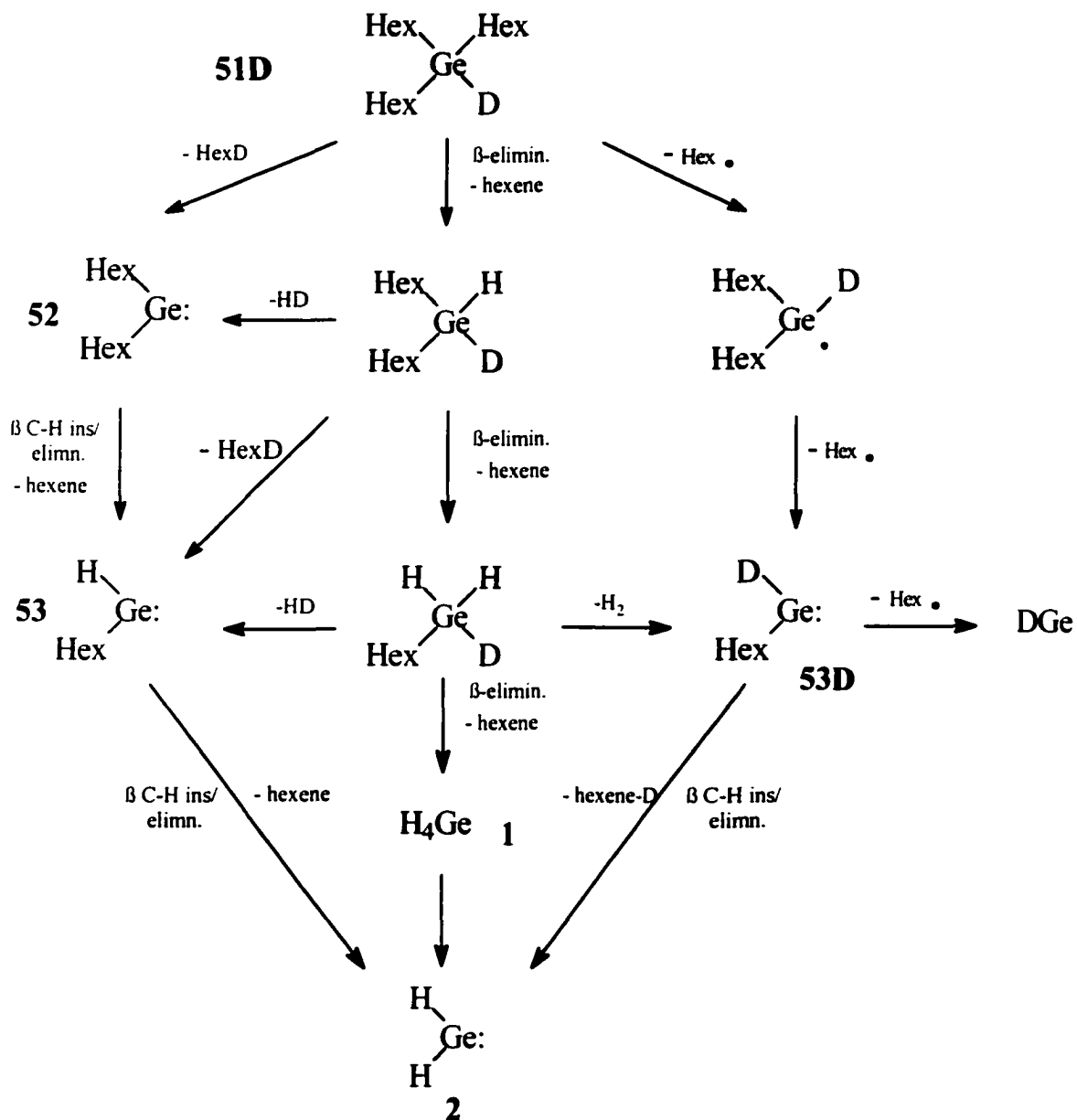



The flow pyrolysis of trihexylgermane-d (**51D**) was carried out (Scheme 37), and deuterium incorporation in the resulting products determined by means of the previously described method. No other germanes were detected in the pyrolysate, however, because of the high temperatures involved, the  $\beta$ -elimination pathway cannot be ruled out. Surprisingly, 9% of the resulting C<sub>6</sub> hydrocarbons produced were labeled, with 14% of the small amount of hexane observed being labeled.

Scheme 37. Deuterium Incorporation of the products of trihexylgermane-d (**51D**) decomposition.

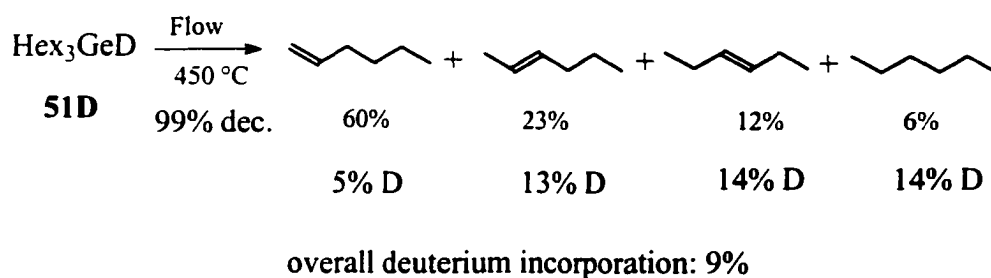

The labeling in hexane demonstrates the presence of geminate elimination of hexane, albeit as a minor pathway. The only source of unlabeled hexane is the homolytic cleavage pathway, which is also the only pathway that could give labeled hexenes, apart from the  $\beta$ -elimination pathway. Although the amount of labeling is small, this may not reflect on the actual amount of the pathway occurring, since not all hexenes produced from this mechanism are labeled.

The previously proposed mechanism of triethylgermane (**14**) decomposition is through consecutive homolytic cleavage (Scheme 12)<sup>32</sup>, with radicals produced in secondary reactions playing a major role in the decomposition process. However, this work was carried out in a static reaction system, conditions which differ significantly from those in a wall-less flow system such as the SFR. Therefore, care must be taken when trying to compare the results. The results obtained for the thermolysis of trihexylgermane (**51**) in the SFR system don't appear to include a major radical component. Instead, the Arrhenius parameters point toward a

concerted mechanism, most likely the molecular elimination of hexane and the  $\beta$ -elimination of hexene as the main routes of primary decomposition.

The next compound in the series, tetrahexylgermane (42) proved to be a difficult compound to study in our SFR system, due to its low volatility and very long retention times in the GC, so tetrabutylgermane was used instead. No difference in kinetic or mechanistic behavior can be expected between the two compounds. The Arrhenius parameters of tetrabutylgermane (19) were measured over the temperature range of 580-640 °C following the formation of C<sub>6</sub> hydrocarbons, decomposition of 8-30% was observed over this temperature range. Twenty-six data points were collected (see Figure 6).

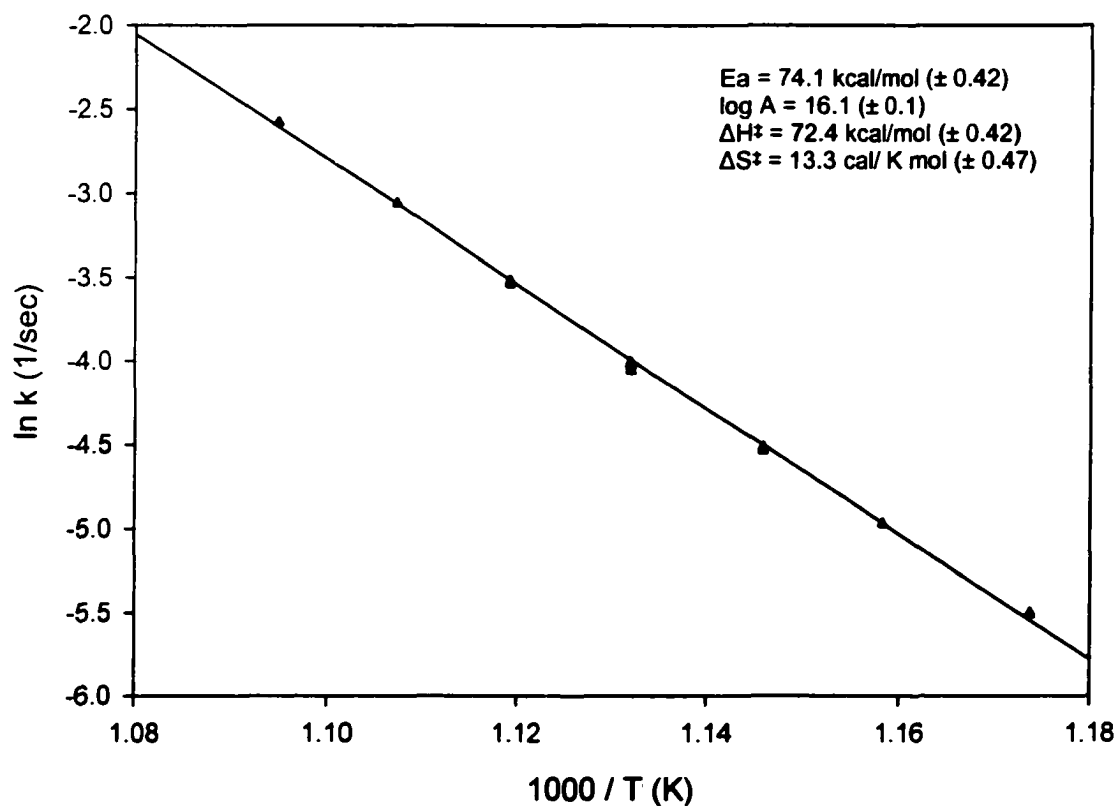
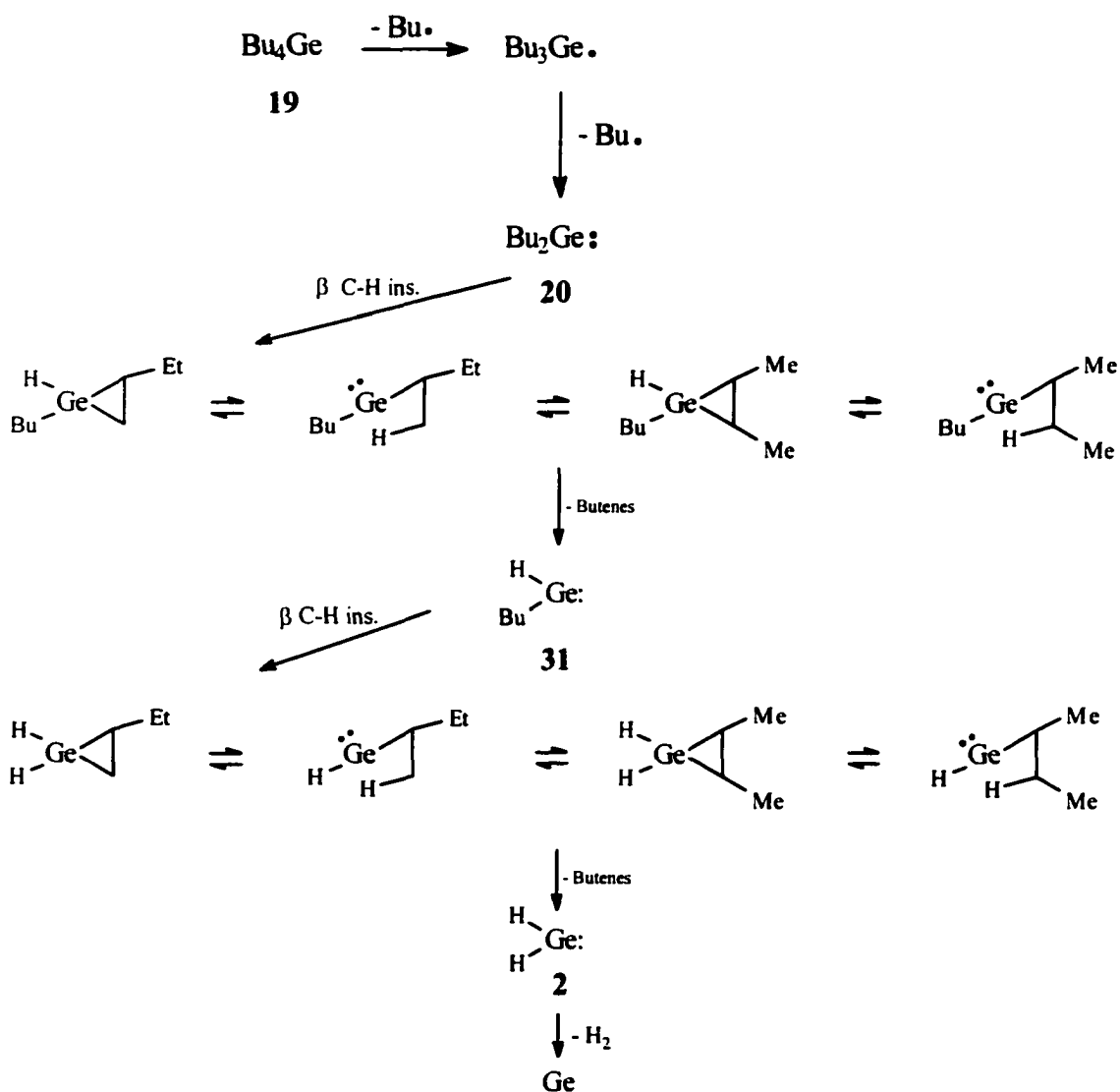

Figure 6. Arrhenius plot of the thermal decomposition of tetrabutylgermane (19), over a germanium surface from 580-640 °C following the formation of C<sub>6</sub> hydrocarbons.

The  $E_a = 74$  kcal/mol and  $\log A = 16$  clearly show the mechanism here to be a homolytic one. 74 Kcal is basically the strength of a Ge-C bond. It is surprising that the product distribution of the pyrolysis of tetrahexylgermane (**42**) (Table 12) is so similar to that of the previous compounds of the series considering the mechanisms are quite different, although it is likely that that main product of hexyl radicals would be hexene.

Scheme 38. Proposed mechanism for the thermal decomposition of tetrabutylgermane (**19**).



It is possible that secondary reactions after the primary Ge-C bond cleavage are overshadowing the products of the primary decomposition step. A mechanism based on the data is proposed in Scheme 38. The proposed mechanism proceeds through the consecutive loss of two butyl groups through homolytic cleavage. The dibutylgermylene then decomposes through the insertion and elimination mechanism proposed earlier.

The Arrhenius parameters reported in the literature for some tetraalkylgermanes are shown in Table 14.

Table 14. Arrhenius parameters of some tetraalkylgermanes.

	Ea kcal/mol	log A	K <sub>500</sub>	method	Ref.
Bu <sub>4</sub> Ge <b>19</b>	74.1	16.6	4.4x10 <sup>-5</sup>	SFR	This work
Et <sub>4</sub> Ge <b>17</b>	51.0	14.3	7.3x10 <sup>-1</sup>	static	36
Me <sub>4</sub> Ge <b>11</b>	68.9	15.4	8.0x10 <sup>-5</sup>	static	25
<710K	51.0	12.1	4.8x10 <sup>-3</sup>	Wall-less	24
>710K	69.0	15.1	3.9x10 <sup>-5</sup>		

An analysis of the available literature leads one to the conclusion that the conditions under which the kinetics of tetraalkylgermanes are measured are quite important. The closest system for comparison to tetrabutylgermane (**19**) is tetraethylgermane (**17**), which displays markedly different Arrhenius parameters, although it is carried out under static conditions. It is possible that secondary chain radical reactions in the static system led to erroneous measurements, but it is difficult then to explain the low temperature Arrhenius parameters of the decomposition of tetramethylgermane (**11**) (measured in a wall-less system) which

are similar. The way conditions effect the rates of decomposition clearly are not well understood.

### Surface effects

The surface effects in the pyrolysis of the hexylgermane series of precursors were first observed when it became apparent that the isomeric distribution of the product hexenes varied when a new column with a fresh silica surface was used. The effects were only observed when the precursor had Ge-H bonds, other precursors such as 3,4-dihexyl-1-germacyclopent-3-ene **40**, and tetrahexylgermane (**41**) showed no surface effects whatsoever. The major isomer produced in the pyrolysis changed from 1-hexene to 2-hexene for similar amounts of conversion at the same flow rate.

Table 15. Products of the flow pyrolysis of dihexylgermylene precursors over a silica surface.

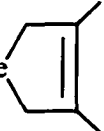
Substrate	T (°C)	Conv (%)	Products (% yield)				
			1-hexene	2-hexene	3-hexene	C <sub>6</sub> H <sub>14</sub>	Other
Hex <sub>2</sub> Ge  <b>40</b>	425	97	33	52	14	-	dmbd
Hex <sub>2</sub> GeD <sub>2</sub> <b>49D</b>	425	70.3	28	47	22	3.5	-
Hex <sub>3</sub> GeD <b>51D</b>	475	82.6	26.5	48.3	22	3	-
Hex <sub>4</sub> Ge <b>42</b>	575	50.6	23	46	14	16	-

Experiments were then carried out where the reactor surface was carefully controlled. The reactor was baked at 700 °C in air 12 hours after each run when a silica surface was needed. To create a Ge/C surface, the reactor was coated by means of the pyrolysis of tetrapropylgermane, after which the reactor was heated at 700 °C for 8 hours under helium. Table 15 shows the results for hexylgermanes **40**, **49D**, **51D**, and **42**. Further key data is shown in Table 16 where the deuterium incorporation of hexenes produced from the same precursor over different reactor surfaces are shown.

Table 16. Deuterium incorporation in the C<sub>6</sub> hydrocarbons produced from the flow pyrolysis of dihexylgermylene precursors over a silica and germanium surfaces.

Substrate	Temp °C	Surface	Conv.	Deuterium incorporation <sup>a</sup>				
				1-h	2-h	3-h	n-h	overall
Hex <sub>2</sub> GeD <sub>2</sub> <b>49D</b>	375	Ge/C	86.1	9	20	20	13	12
Hex <sub>2</sub> GeD <sub>2</sub> <b>49D</b>	425	Silica	70.3	20	26	26	28	24
Hex <sub>3</sub> GeD <b>51D</b>	450	Ge/C	98.6	5	13	14	14	9
Hex <sub>3</sub> GeD <b>51D</b>	475	Silica	82.6	9	17	15	10	14

a. 1-h :1-hexene, 2-h: 2-hexene, 3-h: 3-hexene, n-h: n-hexane

The data clearly shows that the overall deuterium incorporation over a silica surface is higher than that over a Ge/C surface. The most dramatic increase in deuterium incorporation is observed for 1-hexene, while the other isomers only increase slightly. It can be concluded that a surface reaction that produces 1-hexene and does not involve deuterium incorporation is operative when the pyrolysis is carried out over a Ge/C surface. There is evidence in the literature for such a reaction in the case of  $\text{Et}_2\text{GeH}_2$  (**13**) (Scheme 39).<sup>56</sup> The authors report depositing a monolayer through the low temperature (220 °C) surface reaction of  $\text{Et}_2\text{GeH}_2$  (**13**) with a germanium substrate in a high vacuum CVD reactor. After gas evacuation of the precursor and subsequent heating of the substrate to 510 °C, ethylene was produced from the monolayer, with a concomitant growth in germanium film thickness on the substrate. Similar behavior was observed in the static pyrolysis of triethylgermane.<sup>32</sup> The pyrolysis of triethylgermane (**14**) at 355-380 °C for the measurement of the kinetics resulted in the deposition of a silvery metallic film on the reactor surface. After all gaseous products were removed, the reactor was heated to 500 °C.

Scheme 39. Proposed model for atomic layer epitaxy of Ge from  $\text{Et}_2\text{GeH}_2$ .<sup>56</sup>

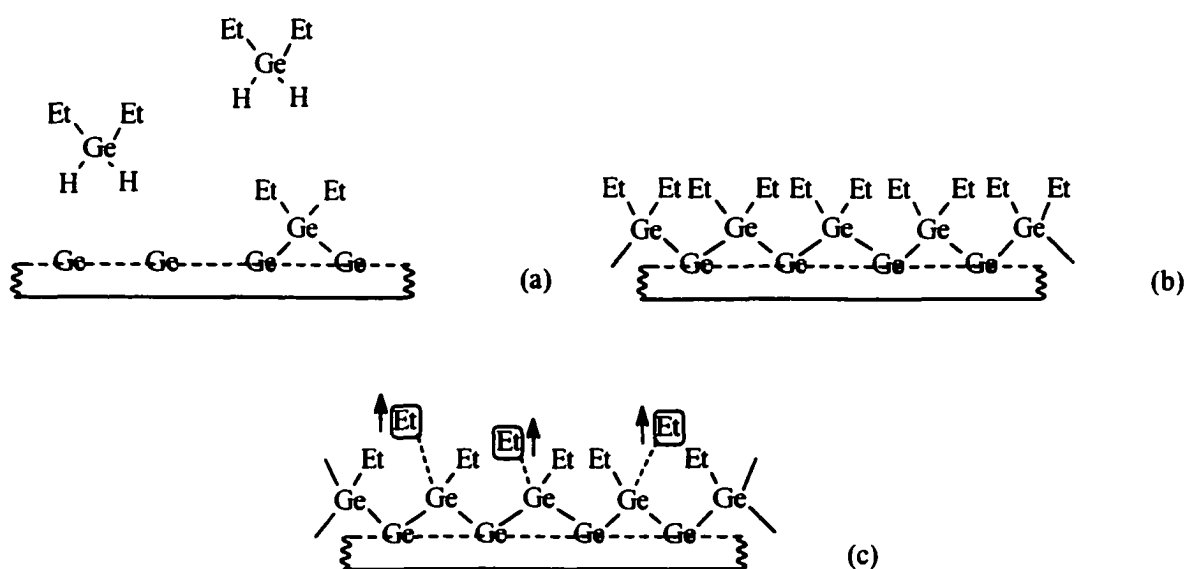

This caused the production of ethene, presumably from the elimination of surface ethyl groups in the deposited film.

It is difficult to estimate the percentage of the reaction pathway that proceeds through this surface reaction. However, a very crude estimate can be obtained if one assumes that 2-hexene, 3-hexene, and *n*-hexane come from homogenous reactions only, the surface reaction produces only 1-hexene, and the ratio of isomers produced in the homogenous reactions pathway is constant. The amount of 1-hexene produced from the gas phase homogenous reaction pathway can be determined and subtracted from the amount of 1-hexene observed, the result of which is the percentage of the reaction proceeding through surface reactions.

For dihexylgermane-d<sub>2</sub> (**49D**), this treatment shows that 17.9% (11.7% of all C<sub>6</sub> hydrocarbons) of the 1-hexene was produced from homogenous reactions. Therefore, the combined amount of C<sub>6</sub> hydrocarbons produced from the homogenous pathway is around 46.5% (11.7% 1-hexene, 19.7% 2-hexene, 9.5% 3-hexene, 5.6% *n*-hexane), while the remainder, 53.5% 1-hexene, is produced from the surface reaction pathway. An examination of the deuterium incorporation shows that overall incorporation is reduced by half, and the incorporation in 1-hexene is reduced by around 55%.

Similar estimates for trihexylgermane-d (**51D**) indicate that 1-hexene produced from the homogenous pathway accounts for 21.5% of 1-hexene (12.8% of total C<sub>6</sub> hydrocarbons). The total percentage of C<sub>6</sub> hydrocarbons produced from the pathway is 54%. The remaining 46% 1-hexene is produced through the surface reaction.

#### A low temperature dihexylgermylene precursor

Unfortunately we had been unable to demonstrate the presence of the intermediate germylenes in the thermolysis studied so far, except for the product which we propose comes from the trapping of germylene (**2**) and subsequent gas phase hydrogermylation. This is not surprising considering the trapping must



compete with an intramolecular process. In an attempt to make a precursor which would generate trappable germynes, methyl(ethyl)trimethylsilyl-germane (**64**) was synthesized.

In this precursor, the low temperature thermal generation of gerylene through geminate elimination of trimethylsilane is utilized, as seen earlier. Only one alkyl residue is susceptible to either  $\beta$ -elimination or  $\beta$  C-H insertion followed by elimination, thus methylgermylene (**4**) would be produced in the reaction. It was hoped that the increased stability imparted by the methyl group would allow the observation of the trapping product of this gerylene.

Scheme 40. Design of of the low-temperature thermal gerylene Precursor, ethylmethyl(trimethylsilyl)germane (**64**).

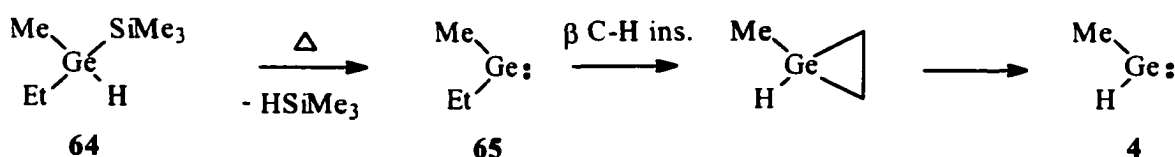

The synthesis of precursor **64** was lengthy, and inelegant since the reactivity of germyl halides does not normally allow selective alkylation. This necessitated the use of phenyls as protecting groups in the synthesis. Methyltriphenylgermane (**58**) was used as the starting material. This was made through the halogenation of tetraphenylgermane (**56**) (synthesized by the reaction of tetrachloro-germane and phenylmagnesium bromide) followed by methylation. Methyltriphenylgermane (**58**) was brominated by reaction with bromine in ethyl bromide, providing the desired germyl bromide **59** in quantitative yield. Ethylation with ethylmagnesium bromide followed, gave ethylmethyl-diphenylgermane (**60**) in quantitative yield. This product was brominated again, then lithium coupling with excess trimethylsilyl chloride was performed to give ethylmethylphenyl(trimethylsilyl)germane (**62**). This step was accompanied by some considerable homocoupling, producing 1,2-diethyl-1,2-dimethyl-1,2-diphenyldigermane, that could not be entirely eliminated. Bromination

of the product at  $-78\text{ }^{\circ}\text{C}$  then was carried out. The low temperature was necessary to limit the brominative cleavage of the germanium-silicon bond that still occurred in small amounts. The resulting bromide **63** was then reduced with lithium aluminum hydride, yielding the desired precursor **64** in 21% overall yield.

Scheme 41. Synthesis of the low temperature thermal germylene precursor, ethylmethyl(trimethylsilyl)germane (**64**).

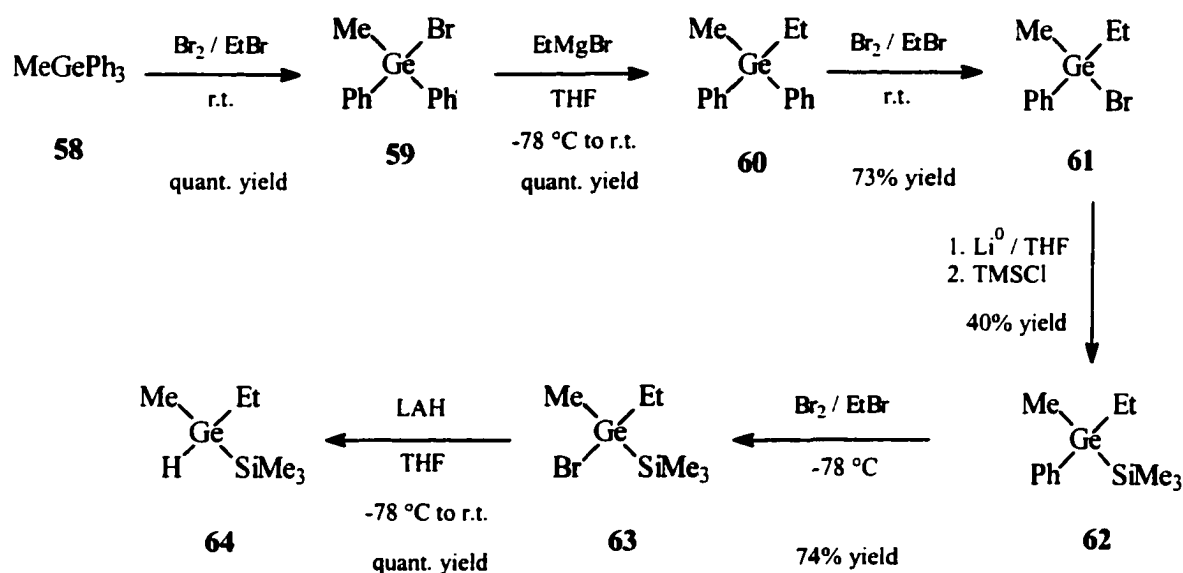

The flow pyrolysis of the precursor **64** was carried out in excess 2,3-dimethyl-1,3-butadiene at  $325\text{ }^{\circ}\text{C}$  with 88% conversion achieved (Scheme 42). The products were tentatively identified first by GC-MS (yields determined by internal standard method) as being 1-ethyl-1,3,4-trimethyl-1-germacyclopent-3-ene (**66**) (12.7% GC yield), 1,3,4-trimethyl-1-germacyclopent-3-ene (**67**) (15.3%), and 1-(dimethyl-2-butenyl)-1,3,4-trimethyl-1-germacyclopent-3-ene (**68**) (60%). The major product apparently being the hydrogermylation product of 1,3,4-trimethylgermacyclopent-3-ene and 2,3-dimethyl-1,3-butadiene. The products were isolated by preparative gas chromatography, with the loss of a considerable amount of material, however, isolated yields were obtained of 4.8%, 4% and 16% respectively.

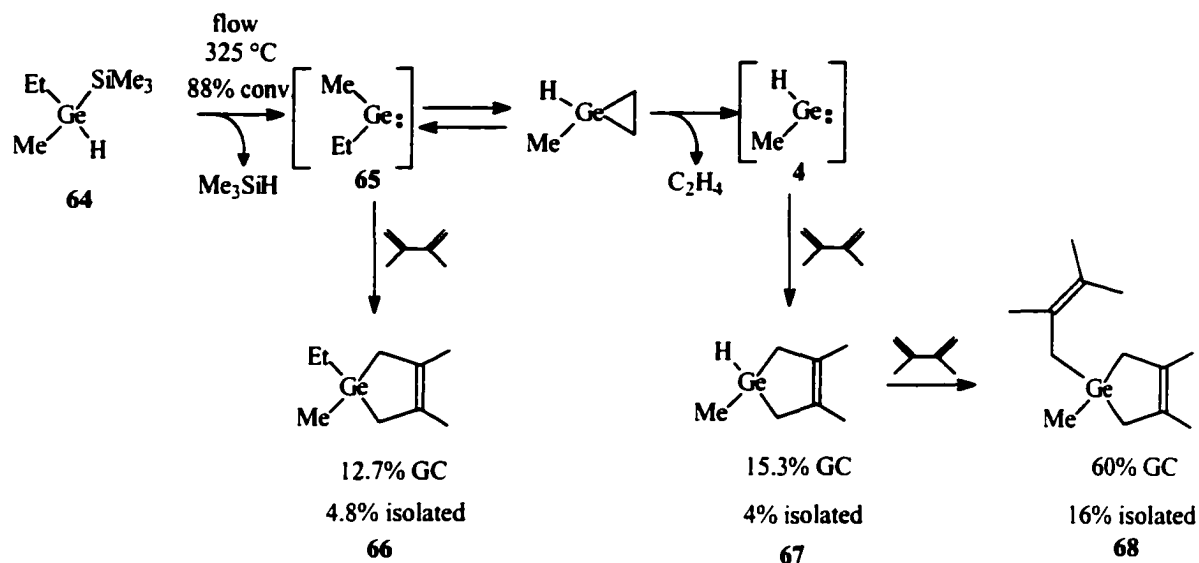
Scheme 42. Flow pyrolysis of ethylmethyl(trimethylsilyl)germane (**64**).

Full characterization of the materials with the amounts obtained after preparative GC was not possible, however,  $^1\text{H}$  NMR was obtained, and for the last product  $^{13}\text{C}$  NMR was obtained as well. Characterization of the above molecules was obtained by separate syntheses (shown in Scheme 43). A brute force method was employed to synthesize the first two molecules, which employed the common intermediate 1-methyl-1-chloro-1-germacyclopent-3-ene (**70**). 1,1-Diiodo-3,4-dimethylgermacyclopent-3-ene was transformed into the 1,1-dichloro-3,4-dimethylgermacyclopent-3-ene (**69**) by reaction in aqueous 10% NaOH, forming a solid polygermoxide. This material provided the dichlorogermacyclopentene **69** upon treatment with concentrated HCl and subsequent extraction. Dichlorogermacyclopentene **69** was utilized because the diiodo compound was only partly soluble in the solvents employed, the result being that only dimethylgermacyclopentene **38** was produced from the methyl Grignard reaction with diiodogermacyclopentene. The chloroide **69** was reacted with 1 equivalent of methyl Grignard reagent at  $-78^\circ\text{C}$ . Partial methylation was achieved and the reaction mixture was worked up and distilled, giving  $\approx 70\%$  yield of the mixture of three compounds; **38**, the partially methylated **70**, and unreacted starting material **69**. Reduction of this mixture with LAH gave the desired compound **67**, which was

isolated by distillation followed by preparative GC. Treatment of the mixture with ethyl magnesium bromide gave the desired mixed alkyl product **66**, which again was isolated by distillation followed by preparative GC. Both compounds mass spectra and  $^1\text{H}$  NMR spectra matched exactly the spectra of the compounds observed in the thermolysis of ethylmethyl(trimethylsilyl)germane **64**.

Scheme 43. Separate synthesis of Pyrolysis products.

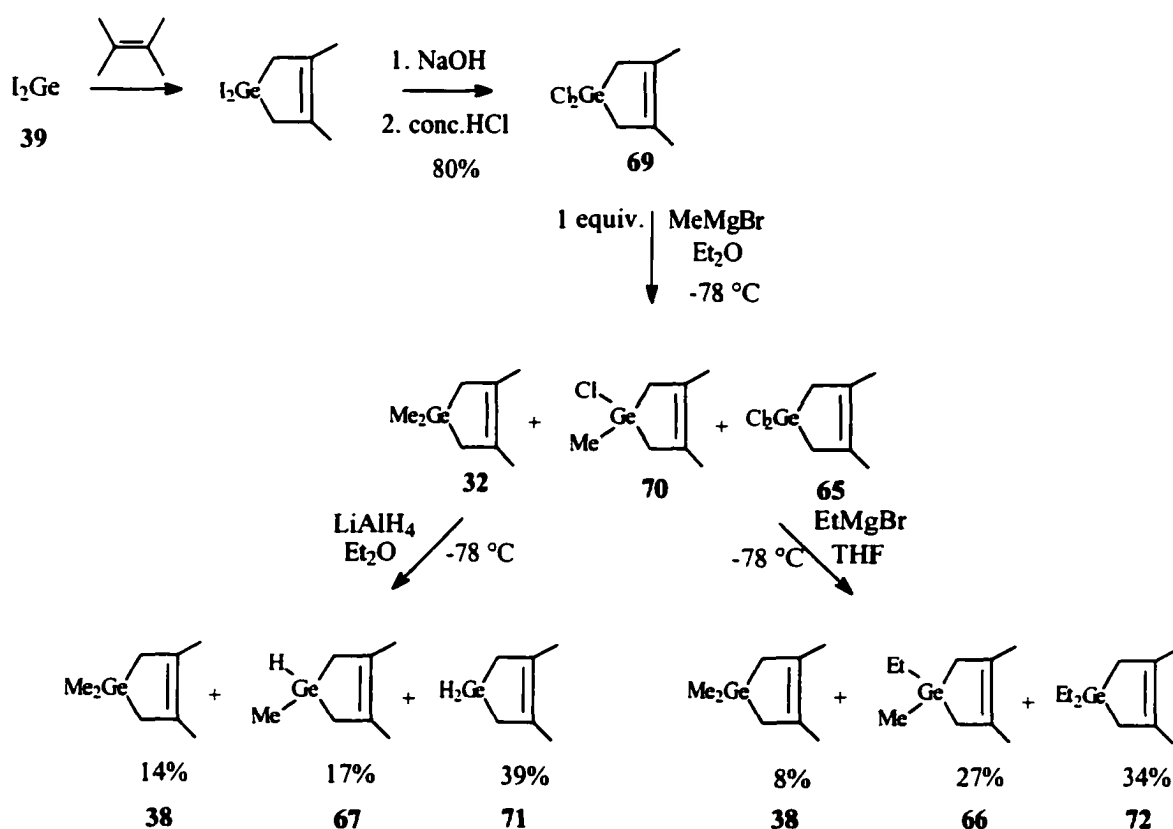

The last compound **68** has not been fully characterized yet, but it has been reproduced by thermolysis of 1,3,4-trimethyl-1-germacyclopent-3-ene in the presence of excess 2,3-dimethyl-1,3-butadiene.

The products produced in the thermolysis clearly demonstrate the presence of both germlyenes in the decomposition.

## Conclusion

The thermal decomposition of a series of dihexylgermylene precursors has been investigated and their Arrhenius parameters compared to literature values where possible. A mechanism of intramolecular  $\beta$  C-H insertion to form an intermediate germirane, followed by either elimination of hexene or a 1,2-hydrogen shift to reform germylene was proposed. This process allowed the migration of germanium up and down the alkyl chain. The presence of the 1,2-hydrogen shift was demonstrated by the observation of deuterium incorporation in the hexenes produced from the deuterium labeled precursors (hexylgermane- $d_3$  (**48D**), dihexylgermane- $d_2$  (**49D**), and trihexylgermane- $d$  (**51D**)). The mechanisms of the decomposition of these precursors are complex, and most likely include more than one pathway operating simultaneously. Surface effects were observed in the decompositions (over a Ge/C coated reactor) of precursors containing a Ge-H bond. Under those conditions, the distribution of hexene isomers produced was shifted in favor of 1-hexene. It is proposed that a surface reaction which formed a layer of hexylated germanium could occur, and that consecutive elimination of 1-hexene from this layer would explain the relative increase in 1-hexene observed. The proposed mechanism for the decomposition of dialkylgermylene was further supported by demonstrating the presence of key intermediates. The intermediacy of dialkylgermylene and alkylgermylene was shown through trapping experiments with 2,3-dimethyl-1,3-butadiene in the thermolysis of the low temperature germylene precursor ethylmethyl(trimethylsilyl)germane (**64**).

## Experimental Section

Preparative gas chromatography was carried out on a Varian 920 gas chromatograph equipped with thermal conductivity detector and a chart recorder using the column indicated. Helium was used as the carrier gas.

A pulsed- stirred flow reactor (SFR) was used for the kinetic measurements, which is similar to the previously described design of Baldwin et. al.<sup>57</sup> The SFR reactor consisted of a quartz reactor with a volume of 4 cm<sup>3</sup>. The reactor was heated by an oven controlled by a Digi-Sense temperature controller. The reactor was connected to a Varian 6000 gas chromatograph (30 m DB-5 Megabore column, FID detector) by heated transfer line. Data was recorded on a Hewlett Packard 3390A integrator and a Magnum XT/Mark 2 microcomputer. Helium was used (60 mL/min flow rate) as the carrier gas.

Flow pyrolysis was carried out using a vertical 50 cm quartz tube (interior diameter of 15 mm) packed with quartz chips. The tube was heated by an oven controlled by a Digi-Sense temperature controller.

<sup>1</sup>H and <sup>13</sup>C NMR spectra were acquired on a Varian VXR-300 spectrometer. Chemical shifts are reported in parts per million with the indicated solvent as standard. Proton splitting is reported using standard abbreviations. Routine infrared spectra are reported in wave numbers (cm<sup>-1</sup>) and were obtained on a Bio-Rad Digilab FTS-7 spectrometer from a neat sample (except where noted). Other IR spectra were obtained on a Hewlett Packard GC-IR-MS (GC: HP 5890, IR: HP 5965A, MSD: HP 5970). UV/Vis spectra were obtained using a Hewlett Packard 8452A diode array UV/Vis spectrometer. Mass spectra are reported as m/z (relative intensity) and were obtained on the previously described GC-MS-IR or a Hewlett Packard GC-MS (GC: HP 5890 series II, MSD: HP 5972). Exact masses were acquired on a Kratos MS 50 mass spectrometer. Quantitative gas chromatography was performed on a Hewlett Packard 5890 series II GC equipped with a flame ionization detector. Except where indicated a 30 m 0.25 mm i.d. capillary column

with DB-5 stationary phase was utilized for all gas chromatography. The carrier gas used was helium.

THF and ether were distilled over sodium-benzophenone right before use. For rigorous drying, THF was subjected to a second distillation over lithium aluminum hydride before use. Other reagents were used as received (without further purification) from Aldrich, Fisher Chemical, or Gelest except where indicated.

**Germanium diiodide (39).** This compound was made according to the literature.<sup>58</sup> A flask was fitted with addition funnel, condenser, and stirbar. The apparatus was flushed with argon and charged with germanium dioxide (30 g, 287 mmol) and 47% hydrogen iodide (20 mL). The mixture was refluxed for 15 min, at which time the reddish germanium tetraiodogermane precipitate was visible. Next a solution of 47% hydrogen iodide (100 mL) and hypophourous acid (63 mL) was added by an addition funnel. The solution was then heated to reflux for 1 h. Gold germanium diiodide precipitate formed. This precipitate was isolated by filtration under argon and rinsed with 5% aq. HI (3 x 75 mL). After drying, **39** was obtained as a gold crystalline material (78 g, 238.8 mmol, 83%).

**1,1-Dibutyl-1-germacyclopent-3-ene (21).** A modification of the procedure of Takeuchi was used in the synthesis of **21**.<sup>48</sup> A 100 mL flask equipped with a J. Young valve was charged with germanium diiodide (3.27 g, 10 mmol) and hexane (10 mL). Next the reaction was flushed with argon and cooled to  $-78$  °C. 1,3-Butadiene (0.6 g, 11.1 mmol) was condensed into the vessel then it was sealed. The reaction mixture was stirred at room temperature for 6 h, then heated to 50 °C for 2 h. The resulting 1,1-diiodo-1-germacyclopent-3-ene was transferred to a flask containing butylmagnesium chloride (20 mL, 40 mmol, 2.0 M in ether) cooled to  $-78$  °C. The reaction mixture was allowed to stir for 15 min, then warm to room temperature and stir for 2 h. The reaction mixture was quenched in HCl (2 M, 100 mL), then extracted with pentane (2 x 75 mL). The combined organic layer was washed with sat. sodium bicarbonate (75 mL), water (75 mL) and sat. sodium chloride (75 mL) then dried over magnesium sulfate. Solvent removal *in vacuo* followed by distillation provided **21** (1.9 g, 7.9 mmol, 79%) as a clear liquid (b.p. 82-

84 °C/2 torr).  $^1\text{H}$  NMR ( $\text{CDCl}_3$ )  $\delta$  5.94 (t,  $J = 0.8$  Hz, 2H,  $\sim\text{CH}_2(\text{H})\text{C}=\text{C}\sim$ ), 1.43 (d,  $J = 0.8$  Hz, 4H,  $\sim\text{CH}_2(\text{H})\text{C}=\text{C}\sim$ ), 1.34-1.31 (m, 8H,  $\sim\text{Ge}(\text{C}_4\text{H}_9)_2$ ), 0.93-0.86 (m, 10H,  $\sim\text{Ge}(\text{C}_4\text{H}_9)_2$ );  $^{13}\text{C}$  NMR ( $\text{CDCl}_3$ )  $\delta$  131.7, 27.7, 26.3, 16.0, 14.0, 13.9; GC-IR-MS ( $\text{cm}^{-1}$ ) 3020, 2965, 2927, 1099. GC-MS (EI):  $m/z$  244 (4), 242 ( $\text{M}^+$ , 18), 241 (6), 240 (13), 238 (10), 190 (13), 189 (6), 188 (64), 187 (21), 186 (49), 185 (18), 184 (40), 183 (10), 181 (7), 160 (4), 134 (16), 133 (11), 132 (86), 313 (47), 130 (100), 129 (50), 128 (76), 127 (32), 126 (24), 125 (14), 113 (4), 105 (4), 104 (5), 103 (21), 102 (11), 101 (29), 100 (18), 99 (24), 98 (4), 97 (11), 91 (9), 89 (37), 88 (11), 87 (27), 85 (20), 76 (7), 75 (11), 74 (31), 73 (15), 72 (22), 71 (6), 70 (16), 57 (4), 55 (8); HRMS (EI)  $m/z$  calcd for  $\text{C}_{12}\text{H}_{24}\text{Ge}$  242.109186, found 242.109587.

**1,1-Dihexyl-3-methyl-1-germacyclopent-3-ene (41).** A modification of the procedure of Takeuchi was used in the synthesis of **41**.<sup>48</sup> A solution of germanium diiodide (3.88 g, 10.3 mmol), isoprene (1.4 mL), and hexane (10 mL) was sealed in a vessel and stirred for 6 h at room temperature, then heated to 50 °C for 2 h. Next the product was transferred to a flask containing *n*-hexylmagnesium bromide (20 mL, 40 mmol, 2.0 M in THF) at  $-78$  °C and stirred for 15 min. The reaction mixture was warmed to room temperature and stirred for 1 h. The reaction mixture was then quenched in HCl (2 M, 100 mL) and extracted with pentane (2 x 75 mL). The combined organic layer was washed with sat. sodium bicarbonate (75 mL), water (75 mL), and sat. sodium chloride (75 mL) then dried over magnesium sulfate. Solvent removal *in vacuo* followed by distillation gave **41** (3.06 g, 9.8 mmol, 95%) as a clear liquid (b.p. 107-109 °C/1.5 torr).  $^1\text{H}$  NMR ( $\text{CDCl}_3$ )  $\delta$  5.67 (sex.,  $J = 1.4$  Hz, 1H,  $\sim\text{CH}_2(\text{CH}_3)\text{C}=\text{C}(\text{H})\text{CH}_2\sim$ ), 3.77 (m, 2H,  $\sim\text{CH}_2(\text{CH}_3)\text{C}=\text{C}(\text{H})\text{CH}_2\sim$ ), 3.63 (t,  $J = 6.6$  Hz, 2H,  $\sim\text{CH}_2(\text{CH}_3)\text{C}=\text{C}(\text{H})\text{CH}_2\sim$ ), 1.8 (m, 3H,  $\sim\text{CH}_2(\text{CH}_3)\text{C}=\text{C}(\text{H})\text{CH}_2\sim$ ), 1.43-1.26 (m, 14H,  $\sim\text{GeC}_6\text{H}_{13}$ ), 0.90-0.85 (m, 12H,  $\sim\text{GeC}_6\text{H}_{13}$ );  $^{13}\text{C}$  NMR ( $\text{CDCl}_3$ )  $\delta$  140.5, 125.6, 32.9, 31.6, 25.4, 22.6, 20.8, 17.2, 14.5, 14.2; IR (neat,  $\text{cm}^{-1}$ ) 2997, 2956, 2923, 2852, 1456, 1147, 1007, 720, 667, 597; GC-MS (EI):  $m/z$  314 (4), 313 (4), 312 ( $\text{M}^+$ , 18), 311 (7), 310 (13), 308 (10), 246 (8), 245 (5), 244 (37), 243 (13), 242 (28), 240 (20), 229 (9), 228 (11), 227 (37), 226 (15), 225 (26), 224 (6), 223 (18), 162 (18), 161 (17), 160 (92), 159 (100), 157 (43), 156 (72), 155 (24), 154 (17), 145 (19), 144



(7), 143 (50), 142 (15), 141 (41), 140 (5), 139 (29), 137 (4), 134 (4), 133 (4), 132 (18), 131 (17), 130 (22), 129 (15), 128 (17), 127 (12), 126 (4), 125 (4), 119 (4), 118 (9), 117 (18), 116 (15), 115 (24), 114 (13), 113 (19), 112 (9), 111 (9), 105 (7), 103 (26), 102 (10), 101 (31), 100 (8), 99 (23), 97 (8), 91 (9), 89 (37), 88 (10), 87 (29), 85 (23), 84 (5), 83 (43), 82 (6), 81 (5), 75 (7), 74 (10), 73 (7), 72 (6), 71 (4), 70 (5), 67 (5), 55 (21), 53 (4); HRMS (EI)  $m/z$  calcd for  $C_{17}H_{34}Ge$  312.187550, found 312.187393.

**Flow pyrolysis of 1,1-dihexyl-3-methyl-1-germacyclopent-3-ene (41) over a germanium surface.** A solution of **41** (1.005 g, 3.221 mmol), heptane (0.110 g) as internal standard, in toluene (19.4 mL) was added dropwise through a 50 cm vertical quartz tube packed with quartz chips at 450 °C with a flow rate of 60 mL/min (He). The column surface had been coated with Ge/C by CVD. The pyrolysate was collected in a flask at -116 °C in an ethanol/N<sub>2</sub> bath. Conversion was 84.7% based on the remaining starting material. The following volatile products were observed (identified based on MS and comparison to known compounds, yields were determined by the internal standard method using appropriate Rfs and are total yields based on 100% conversion): 1-hexene (90.2 mg, 1.0734 mmol, 16.7%), *trans*-2-hexene (144.4 mg, 1.7185 mmol, 26.7%), *trans*-3-hexene (49.0 mg, 0.5829 mmol, 9.0%), and isoprene (80.3 mg, 1.1815 mmol, 37%). Total yield of C<sub>6</sub> hydrocarbons was 52.4%.

**1,1-Dihexyl-3,4-dimethyl-1-germacyclopent-3-ene (40).** A modification of the procedure of Takeuchi was used in the synthesis of **40**.<sup>48</sup> A solution of germanium diiodide (3.27 g, 10 mmol), 2,3-dimethyl-1,3-butadiene (1.1 g, 1.52 mL, 13 mmol), and hexane (10 mL) was sealed in a vessel and stirred for 6 h at room temperature, then heated to 60 °C for 4 h. Next the product was transferred to a flask containing *n*-hexylmagnesium bromide (20 mL, 40 mmol, 2.0 M in THF) at -78 °C and stirred for 15 min. The reaction mixture was warmed to room temperature and stirred for 1 h. The reaction mixture was then quenched in HCl (2 M, 100 mL) and extracted with pentane (2 x 75 mL). The combined organic layer was washed with sat. sodium bicarbonate (75 mL), water (75 mL), and sat. sodium chloride (75

mL) then dried over magnesium sulfate. Solvent removal *in vacuo* followed by distillation gave **40** (2.34 g, 7.2 mmol, 71%) as a clear liquid (b.p. 120-123 °C/1.5 torr). <sup>1</sup>H NMR (CDCl<sub>3</sub>) δ 1.69 (s(br), 6H, ~CH<sub>2</sub>(CH<sub>3</sub>)C=C~), 1.48 (d, *J* = 0.9 Hz, 4H, ~CH<sub>2</sub>(CH<sub>3</sub>)C=C~), 1.40-1.27 (m, 14H, ~Ge(C<sub>6</sub>H<sub>13</sub>)<sub>2</sub>), 0.90-0.82 (m, 12H, ~Ge(C<sub>6</sub>H<sub>13</sub>)<sub>2</sub>); <sup>13</sup>C NMR (CDCl<sub>3</sub>) δ 131.0, 32.9, 31.7, 25.5, 24.0, 22.7, 19.6, 14.2, 14.1; IR (neat, cm<sup>-1</sup>) 2956, 2923, 2854, 1465, 1376, 1170, 842, 738, 696; GC-MS (EI): *m/z* 328 (5), 327 (5), 326(M<sup>+</sup>, 23), 325 (9), 324 (16), 322 (13), 244 (10), 243 (15), 242 (16), 241 (57), 240 (24), 239 (41), 238 (6), 237 (30), 162 (11), 161 (12), 160 (56), 159 (57), 158 (66), 157 (100), 156 (63), 155 (74), 154 (15), 153 (46), 151 (4), 145 (7), 143 (6), 141 (6), 132 (13), 131 (12), 130 (15), 129 (12), 128 (12), 127 (10), 118 (5), 117 (15), 116 (11), 115 (26), 114 (11), 113 (21), 112 (4), 111 (11), 105 (5), 103 (18), 102 (6), 101 (19), 89 (33), 88 (8), 87 (25), 85 (19), 84 (4), 83 (32), 82 (5), 81 (5), 75 (5), 74 (7), 73 (5), 72 (5), 55 (18); HRMS (EI) *m/z* calcd for C<sub>18</sub>H<sub>36</sub>Ge 326.203226, found 326.203595.

**Flow pyrolysis of 1,1-dihexyl-3,4-dimethyl-1-germacyclopent-3-ene (40) over a germanium surface.** A solution of **40** (1.030 g, 3.160 mmol), octane (0.032 g) as an internal standard, and toluene (19.9 mL) was added by syringe over 15 min through a 50 cm vertical quartz tube packed with quartz chips at 450 °C with a flow rate of 60 mL/min (He). The column surface had been coated with Ge/C by CVD. The pyrolysate was collected in a flask cooled to -116 °C in an ethanol/N<sub>2</sub> bath. The pyrolysate was analyzed by GC-MS using internal standard techniques. The conversion was 64.7% based on the remaining starting material, with no other germanium products being observed. The following volatile products were observed (identified based on MS and comparison to known compounds, yields were determined by the internal standard method using appropriate R<sub>f</sub>s and are total yields based on 100% conversion): 1-hexene (51.5 mg, 0.6128 mmol, 9.7%), *trans*-2-hexene (111.7 mg, 1.3297 mmol, 21.0%), *trans*-3-hexene (41.5 mg, 0.4935 mmol, 7.8%), and 2,3-dimethyl-1,3-butadiene (41.4 mg, 0.5049 mmol, 16%). Total yield of C<sub>6</sub> (excluding 2,3-dimethyl-1,3-butadiene) hydrocarbons was 38.6%.

**Flow pyrolysis of 1,1-dihexyl-3,4-dimethyl-1-germacyclopent-3-ene (40) over a silica surface.** A solution of **40** (0.107 g, 0.328 mmol), *p*-xylene (0.055 g) as an internal standard, and toluene (3.0 mL) was added by syringe over 15 min through a 50 cm vertical quartz tube packed with quartz chips at 450 °C with a flow rate of 60 mL/min (He). The pyrolysate was collected in a flask cooled to -116 °C in an ethanol/N<sub>2</sub> bath. The pyrolysate was analyzed by GC-MS using internal standard techniques. The conversion was 97.2% based on the remaining starting material, with no other germanium products being observed. The following volatile products were observed (identified based on MS and comparison to known compounds, yields were determined by the internal standard method using appropriate Rf's and are total yields based on 100% conversion): 1-hexene (17.9 mg, 0.2135 mmol, 32.5%), *trans*-2-hexene (28.1 mg, 0.3344 mmol, 50.9%), *trans*-3-hexene (7.5 mg, 0.0903 mmol, 13.8%), and 2,3-dimethyl-1,3-butadiene (13.9 mg, 0.1692 mmol, 51.5%). Total yield of C<sub>6</sub> (excluding 2,3-dimethyl-1,3-butadiene) hydrocarbons was 97%.

**1,1-Dibutyl-3,4-dimethyl-1-germacyclopent-3-ene (22).** A modification of the procedure of Takeuchi was used in the synthesis of **22**.<sup>48</sup> A solution of germanium diiodide (3.27 g, 10 mmol), 2,3-dimethyl-1,3-butadiene (1.1 g, 1.52 mL, 13 mmol), and hexane (10 mL) was sealed in a vessel and stirred for 6 h at room temperature, then heated to 60 °C for 4 h. Next the product was transferred to a flask containing butylmagnesium chloride (20 mL, 40 mmol, 2.0 M in ether) at -78 °C and stirred for 15 min. The reaction mixture was warmed to room temperature and stirred for 1 h. The reaction mixture was then quenched in HCl (2 M, 100 mL) and extracted with pentane (2 x 75 mL). The combined organic layer was washed with sat. sodium bicarbonate (75 mL), water (75 mL), and sat. sodium chloride (75 mL) then dried over magnesium sulfate. Solvent removal *in vacuo* followed by distillation gave **22** (1.89 g, 7 mmol, 70%) as a clear liquid (b.p. 105-107 °C/1.5 torr, lit. b.p. 161 °C/36 torr<sup>59</sup>). <sup>1</sup>H NMR (CDCl<sub>3</sub>) δ 1.70 (s(br), 6H, ~CH<sub>2</sub>(CH<sub>3</sub>)C=C~), 1.48 (d, *J* = 1.0 Hz, 4H, ~CH<sub>2</sub>(CH<sub>3</sub>)C=C~), 1.42-1.27 (m, 8H, ~Ge(C<sub>6</sub>H<sub>9</sub>)<sub>2</sub>), 0.91-0.84 (m, 10H, ~Ge(C<sub>6</sub>H<sub>9</sub>)<sub>2</sub>); <sup>13</sup>C NMR (CDCl<sub>3</sub>) δ 131.1, 27.7, 26.2, 23.9, 19.6, 13.9, 13.8; IR (neat,

cm<sup>-1</sup>) 2956, 2923, 2854, 1465, 1376, 1170, 842, 738, 696; GC-MS (EI): *m/z* 272 (7), 271 (5), 270 (M<sup>+</sup>, 33), 269 (11), 268 (24), 266 (19), 215 (14), 214 (9), 213 (66), 212 (22), 211 (49), 210 (6), 209 (37), 188 (11), 186 (9), 184 (7), 160 (4), 159 (22), 158 (10), 157 (100), 156 (30), 155 (79), 153 (61), 151 (5), 134 (11), 133 (8), 132 (58), 131 (33), 130 (66), 129 (27), 128 (49), 127 (17), 126 (14), 125 (5), 115 (25), 114 (8), 113 (22), 112 (4), 111 (16), 103 (15), 102 (8), 101 (21), 100 (6), 99 (17), 97 (7), 91 (10), 89 (44), 88 (12), 87 (33), 85 (24), 75 (8), 74 (20), 73 (10), 72 (14), 71 (4), 70 (11), 67 (5), 55 (8); HRMS (EI) *m/z* calcd for C<sub>14</sub>H<sub>28</sub>Ge 269.14256, found 269.16310.

**1,1-Diethyl-3,4-dimethyl-1-germacyclopent-3-ene (72).** A modification of the procedure of Takeuchi was used in the synthesis of **72**.<sup>48</sup> A solution of germanium diiodide (3.27 g, 10 mmol), 2,3-dimethyl-1,3-butadiene (1.1 g, 1.52 mL, 13 mmol), and hexane (10 mL) was sealed in a vessel and stirred for 8 h at room temperature, then heated to 50 °C for 2 h. Next the product was transferred to a flask containing ethylmagnesium bromide (40 mL, 40 mmol, 1.0 M in ether) at -78 °C and stirred for 15 min. The reaction mixture was warmed to room temperature and stirred for 1 h. The reaction mixture was then quenched in HCl (2 M, 100 mL) and extracted with pentane (2 x 75 mL). The combined organic layer was washed with sat. sodium bicarbonate (75 mL), water (75 mL), and sat. sodium chloride (75 mL) then dried over magnesium sulfate. Solvent removal in vacuo followed by distillation gave **72** (1.82 g, 8.5 mmol, 85%) as a clear liquid (b.p. 81-83 °C/1.5 torr, lit. b.p. 60 °C/7 torr<sup>59</sup>. <sup>1</sup>H NMR (CDCl<sub>3</sub>) δ 1.70 (t, *J* = 1.2 Hz, 6H, ~CH<sub>2</sub>(CH<sub>3</sub>)C=C~), 1.48 (d, *J* = 1.2 Hz, 4H, ~CH<sub>2</sub>(CH<sub>3</sub>)C=C~), 1.04 (tt, *J* = 8.1, 1.2 Hz, 6H, ~Ge(CH<sub>2</sub>CH<sub>3</sub>)<sub>2</sub>), 0.85 (qd, 8.1, 1.2 Hz, 4H, ~Ge(CH<sub>2</sub>CH<sub>3</sub>)<sub>2</sub>); <sup>13</sup>C NMR (CDCl<sub>3</sub>) δ 131.3, 23.0, 19.7, 9.4, 5.9; IR (neat, cm<sup>-1</sup>) 2950, 2906, 2871, 1455, 1376, 1170, 1020, 742, 696; GC-MS (EI): *m/z* 216 (8), 215 (5), 214 (M<sup>+</sup>, 39), 213 (13), 212 (30), 211 (4), 210 (22), 187 (21), 186 (10), 185 (100), 184 (31), 183 (75), 181 (56), 159 (16), 158 (6), 157 (76), 156 (23), 155 (66), 154 (7), 153 (48), 151 (5), 143 (4), 141 (4), 139 (5), 134 (7), 132 (31), 131 (10), 130 (23), 129 (8), 128 (20), 127 (7), 125 (5), 117 (8), 115 (34), 114 (12), 113 (32), 112 (7), 111 (24), 109 (5), 106 (5), 105 (17), 104 (24), 103 (76), 102 (36), 101 (67), 100 (20), 99 (52), 97 (11), 91 (7), 89 (26), 88

(9), 87 (21), 85 (14), 77 (7), 75 (21), 74 (15), 73 (17), 72 (8), 71 (11), 70 (6), 67 (9), 53 (5); HRMS (EI)  $m/z$  calcd for  $C_{14}H_{28}Ge$  213.07996, found 213.08044.

**1,1,3,4-Tetramethyl-1-germacyclopent-3-ene (38).** This compound was made according to the literature.<sup>48</sup> A solution of germanium diiodide (3.27 g, 10 mmol), 2,3-dimethyl-1,3-butadiene (1.1 g, 1.52 mL, 13 mmol), and hexane (10 mL) was sealed in a vessel and stirred for 8 h at room temperature, then heated to 60 °C for 4 h. Next the product was transferred to a flask containing methylmagnesium chloride (20 mL, 60 mmol, 3.0 M in ether) at -78 °C and stirred for 15 min. The reaction mixture was warmed to room temperature and stirred for 2 h. The reaction mixture was then quenched in HCl (2 M, 100 mL) and extracted with pentane (2 x 75 mL). The combined organic layer was washed with sat. sodium bicarbonate (75 mL), water (75 mL), and sat. sodium chloride (75 mL) then dried over magnesium sulfate. Solvent removal *in vacuo* followed by distillation gave **32** (1.8 g, 9.7 mmol, 97%) as a clear liquid (b.p. 51-53 °C/8 torr, lit. b.p. 88 °C/45 torr<sup>48</sup>). <sup>1</sup>H NMR ( $CDCl_3$ )  $\delta$  1.71 (t,  $J = 1.0$  Hz, 6H,  $\sim CH_2(CH_3)C=C\sim$ ), 1.52 (d,  $J = 1.0$  Hz, 4H,  $\sim CH_2(CH_3)C=C\sim$ ), 0.30 (s, 6H,  $\sim Ge(CH_3)_2$ ); <sup>13</sup>C NMR ( $CDCl_3$ )  $\delta$  130.9, 26.9, 19.4, -2.2; IR (neat,  $cm^{-1}$ ) 2986, 2905, 1820, 1446, 1385, 1248, 1167, 942, 892, 830, 796; GC-MS (EI):  $m/z$  188 (11), 187 (5), 186 ( $M^+$ , 55), 184 (42), 182 (31), 173 (21), 172 (8), 171 (100), 170 (28), 169 (76), 167 (57), 143 (8), 141 (6), 139 (5), 129 (12), 127 (10), 125 (7), 115 (5), 113 (7), 111 (5), 106 (9), 105 (7), 104 (43), 103 (16), 102 (32), 101 (8), 100 (25), 99 (5), 97 (4), 91 (14), 89 (64), 88 (17), 85 (37), 75 (4), 73 (4), 67 (4); HRMS (EI)  $m/z$  calcd for  $C_8H_{16}Ge$  185.04866, found 185.04898.

**1,1-Dichloro-3,4-dimethyl-1-germacyclopent-3-ene (69).** This compound was made according to the literature.<sup>60</sup> Synthesized according to the method of Mazerolles et al. A solution of germanium diiodide (11.86 g, 36.3 mmol), 2,3-dimethyl-1,3-butadiene (3.66 g, 5.04 mL, 44.6 mmol), and hexane (50 mL) was stirred at room temperature for 8 h in a sealed vessel, then heated to 60 °C for 2 h. Upon completion the reaction mixture was added to sodium hydroxide (7.8 g, 195 mmol) and water (38 mL) in a round bottom flask. The solvent was then removed *in vacuo* and the aqueous solution and precipitate transferred to a beaker. The

solution was neutralized by the addition of HCl (3 M, approximately 42 mL). The resulting white precipitate was isolated by filtration, then shaken with conc. HCl (40 mL). This solution was extracted with pentane (2 x 100 mL), and the combined organic layers dried over calcium chloride. Solvent removal *in vacuo* followed by distillation gave **69** (5.97 g, 26.3 mmol, 65%) as a clear liquid (b.p. 65–68 °C/1.5 torr, lit. b.p. 90 °C/12 torr<sup>60</sup>). <sup>1</sup>H NMR (CDCl<sub>3</sub>) δ 2.23 (d, *J* = 1.2 Hz, 4H, ~CH<sub>2</sub>(CH<sub>3</sub>)C=C~), 1.78 (t, *J* = 1.2 Hz, 6H, ~CH<sub>2</sub>(CH<sub>3</sub>)C=C~); <sup>13</sup>C NMR (CDCl<sub>3</sub>) δ 129.2, 33.0, 18.8; IR (neat, cm<sup>-1</sup>) 2986, 2913, 2858, 1640, 1444, 1395, 1167, 1109, 975, 755, 695; GC-MS (EI): *m/z* 228 (4), 226 (M<sup>+</sup>, 7), 224 (5), 146 (4), 144 (7), 142 (5), 111 (9), 109 (19), 108 (4), 107 (14), 105 (8), 83 (7), 82 (100), 81 (13), 79 (6), 68 (6), 67 (95), 65 (8), 54 (18), 53 (9), 51 (4); HRMS (EI) *m/z* calcd for C<sub>6</sub>H<sub>10</sub>GeCl<sub>2</sub> 224.93942, found 224.93977.

**Dihexylbis(trimethylsilyl)germane (44).** A flask containing dry THF (200 mL) and lithium wire (2.62 g, 380 mmol) was cooled to 0 °C under argon. Next, freshly distilled trimethylchlorosilane (25.9 g, 30.2 mL, 240 mmol) was added and allowed to stir for 15 min. The reaction was then warmed to room temperature and stirred for 2 h. A solution of dihexyldichlorogermane (**43**) (18.84 g, 60 mmol) in dry THF (50 mL) was added over 2 h at 0 °C then warmed to room temperature and stirred overnight. Next the remaining lithium was removed by filtration through celite. The reaction mixture was then quenched in HCl (2 M, 200 mL) and extracted with pentane (2 x 150 mL). The organic layer was washed with sat. sodium bicarbonate (100 mL), water (100 mL), sat. sodium chloride (100 mL), then dried over magnesium sulfate. Solvent removal *in vacuo* followed by distillation provided **44** (13 g, 33 mmol, 56%) as a clear liquid (b.p. 121–125 °C/2 torr). <sup>1</sup>H NMR (CDCl<sub>3</sub>) δ 1.44–1.23 (m, 16H, ~Ge(C<sub>6</sub>H<sub>13</sub>)<sub>2</sub>), 0.90–0.85 (m, 10H, ~Ge(C<sub>6</sub>H<sub>13</sub>)<sub>2</sub>), 0.16 (s, 18H, ~Si(CH<sub>3</sub>)<sub>3</sub>); <sup>13</sup>C NMR (CDCl<sub>3</sub>) δ 33.8, 31.6, 28.3, 22.7, 14.2, 11.2, 0.6; IR (neat, cm<sup>-1</sup>) 2956, 2923, 2852, 1466, 1244, 834, 688, 619; GC-MS (EI): *m/z* 390 (M<sup>+</sup>, 6), 389 (3), 388 (4), 386 (3), 305 (12), 304 (4), 303 (8), 301 (6), 235 (7), 234 (5), 233 (29), 232 (10), 231 (22), 229 (16), 224 (4), 223 (27), 222 (18), 221 (100), 220 (33), 219 (73), 218 (10), 217 (53), 207 (14), 159 (4), 158 (9), 157 (6), 156 (9), 154 (5), 151 (7), 149

(33), 148 (11), 147 (46), 146 (10), 145 (37), 144 (4), 143 (15), 133 (6), 132 (5), 131 (16), 130 (4), 129 (6), 117 (6), 115 (4), 89 (8), 87 (7), 85 (6), 75 (4), 74 (8), 73 (100), 59 (30); HRMS (EI)  $m/z$  calcd for  $C_{18}H_{44}GeSi_2$  390.219618, found 390.220350.

**Dihexyl(trimethylsilyl)germane (45).** To a stirring solution of dihexylbis(trimethylsilyl)germane (**44**) (9.0 g, 23.1 mmol) in dry THF (100 mL) was added methyllithium (16.5 mL, 23.1 mmol, 1.4 M in ether) at room temperature. The reaction mixture was stirred at room temperature for 6 days, monitored by GC. When the reaction was complete it was quenched in dilute HCl (150 mL) and extracted with pentane (2 x 100 mL), then dried over magnesium sulfate. Solvent removal *in vacuo* followed by distillation provided **45** (5.0 g, 15.7 mmol, 67%) as a clear liquid (b.p. 93-95 °C/1.5 torr).  $^1H$  NMR ( $C_6D_6$ )  $\delta$  3.25 (quintet,  $J = 3.6$  Hz, 1H,  $\sim GeH$ ), 1.48-1.15 (m, 16H,  $\sim Ge(C_6H_{13})_2$ ), 0.91-0.85 (m, 10H,  $\sim Ge(C_6H_{13})_2$ ), 0.18 (s, 9H,  $\sim Si(CH_3)_3$ );  $^{13}C$  NMR ( $C_6D_6$ )  $\delta$  33.0, 31.6, 27.9, 27.7, 14.2, 11.0, -0.1; IR (neat,  $cm^{-1}$ ) 2956, 2924, 2852, 1980, 1465, 1245, 995, 960, 836, 749, 692, 618; GC-MS (EI):  $m/z$  246 (6), 245 (5), 244 ( $[M-HSiMe_3]^+$ , 29), 243 (9), 242 (22), 241 (1), 240 (16), 162 (15), 161 (14), 160 (75), 159 (44), 158 (83), 157 (29), 156 (59), 155 (14), 154 (14), 151 (5), 149 (24), 148 (7), 147 (22), 146 (4), 145 (25), 144 (4), 143 (11), 141 (6), 135 (5), 134 (5), 133 (9), 132 (8), 131 (16), 130 (19), 129 (11), 128 (14), 127 (6), 118 (8), 117 (9), 116 (12), 115 (9), 114 (9), 113 (6), 105 (6), 103 (12), 102 (4), 101 (10), 99 (7), 91 (6), 89 (22), 88 (6), 87 (17), 85 (16), 84 (4), 83 (42), 75 (8), 74 (14), 73 (100), 72 (6), 71 (4), 70 (4), 59 (29), 57 (5), 56 (4), 55 (18).

**Flow pyrolysis of dihexyl(trimethylsilyl)germane (45) over a germanium surface.** A solution of **45** (0.109 g, 0.3427 mmol), heptane (0.066 mg), and octane (3 mL) was added by syringe over 15 min through a 50 cm vertical quartz tube packed with quartz chips at 300 °C with a flow rate of 60 mL/min (He). The column surface had been coated with Ge/C by CVD. The pyrolysate was collected in a flask at -116 °C in an ethanol/ $N_2$  bath. Conversion was 66% based on the remaining starting material. The following volatile products were observed (identified based on MS and comparison to known compounds, yields were determined by the internal standard method using appropriate Rfs and are total yields based on 100%

conversion): 1-hexene (22.1 mg, 0.2625 mmol, 38.3%), *trans*-2-hexene (8.3 mg, 0.0992 mmol, 14.5%), *trans*-3-hexene (3.4 mg, 0.0407 mmol, 5.9%), and trimethylsilane (7.0 mg, 0.095 mmol, 28.0%). Total yield of C<sub>6</sub> hydrocarbons was 58.7%.

**Flow pyrolysis of dihexyl(trimethylsilyl)germane (45) in the presence of isoprene over a germanium surface.** A solution of **45** (0.100 g, 0.318 mmol) isoprene (3 mL) was added by syringe over 15 min through a 50 cm vertical quartz tube packed with quartz chips at 300 °C with a flow rate of 60 mL/min (He). The column surface had been coated with Ge/C by CVD. The pyrolysate was collected in a flask at -116 °C in an ethanol/N<sub>2</sub> bath. Conversion estimated at 70% based on the remaining starting material. The following volatile products were observed (identified based on MS and comparison to known compounds, yields were determined by the internal standard method using appropriate Rfs and are total yields based on 100% conversion): 1-hexene (48.3 mg, 0.57463 mmol, 47.4%), *trans*-2-hexene (10.4 mg, 0.123941 mmol, 10.2%), *trans*-3-hexene (4.7 mg, 0.055391 mmol, 4.6%), and hexane (7.0 mg, 0.081237 mmol, 6.7%). Total C<sub>6</sub> hydrocarbon yield was 68.9%.

**Hexyltrichlorogermane (47).** A modification of the procedure of Poskozim was used in the synthesis of **47**.<sup>61</sup> Flask was fitted with reflux condenser and stirbar, then charged with cesium trichlorogermanate **41** (10 g, 32 mmol), *n*-hexyl iodide (8.48 g, 5.9 mL, 40 mmol) and THF (20 mL). The reaction mixture was carried out under argon flow in the dark. The reaction was heated in a 150 °C oil bath for 6 days, then extracted with pentane (2 x 100 mL). After solvent removal *in vacuo*, the product was distilled at reduced pressure to give **47** (6 g, 22.7 mmol, 71%) as a clear liquid (b.p. 62-65 °C/1.5 torr, lit. b.p. 97 °C/14 torr<sup>62</sup>). <sup>1</sup>H NMR (CDCl<sub>3</sub>) δ 2.06 (m, 2H), 1.74 (m, 2H), 1.48(m, 2H), 1.3 (m, 4H), 0.90 (m, 3H); <sup>13</sup>C NMR (CDCl<sub>3</sub>) δ 33.0, 31.1, 30.7, 23.1, 22.4, 14.1; IR (neat, cm<sup>-1</sup>) 2958, 2930, 2860, 1459, 1401, 1379, 1176, 1105, 965, 699; GC-MS (EI): *m/z* 230 ([M-Cl]<sup>+</sup>, 10), 229 (6), 227 (5), 226 (11), 224 (6), 194 (19), 193 (6), 192 (43), 191 (11), 190 (33), 188 (20), 183 (9), 181 (20), 179 (25), 177 (17), 175 (8), 144 (6), 109 (20), 107 (15), 105 (9), 85 (54), 84



(100), 83 (25), 69 (29), 57 (71), 56 (75), 55 (68), 54 (7), 53 (7); HRMS (EI)  $m/z$  calcd for  $C_6H_{13}GeCl_3$  263.928368, found 263.928970.

**Hexylgermane (48).** This compound was made according to the literature.<sup>63</sup> A solution of lithium aluminum hydride (15 mL, 15 mmol, 1 M in ether) and dry THF (50 mL) was cooled to  $-78\text{ }^\circ\text{C}$ . Hexyltrichlorogermane (**47**) (3 g, 11.36 mmol) was added slowly, then the solution was allowed to stir for 30 min. The reaction mixture was then warmed to room temperature and stirred for 2 h. The reaction mixture was quenched in chilled water (100 mL) and extracted with pentane (2 x 75 mL). The combined organic fraction was washed with water (75 mL), sat. sodium chloride (75 mL) and water (75 mL) then dried over magnesium sulfate. After solvent removal *in vacuo*, distillation provided **48** (1.33 g, 8.21 mmol, 72%) as a clear liquid (b.p. 128-129  $^\circ\text{C}$ , lit. b.p. 128-129  $^\circ\text{C}$ <sup>64</sup>).  $^1\text{H}$  NMR ( $C_6D_6$ )  $\delta$  3.54 (t,  $J = 3.0$  Hz, 3H,  $\sim\text{GeH}_3$ ), 1.32-1.13 (m, 8H), 0.85-0.76 (m, 5H);  $^{13}\text{C}$  NMR ( $C_6D_6$ )  $\delta$  32.0, 31.5, 27.9, 22.6, 14.1, 8.1; IR (neat,  $\text{cm}^{-1}$ ) 2957, 2922, 2854, 2064, 1465, 1378, 1060, 881, 830, 710, 673, 617, 548; GC-MS (EI):  $m/z$  162 ( $M^+$ , 2), 161 (4), 160 (7), 159 (4), 158 (6), 157 (3), 156 (4), 134 (5), 133 (7), 132 (9), 131 (5), 130 (7), 129 (5), 128 (4), 119 (7), 118 (4), 117 (7), 116 (4), 115 (5), 107 (19), 106 (5), 105 (100), 104 (36), 103 (95), 102 (17), 101 (70), 100 (9), 99 (12), 91 (7), 89 (14), 88 (5), 87 (11), 84 (25), 83 (27), 77 (32), 76 (12), 75 (37), 74 (23), 73 (31), 72 (15), 71 (19), 70 (10), 69 (8), 57 (38), 56 (32), 55 (42), 53 (6); HRMS (EI)  $m/z$  calcd for  $C_6H_{16}Ge$  162.046468, found 162.046660.

**Flash vacuum pyrolysis of hexylgermane (48) over a germanium surface.** Flash vacuum pyrolysis was carried out on hexylgermane (**48**) (0.200 g, 1.23 mmol) using a 50 cm quartz tube packed with quartz chips at 490  $^\circ\text{C}$ . Pressure was maintained below  $2.5 \times 10^{-5}$  torr during the pyrolysis. The column surface had been coated with Ge/C by CVD. Pyrolysate was collected in a  $N_2$  trap and analyzed by GC-MS, yields determined using GC standard techniques. The conversion was 95% based on the remaining starting material (10 mg, 0.0617 mmol). The volatile products were: 1-hexene (34.8 mg, 0.413931 mmol, 33.7%), *trans*-2-hexene (3.5 mg, .027186 mmol, 2.2%), *trans*-3-hexene (1.2 mg, 0.014276 mmol, 1.2%), hexane

(trace). Total yield of hexenes was 41%. The remainder of the volatile component was made up of hexadienes and benzene (55 mg).

**Flow pyrolysis of hexylgermane (48) over a germanium surface.** A solution of **48** (0.100 g, 0.606 mmol), heptane (0.068 g), and toluene (3 mL) was added by syringe over 15 min through a 50 cm vertical quartz tube packed with quartz chips at 400 °C with a flow rate of 60 mL/min (He). The column surface had been coated with Ge/C by CVD. The pyrolysate was collected in a flask at -116 °C in an ethanol/N<sub>2</sub> bath. Conversion was 83.9% based on the remaining starting material. The following volatile products were observed (identified based on MS and comparison to known compounds, yields were determined by the internal standard method using appropriate Rfs and are total yields based on 100% conversion): 1-hexene (48.3 mg, 0.57463 mmol, 47.4%), *trans*-2-hexene (10.4 mg, 0.123941 mmol, 10.2%), *trans*-3-hexene (4.7 mg, 0.055391 mmol, 4.6%), and hexane (7.0 mg, 0.081237 mmol, 6.7%). Total C6 hydrocarbon yield was 68.9%.

**Hexylgermane-d<sub>3</sub> (48D).** A dry flask was flushed with argon and charged with lithium aluminum deuteride (0.75 g, 18 mmol) and dry ether (50 mL), then cooled to -78 °C. Hexyltrichlorogermane (**47**) (2.75 g, 10.4 mmol) was added slowly over 30 min with stirring. The reaction mixture was then allowed to warm to room temperature and stir for 2 h. The reaction mixture was quenched in chilled water (100 mL) and extracted with pentane (2 x 75 mL). The combined organic fraction was washed with water (75 mL), sat. sodium chloride (75 mL), and water (75 mL), then dried over magnesium sulfate. After solvent removal *in vacuo*, distillation provided **48D** (1.32 g, 8.0 mmol, 77%) as a clear liquid (b.p. 128-129 °C). <sup>1</sup>H NMR (C<sub>6</sub>D<sub>6</sub>) δ 1.66 (m, 2H), 1.29(m, 6H), 1.01(t(br), *J* = 7.7 Hz, 2H), 0.88, (m,3H); <sup>13</sup>C NMR (C<sub>6</sub>D<sub>6</sub>) δ 32.0, 31.5, 27.9, 22.6, 14.2, 7.8; IR (neat, cm<sup>-1</sup>) 2957, 2921, 2854, 1489, 1101, 1019, 962, 804, 628; GC-MS (EI): *m/z* 165 (M<sup>+</sup>, 3), 164 (2), 163 (5), 162 (4), 161 (6), 160 (3), 159 (4), 158 (2), 157 (2), 137 (8), 136 (5), 135 (10), 134 (5), 133 (10), 132 (5), 131 (5), 110 (21), 109 (7), 108 (100), 107 (44), 106 (93), 105 (30), 104 (72), 103 (21), 102 (14), 101 (9), 100 (4), 92 (4), 91 (5), 90 (6), 89 (8), 88 (7), 87 (11), 86 (31), 85 (25), 84 (14), 83 (5), 82 (4), 81 (3), 80 (18), 79 (18), 77 (20), 76

(33), 75 (21), 74 (34), 73 (14), 72 (19), 71 (6), 70 (12), 69 (5), 58 (16), 57 (19), 56 (19), 55 (22); HRMS (EI)  $m/z$  calcd for  $C_6H_{13}D_3Ge$  165.065209, found 165.065329.

**Flash vacuum pyrolysis of hexylgermane- $d_3$  (48D) over a germanium surface.** Flash vacuum pyrolysis was carried out on hexylgermane- $d_3$  (**48D**) (0.200 g, 1.2121 mmol) using a 50 cm quartz tube packed with quartz chips at 470 °C. Pressure was maintained below  $2.5 \times 10^{-5}$  torr during the pyrolysis. The column surface had been coated with Ge/C by CVD. Pyrolysate was collected in a  $N_2$  trap and analyzed by GC-MS, yields determined using GC standard techniques. The conversion was 70% based on the remaining starting material (60 mg, 0.3636 mmol). The volatile products were: 1-hexene (44.6 mg, 0.530579 mmol, 43.8%), *trans*-2-hexene (3.07 mg, .036519 mmol, 3%), *trans*-3-hexene (1.71 mg, 0.020306 mmol, 1.7%), hexane (2.07 mg, 0.024094 mmol, 2%). Total yield of  $C_6$  hydrocarbons was 50.5%. The remainder of the volatile component was made up of hexadienes and benzene (30.6 mg). Deuterium incorporation was calculated to be 1-hexene (8%), *trans*-2-hexene (33%), *trans*-3-hexene (29%), hexane (48%) based on mass spectral analysis.

**Flow pyrolysis of hexylgermane- $d_3$  (48D) over a germanium surface.** A solution of **48D** (0.106 g, 0.642 mmol), octane (0.064 g), and toluene (3 mL) was added by syringe over 15 min through a 50 cm vertical quartz tube packed with quartz chips at 400 °C with a flow rate of 60 mL/min (He). The column surface had been coated with Ge/C by CVD. The pyrolysate was collected in a flask at -116 °C in an ethanol/ $N_2$  bath. Conversion was 79% based on the remaining starting material. The following volatile products were observed (identified based on MS and comparison to known compounds, yields were determined by the internal standard method using appropriate Rfs and are total yields based on 100% conversion): 1-hexene (54.4 mg, 0.6480 mmol, 50.4%), *trans*-2-hexene (7.7 mg, 0.092095 mmol, 7.2%), *trans*-3-hexene (3.7 mg, 0.043583 mmol, 3.4%), and hexane (5.8 mg, 0.06731 mmol, 5.2%). Total  $C_6$  hydrocarbon yield was 66.2%. Deuterium

incorporation was calculated to be 1-hexene (12%), *trans*-2-hexene (35%), *trans*-3-hexene (28%), hexane (68%) based on mass spectral analysis.

**Dihexyldichlorogermane (43).** This compound was made according to a modification of a literature procedure.<sup>49</sup> A flask was fitted with a reflux condenser, stirbar and charged with tetrahexylgermane (**42**) (10 g, 24.4 mmol) and 0.2 equivalents of aluminum chloride (0.66 g, 4.9 mmol). The reaction vessel was well flushed with argon, then heated to 85 °C. Next, 1.95 equivalents of 2-chloropropane (3.705 g, 4.3 mL, 47.6 mmol) was added carefully dropwise by syringe. Upon completion the reaction mixture was stirred at 85 °C for 1.5 h. Solvent removal *in vacuo* followed by vacuum distillation gave **43** (6.8 g, 21.7 mmol, 88%) as a clear liquid (b.p. 105-110 °C/1.5 torr, lit. b.p. 130-138 °C/2.6 torr<sup>65</sup>). <sup>1</sup>H NMR (CDCl<sub>3</sub>) δ 1.60 (m, 4H), 1.32 (m, 12H), 0.89 (m, 10H); <sup>13</sup>C NMR (CDCl<sub>3</sub>) δ 31.6, 31.3, 29.2, 23.3, 22.5, 14.1; IR (neat, cm<sup>-1</sup>) 2956, 2858, 1465, 1378, 1175, 1104, 963, 694; GC-MS (EI): *m/z* 316 (2), 314 (M<sup>+</sup>, 4), 312 (2), 310 (1), 280 (7), 278 (18), 277 (6), 276 (11), 274 (6), 231 (22), 230 (6), 229 (33), 227 (24), 225 (10), 196 (31), 195 (18), 194 (74), 193 (37), 192 (59), 191 (22), 190 (35), 189 (22), 187 (23), 185 (16), 111 (11), 109 (24), 107 (18), 105 (9), 85 (100), 84 (11), 57 (35), 56 (19), 55 (24); HRMS (EI) *m/z* calcd for C<sub>12</sub>H<sub>26</sub>GeCl<sub>2</sub> 314.061651, found 314.061951.

**Dihexylgermane (49).** This compound was made according to the literature.<sup>66</sup> A flask was charged with dry THF (150 mL) and dihexyldichlorogermane (**43**) (6.8 g, 22 mmol) and cooled to -78 °C. Next, lithium aluminum hydride (22 mL, 22 mmol, 1 M in ether) was added by an addition funnel over 1 h. Upon completion the reaction mixture was warmed to room temperature and stirred for 2 h. The reaction mixture was quenched in water (150 mL) and extracted with pentane (2 x 75 mL). The combined organic fraction was washed with water (100 mL), sodium chloride (100 mL), and water (100 mL) then dried over magnesium sulfate. After solvent removal *in vacuo*, vacuum distillation provided **49** (5 g, 20.3 mmol, 94%) as a clear liquid (b.p. 75-77 °C/1 torr, lit. b.p. 113-114 °C/8 torr<sup>64</sup>). <sup>1</sup>H NMR (C<sub>6</sub>D<sub>6</sub>) δ 3.93 (quintet, *J* = 3.0 Hz, 2H, ~GeH<sub>2</sub>), 1.48 (m, 4H), 1.35 (m, 16H), 0.91 (m, 6H); <sup>13</sup>C NMR (C<sub>6</sub>D<sub>6</sub>) 33.1, 32.2, 27.8, 23.3, 14.7, 11.2; IR (neat, cm<sup>-1</sup>) 2957, 2926, 2853,

2034, 1464, 1377, 1295, 1171, 960, 872, 750, 631, 564; GC-MS (EI):  $m/z$  246 ( $M^+$ , 1), 245 (1), 244 (2), 243 (1), 242 (1), 241 (1), 163 (16), 162 (13), 161 (78), 160 (60), 159 (70), 158 (48), 156 (28), 154 (5), 145 (11), 133 (13), 132 (21), 131 (17), 130 (18), 129 (12), 128 (13), 119 (12), 118 (10), 117 (14), 116 (8), 115 (11), 105 (36), 104 (11), 103 (37), 102 (7), 101 (29), 99 (8), 91 (10), 89 (17), 88 (5), 87 (13), 85 (11), 84 (10), 83 (100), 75 (12), 74 (16), 73 (12), 72 (11), 70 (9), 57 (8), 56 (8), 55 (44); HRMS (EI)  $m/z$  calcd for  $C_{12}H_{28}Ge$  246.140495, found 246.141014.

**Flow pyrolysis of dihexylgermane (49) over a germanium surface.** A solution of **49** (0.0886 g, 0.357 mmol, octane (0.0876 g), and toluene (3 mL) was added by syringe over 15 min through a 50 cm vertical quartz tube packed with quartz chips at 410 °C with a flow rate of 60 mL/min (He). The column surface had been coated with Ge/C by CVD. The pyrolysate was collected in a flask at -116 °C in an ethanol/ $N_2$  bath. Conversion was 97.4% based on the remaining starting material. The following volatile products were observed (identified based on MS and comparison to known compounds, yields were determined by the internal standard method using appropriate Rfs and are total yields based on 100% conversion): 1-hexene (28.7 mg, 0.341107 mmol, 47.7%), *trans*-2-hexene (10.8 mg, 0.128046 mmol, 17.9%), *trans*-3-hexene (5.7 mg, 0.067721 mmol, 9.5%), and hexane (2.7 mg, 0.031751 mmol, 4.4%). Total yield of  $C_6$  hydrocarbons was 79.5%.

**Dihexylgermane- $d_2$  (49D).** A flask was charged with lithium aluminum deuteride (0.536 g, 12.76 mmol) and of dry THF (13mL), then cooled to -78 °C. Next, dihexyldichlorogermane (**43**) (4.0 g, 12.76 mmol) was added slowly with stirring over 1 h. The reaction mixture was warmed to room temperature and stirred for 2 h. The reaction mixture was quenched in water (50 mL), then extracted with pentane (2 x 50 mL). The combined organic fraction was washed with water (50 mL), sat. sodium chloride (50 mL) and water (50 mL), then dried over magnesium sulfate. After solvent removal *in vacuo*, vacuum distillation provided **49D** (3.0 g, 12.1 mmol, 95%) as a clear liquid (b.p. 73-75 °C/1.5 torr).  $^1H$  NMR ( $C_6D_6$ )  $\delta$  1.52 (m, 4H), 1.32 (m, 12H), 0.96 (m, 10H);  $^{13}C$  NMR ( $C_6D_6$ )  $\delta$  32.4, 31.6, 27.1, 22.7, 14.2, 10.3; IR (neat,  $cm^{-1}$ ) 2956, 2922, 2853, 1465, 1377, 1171, 960, 843, 696, 624, 524; GC-

MS (EI):  $m/z$  248 ( $M^+$ , 1), 247 (1), 246 (1), 245 (2), 244 (2), 243 (1), 242 (1), 241 (1), 165 (19), 164 (7), 163 (96), 162 (31), 161 (100), 160 (10), 159 (82), 158 (11), 157 (23), 146 (8), 144 (7), 135 (9), 134 (10), 133 (19), 132 (14), 131 (17), 130 (10), 129 (10), 120 (8), 119 (11), 118 (9), 117 (10), 116 (8), 107 (21), 106 (23), 105 (27), 104 (21), 103 (22), 102 (16), 101 (9), 100 (5), 90 (8), 89 (11), 88 (7), 87 (8), 86 (6), 85 (31), 84 (55), 83 (22), 79 (5), 78 (6), 77 (7), 76 (9), 75 (9), 74 (18), 73 (8), 72 (11), 70 (9), 56 (16), 55 (32); HRMS (EI)  $m/z$  calcd for  $C_{12}H_{26}D_2Ge$  248.152832, found 248.152908.

**Flow pyrolysis of dihexylgermane- $d_2$  (49D) over a germanium surface.** A solution of **49D** (0.039 g, 0.157 mmol, *p*-xylene (0.044 g), and toluene (3 mL) was added by syringe over 15 min through a 50 cm vertical quartz tube packed with quartz chips at 375 °C with a flow rate of 60 mL/min (He). The column had been coated with Ge/C by CVD. The pyrolysate was collected in a flask at -116 °C in an ethanol/ $N_2$  bath. Conversion was 86% based on the remaining starting material. The following volatile products were observed (identified based on MS and comparison to known compounds, yields were determined by the internal standard method using appropriate Rfs and are total yields based on 100% conversion): 1-hexene (14.8 mg, 0.1767 mmol, 56.3%), *trans*-2-hexene (4.4 mg, 0.05325 mmol, 16.9%), *trans*-3-hexene (2.1 mg, 0.025638 mmol, 8.2%), and hexane (1.3 mg, 0.015176 mmol, 4.8%). Total yield of  $C_6$  hydrocarbons was 86%. Deuterium incorporation was calculated to be 1-hexene (9%), *trans*-2-hexene (20%), *trans*-3-hexene (20%), hexane (13%) base on mass spectral analysis.

**Flow pyrolysis of dihexylgermane- $d_2$  (49D) over a silica surface.** A solution of **49D** (0.067 g, 0.270 mmol, *p*-xylene (0.046 g), and toluene (3 mL) was added by syringe over 15 min through a 50 cm vertical quartz tube packed with quartz chips at 425 °C with a flow rate of 60 mL/min (He). The pyrolysate was collected in a flask at -116 °C in an ethanol/ $N_2$  bath. Conversion was 70.3% based on the remaining starting material. The following volatile products were observed (identified based on MS and comparison to known compounds, yields were determined by the internal standard method using appropriate Rfs and are total

yields based on 100% conversion): 1-hexene (8.9 mg, 0.1064 mmol, 19.7%), *trans*-2-hexene (14.9 mg, 0.1779 mmol, 32.9%), *trans*-3-hexene (6.8 mg, 0.0821 mmol, 15.1%), and hexane (1.1 mg, 0.01292 mmol, 2.4%). Total yield of C<sub>6</sub> hydrocarbons was 70%. Deuterium incorporation was calculated to be 1-hexene (20%), *trans*-2-hexene (26%), *trans*-3-hexene (26%), hexane (28%) base on mass spectral analysis.

**Trihexylchlorogermane (50).** Method 1. The method of Mironov<sup>49</sup> was used. A flask was fitted with a reflux condenser, stirbar and charged with tetrahexylgermane (**42**) (12.42 g, 30 mmol) and 0.02 equivalents of aluminum chloride (0.089 g, 0.675 mmol). The reaction vessel was well flushed with argon, then heated to 85 °C. Next, 1 equivalent of 2-chloropropane (2.34 g, 2.72 mL 30 mmol) was added carefully dropwise by syringe. Upon completion the reaction mixture was stirred at 85 °C for 3 h. After solvent removal *in vacuo*, the product was isolated by vacuum distillation giving **50** (6.8 g, 21.7 mmol, 88%) as a clear liquid (b.p. 105-110 °C/1.5 torr, lit. b.p. 130-138 °C/2.6 torr<sup>65</sup>).

Method 2: This compound was made by a modification of a literature procedure.<sup>50</sup> A solution of tetrahexylgermane (**42**) (1.332 g, 3.2 mmol) in dry nitromethane (50 mL) and tin(IV)chloride (0.92 g, 0.41 mL, 3.54 mmol) was refluxed for 4 h with stirring under argon. The reaction mixture was then allowed to cool. Two layers formed, the top organic layer was recovered and the remainder extracted with pentane (50 mL). The product was distilled after solvent removal *in vacuo*. Vacuum distillation gave **50** (0.89 g, 2.4 mmol, 75%) as a clear liquid (b.p. 80 °C/10 torr, lit. b.p. 138-139 °C/0.5 torr<sup>67</sup>).

**50** <sup>1</sup>H NMR (CDCl<sub>3</sub>) δ 1.34 (m, 8H), 1.26 (m, 24H), 1.1 (m, 8H), 0.86 (m, 12H); <sup>13</sup>C NMR (CDCl<sub>3</sub>) 32.7, 31.6, 24.2, 22.8, 19.3, 14.3; IR (neat, cm<sup>-1</sup>) 2956, 2925, 2855, 1465, 1377, 1171, 1102, 962, 693; MS (CI/NH<sub>3</sub>): *m/z* 382 ([M+NH<sub>4</sub>]<sup>+</sup>, 10), 380 (8), 378 (6), 348 (6), 346 (29), 345 (13), 344 (25), 342 (19), 298 (40), 297 (31), 296 (100), 295 (57), 294 (74), 293 (29), 292 (42), 291 (16), 214 (16), 213 (6), 212 (42), 211 (14), 210 (28), 209 (6), 208 (17), 109 (8), 107 (7).

**Trihexylgermane (51).** This compound was made according to the literature procedure.<sup>66</sup> A solution of lithium aluminum hydride (3.04 mL, 3.04 mmol 1.0 M in ether) was cooled to  $-78\text{ }^{\circ}\text{C}$ . Trihexylchlorogermane (**50**) (1.11 g, 3.04 mmol) was added slowly. Upon completion, the reaction mixture was stirred for 30 min and then warmed to room temperature and stirred for 1.5 h. The reaction mixture was then carefully quenched in water (50 mL) and extracted with hexane (2 x 50 mL). The organic portion was washed with water (50 mL), sat. sodium chloride (50 mL), and water (50 mL), then dried over magnesium sulfate. After solvent removal *in vacuo*, purification by flash chromatography (hexane, silica gel) provided **51** (0.93 g, 2.8 mmol, 93%) as a clear liquid (lit. b.p.  $169\text{-}170\text{ }^{\circ}\text{C}/9\text{ torr}^{67}$ ).  $^1\text{H}$  NMR ( $\text{C}_6\text{D}_6$ )  $\delta$  4.07 (septet,  $J = 3.0\text{ Hz}$ , 1H,  $\sim\text{GeH}$ ), 1.52 (m, 8H), 1.35 (m, 24H), 0.92 (m, 20H);  $^{13}\text{C}$  NMR ( $\text{C}_6\text{D}_6$ ) 33.7, 32.3, 27.1, 23.4, 14.7, 13.0; IR (neat,  $\text{cm}^{-1}$ ) 2957, 2920, 2852, 2005, 1465, 1377, 1260, 1169, 1100, 1021, 961, 794, 723; GC-MS (EI):  $m/z$  329 ( $[\text{M-H}]^+$ , 1), 281 (31), 280 (15), 279 (76), 278 (22), 277 (57), 275 (35), 197 (42), 196 (15), 195 (100), 194 (28), 193 (79), 192 (8), 191 (48), 159 (18), 158 (6), 157 (16), 155 (20), 153 (23), 151 (17), 149 (10), 139 (13), 137 (13), 133 (9), 131 (7), 129 (7), 127 (6), 113 (6), 111 (14), 109 (27), 107 (20), 105 (14), 103 (7), 101 (7), 85 (30), 83 (54), 57 (16), 56 (6), 55 (29); HRMS (EI)  $m/z$  calcd for  $\text{C}_{18}\text{H}_{40}\text{Ge}$  330.234539, found 330.234958.

**Flow pyrolysis of trihexylgermane (51) over a germanium surface.** A solution of **51** (0.112 g, 0.339 mmol), heptane (0.070 g), and toluene (3 mL) was added by syringe over 15 min through a 50 cm vertical quartz tube packed with quartz chips at  $450\text{ }^{\circ}\text{C}$  with a flow rate of 60 mL/min (He). The column surface had been coated with Ge/C by CVD. The pyrolysate was collected in a flask at  $-116\text{ }^{\circ}\text{C}$  in an ethanol/ $\text{N}_2$  bath. Conversion was 54.7% based on the remaining starting material. The following volatile products were observed (identified based on MS and comparison to known compounds, yields were determined by the internal standard method using appropriate Rfs and are total yields based on 100% conversion): 1-hexene (21.5 mg, 0.2557 mmol, 25%), *trans*-2-hexene (10.2 mg, 0.1210 mmol,



12%), *trans*-3-hexene (5.3 mg, 0.06252 mmol, 6.1 %), and hexane (2.0 mg, 0.022971 mmol, 2.3%). Total yield of C<sub>6</sub> hydrocarbons was 45.4%.

**Trihexylgermane-d (51D).** A purged flask was charged with lithium aluminum deuteride (0.294 g, 7 mmol) and dry THF (125 mL) and cooled to -78 °C. Trihexylchlorogermane (**50**) (1.17 g, 3.22 mmol) was added slowly and the reaction mixture allowed to stir for 1 h before warming to room temperature and stirring for 2 h. The reaction mixture was quenched in water (75 mL) and extracted with hexane (2 x 50 mL). The combined organic portion was washed with water (50 mL), sat. sodium chloride (50 mL), and water (50 mL) then dried over magnesium sulfate. After solvent removal *in vacuo*, flash chromatography (hexane, silica gel) gave **51D** (0.6 g, 1.81 mmol, 56%) as a clear liquid. <sup>1</sup>H NMR (C<sub>6</sub>D<sub>6</sub>) δ 1.52 (m, 8H), 1.32 (m, 24H), 0.91, (m, 20H); <sup>13</sup>C NMR (C<sub>6</sub>D<sub>6</sub>) 33.7, 33.3, 27.1, 23.4, 14.7, 12.8; IR (neat, cm<sup>-1</sup>) 2957, 2956, 2923, 2852, 1447, 1377, 1169, 1101, 960, 695; GC-MS (EI): *m/z* 248 (14), 246 ([M-C<sub>6</sub>H<sub>13</sub>]<sup>+</sup>, 68), 245 (25), 244 (54), 243 (9), 242 (40), 164 (21), 163 (12), 162 (100), 161 (51), 160 (88), 159 (28), 159 (66), 157 (18), 156 (7), 134 (6), 133 (7), 132 (9), 131 (7), 130 (7), 129 (5), 120 (6), 119 (6), 118 (7), 117 (5), 116 (6), 115 (5), 106 (14), 105 (13), 104 (17), 103 (14), 102 (14), 101 (10), 89 (10), 87 (7), 85 (6), 84 (28), 83 (24), 74 (5), 57 (4), 56 (8), 55 (22).

**Flow pyrolysis of trihexylgermane-d (51D) over a germanium surface.** A solution of **51D** (0.112 g, 0.339 mmol), heptane (0.070 g), and toluene (3 mL) was added by syringe over 15 min through a 50 cm vertical quartz tube packed with quartz chips at 450 °C with a flow rate of 60 mL/min (He). The column surface had been coated with Ge/C by CVD. The pyrolysate was collected in a flask at -116 °C in an ethanol/N<sub>2</sub> bath. Conversion was 98.6% based on the remaining starting material. The following volatile products were observed (identified based on MS and comparison to known compounds, yields were determined by the internal standard method using appropriate R<sub>f</sub>s and are total yields based on 100% conversion): 1-hexene (21.6 mg, 0.2521 mmol, 57.9%), *trans*-2-hexene (8.6 mg, 0.102 mmol, 23%), *trans*-3-hexene (4.4 mg, 0.052758 mmol, 11.9 %), and hexane (2.2 mg, 0.025306 mmol, 5.6%). Total yield of C<sub>6</sub> hydrocarbons was 98.6%. Deuterium

incorporation was calculated to be 1-hexene (5%), *trans*-2-hexene (13%), *trans*-3-hexene (14%), hexane (14%) based on mass spectral analysis.

**Flow pyrolysis of trihexylgermane-d (51D) over a silica surface.** A solution of **51D** (0.062 g, 0.1873 mmol), *p*-xylene (0.043 g), and toluene (2 mL) was added by syringe over 15 min through a 50 cm vertical quartz tube packed with quartz chips at 475 °C with a flow rate of 60 mL/min (He). The pyrolysate was collected in a flask at -116 °C in an ethanol/N<sub>2</sub> bath. Conversion was 82.6% based on the remaining starting material. The following volatile products were observed (identified based on MS and comparison to known compounds, yields were determined by the internal standard method using appropriate R<sub>f</sub>s and are total yields based on 100% conversion): 1-hexene (10.33 mg, 0.12296 mmol, 21.9%), *trans*-2-hexene (18.81 mg, 0.224 mmol, 39.9%), *trans*-3-hexene (8.4 mg, 0.100 mmol, 17.9%), and hexane (1.33 mg, 0.015917 mmol, 2.8%). Total yield of C<sub>6</sub> hydrocarbons was 82.6%. Deuterium incorporation was calculated to be 1-hexene (9%), *trans*-2-hexene (17%), *trans*-3-hexene (15%), hexane (10%) based on mass spectral analysis.

**Tetrahexylgermane (42).** This compound was made according to the literature.<sup>68</sup> A flask was fitted with a mechanical stirrer and charged with hexylmagnesium bromide (420 mL, 840 mmol, 2 M in THF) and dry THF (200 mL), then cooled to -78 °C. A solution of germanium tetrachloride (22.8 g, 200 mmol) in dry THF (50 mL) was added dropwise by an addition funnel with stirring. The solution was allowed to warm to room temperature upon completion of addition, and stir for 3 h. The reaction mixture was then quenched in HCl (2 M, 200 mL) and extracted with pentane (3 x 150 mL). The combined organic portion was washed with sat. sodium bicarbonate (150 mL), water (150 mL), and sat. sodium chloride (150 mL) then dried over magnesium sulfate. After solvent removal *in vacuo*, the product was purified by flash chromatography (hexane, silica gel). This afforded **42** (74.5 g, 180 mmol, 90%) as a clear liquid (b.p. 158-161 °C/0.5 torr, lit. b.p. 192 °C/3 torr<sup>68</sup>). <sup>1</sup>H NMR (CDCl<sub>3</sub>) δ 1.28 (m, 32H), 0.89 (m, 12H), 0.68 (m, 8H); <sup>13</sup>C NMR (CDCl<sub>3</sub>) 33.5, 31.6, 25.3, 22.7, 14.2, 12.8; IR (neat, cm<sup>-1</sup>) 2956, 2920, 2851, 1459,

1169, 1100, 960, 692; GC-MS (EI):  $m/z$  331 (7), 330 (6), 329 ( $[M-C_6H_{13}]^+$ , 33), 328 (13), 327 (23), 325 (19), 247 (21), 246 (15), 245 (100), 243 (75), 241 (55), 163 (19), 162 (7), 161 (88), 160 (22), 159 (71), 158 (5), 157 (50), 133 (10), 131 (12), 129 (10), 119 (6), 117 (8), 115 (7), 105 (15), 103 (18), 101 (16), 89 (8), 87 (6), 83 (25), 55 (14).

**Flow pyrolysis of tetrahexylgermane (42) over a germanium surface.** A solution of tetrahexylgermane (42) (0.118 g 0.285 mmol) of, *p*-xylene (0.077 g), and toluene (3 mL) was added by syringe over 15 min through a 50 cm vertical quartz tube packed with quartz chips at 560 °C with a flow rate of 60 mL/min (He). The column surface had been coated with Ge/C by CVD. The pyrolysate was collected in a flask at -116 °C in an ethanol/N<sub>2</sub> bath. Conversion was 59.7% based on the remaining starting material. The following volatile products were observed (identified based on MS and comparison to known compounds, yields were determined by the internal standard method using appropriate R<sub>f</sub>s and are total yields based on 100% conversion): 1-hexene (14.3 mg, 0.170316 mmol, 14.9%), *trans*-2-hexene (14.3 mg, 0.16979 mmol, 14.9%), *trans*-3-hexene (7.7 mg, 0.092203 mmol, 8.1%), and hexane (4.4 mg, 0.050817 mmol, 4.5%). Total yield of C<sub>6</sub> hydrocarbons was 42.4%.

**Flow pyrolysis of tetrahexylgermane (42) over a silica surface.** A solution of tetrahexylgermane (42) (0.103 g 0.249 mmol) of, *p*-xylene (0.088 g), and toluene (3 mL) was added by syringe over 15 min through a 50 cm vertical quartz tube packed with quartz chips at 575 °C with a flow rate of 60 mL/min (He). The pyrolysate was collected in a flask at -116 °C in an ethanol / N<sub>2</sub> bath. Conversion was 50.6% based on the remaining starting material. The following volatile products were observed (identified based on MS and comparison to known compounds, yields were determined by the internal standard method using appropriate R<sub>f</sub>s and are total yields based on 100% conversion): 1-hexene (10.1 mg, 0.1199 mmol, 12%), *trans*-2-hexene (19.69 mg, 0.2345 mmol, 23.6%), *trans*-3-hexene (5.88 mg, 0.0700 mmol, 7.03%), and hexane (6.8 mg, 0.0794 mmol, 7.97%). Total yield of C<sub>6</sub> hydrocarbons was 50.6%.

**Methyltriphenylgermane (58).** This compound was made according to a modification of a literature procedure.<sup>69</sup> A 1 L flask was fitted with an addition funnel and mechanical stirrer, charged with dry ether (500 mL) and triphenylgermanium chloride (**53**) (34 g, 100 mmol), then cooled to  $-78\text{ }^{\circ}\text{C}$ . The addition funnel was charged with methylmagnesium bromide (38.3 mL, 115 mmol, 3 M in ether). The Grignard reagent was added slowly with stirring, upon completion of addition the reaction mixture was allowed to warm to room temperature and stir for 1.5 h. The reaction mixture was then quenched in HCl (2 M, 250 mL) and extracted with ether (2 x 150 mL). The combined organic fraction was washed with sat. sodium bicarbonate (150 mL), water (150 mL), and sat. sodium chloride (150 mL) then dried over magnesium sulfate. After solvent removal *in vacuo*, recrystallization from hexane gave **58** (29.6 g, 92.5 mmol, 92.5%) as a white crystalline material (m.p. 67-69  $^{\circ}\text{C}$ , lit. m.p. 66-67  $^{\circ}\text{C}$ <sup>70</sup>).  $^1\text{H}$  NMR ( $\text{CDCl}_3$ )  $\delta$  7.54 (m, 6H, ArH), 7.42 (m, 9h, ArH), 0.95 (s, 3H,  $\sim\text{GeCH}_3$ );  $^{13}\text{C}$  NMR ( $\text{CDCl}_3$ )  $\delta$  138.1, 134, 129, 128.3, -4.0; IR (neat film,  $\text{cm}^{-1}$ ) 3060, 3048, 3009, 3963, 2902, 1957, 1883, 1821, 1582, 1483, 1428, 1262, 1091, 1024, 787, 732, 697; GC-MS (EI):  $m/z$  320 ( $\text{M}^+$ , 1), 318 (1), 308 (4), 307 (21), 306 (20), 305 (100), 304 (39), 303 (76), 302 (5), 301 (58), 243 (15), 242 (5), 241 (11), 239 (9), 228 (4), 227 (15), 226 (10), 225 (12), 224 (5), 223 (8), 154 (10), 153 (10), 152 (8), 151 (27), 150 (9), 149 (21), 147 (16), 125 (4), 123 (4), 99 (5), 51 (12).

**Methyldiphenylbromogermane (59).** This compound was made according to a modification of the literature procedure.<sup>71</sup> A 500 mL flask fitted with addition funnel and stirbar was charged with bromoethane (250 mL) and methyltriphenylgermane (**58**) (16 g, 50 mmol). A solution of bromine (7.8 g, 2.55 mL, 48.6 mmol) in bromoethane (10 mL) was added slowly by addition funnel at room temperature with stirring. The reaction mixture was allowed to stir overnight. The solvent was removed by distillation under argon. Isolation by vacuum distillation provided **59** (16 g, 50 mmol, quant.) as a clear liquid (b.p. 156-157  $^{\circ}\text{C}$  / 1.5 torr).  $^1\text{H}$  NMR ( $\text{CDCl}_3$ )  $\delta$  7.72 (m, 4H, ArH), 7.5 (m, 6H, ArH), 1.35 (s, 3H,  $\sim\text{GeCH}_3$ );  $^{13}\text{C}$  NMR ( $\text{CDCl}_3$ )  $\delta$  136.6, 133.5, 128.9, 128.6, 2.9; IR (neat,  $\text{cm}^{-1}$ ) 3069, 3050, 2961, 2911, 1484, 1432, 1334, 1304, 1260, 1092, 1026, 998, 803, 734, 695, 603; GC-MS (EI):  $m/z$  324 ( $\text{M}^{+2}$ ,

5), 322 ( $M^+$ , 7), 320 (5), 311 (12), 309 (67), 308 (32), 307 (100), 305 (76), 303 (34), 245 (20), 344 (10), 243 (44), 241 (31), 239 (20), 230 (4), 229 (4), 228 (6), 227 (11), 226 (9), 225 (10), 224 (5), 223 (6), 157 (4), 155 (25), 154 (27), 153 (51), 152 (24), 151 (79), 150 (11), 149 (53), 147 (32), 125 (8), 124 (4), 123 (9), 121 (7), 91 (12), 90 (9), 87 (6), 85 (4), 77 (41), 75 (6), 74 (8), 65 (5), 51 (44), 50 (22); HRMS (EI)  $m/z$  calcd for  $C_{13}H_{13}GeBr$  320.94353, found 320.94426.

**Ethylmethyldiphenylgermane (60).** A solution of methyldiphenylbromogermane (**59**) (16 g, 50 mmol) in dry THF (150 mL) was cooled to  $-78\text{ }^\circ\text{C}$  in a 250 mL flask fitted with addition funnel and stirbar. Next, ethylmagnesium chloride (37.5 mL, 75 mmol, 1.93 M in THF) was added slowly by an addition funnel with stirring. Upon completion of addition the reaction mixture was warmed to room temperature and stirred for 1.5 h. The reaction mixture was quenched in HCl (2 M, 200 mL) and extracted with ether (2 x 150 mL). The combined organic fraction was washed with sat. sodium bicarbonate (150 mL), water (150 mL), sat. sodium chloride (150 mL) then dried over magnesium sulfate. Solvent removal *in vacuo* gave **60** (13.5 g, 49.6 mmol, quant.) as a clear liquid. No further purification was required.  $^1\text{H}$  NMR ( $\text{CDCl}_3$ )  $\delta$  7.52 (m, 4H, ArH), 7.38 (m, 6H, ArH), 1.3 (t(br),  $J = 6.0$  Hz, 2H,  $\sim\text{GeCH}_2\text{CH}_3$ ), 1.15 (d(br),  $J = 6.0$  Hz, 3H,  $\sim\text{GeCH}_2\text{CH}_3$ ), 0.66 (s, 3H,  $\sim\text{GeCH}_3$ );  $^{13}\text{C}$  NMR ( $\text{CDCl}_3$ )  $\delta$  139.4, 134.1, 128.6, 128.2, 8.9, 7.0, -5.7; IR (neat,  $\text{cm}^{-1}$ ) 3050, 2905, 2870, 1484, 1429, 1237, 1091, 1017, 786, 733, 690; GC-MS (EI):  $m/z$  257 (3), 254 (2), 245 (21), 244 (17), 243 ( $[\text{M}-\text{C}_2\text{H}_5]^+$ , 100), 242 (39), 241 (78), 239 (58), 229 (11), 228 (7), 227 (20), 226 (9), 225 (16), 224 (5), 223 (8), 165 (4), 154 (7), 153 (8), 152 (6), 151 (27), 150 (11), 149 (22), 147 (16), 125 (4), 123 (4), 99 (5), 97 (4), 91 (4), 90 (5), 87 (4), 77 (5), 51 (8), 50 (4); HRMS (EI)  $m/z$  calcd for  $C_{15}H_{18}Ge$  268.0651, found 268.06589.

**Ethylmethylphenylbromogermane (61).** A 250 mL flask was fitted with an addition funnel and stirbar was charged with a solution of ethylmethyldiphenylgermane (**60**) (13.6 g, 50 mmol) and bromoethane (200 mL). A solution of (8 g, 2.58 mL, 50 mmol) of bromine in bromoethane (10 mL) was added slowly by an addition funnel at  $0\text{ }^\circ\text{C}$ . Upon completion the reaction mixture was warmed to room

temperature and stirred overnight. The product was isolated by vacuum distillation after solvent removal by distillation under argon. This provided **61** (10 g, 36.5 mmol, 73%) as a clear liquid (b.p. 76-77 °C/2.5 torr).  $^1\text{H}$  NMR ( $\text{CDCl}_3$ )  $\delta$  7.60 (m, 2H, ArH), 7.44 (m, 3H, ArH), 1.49 (m, 2H,  $\sim\text{GeCH}_2\text{CH}_3$ ), 1.2 (t,  $J = 7.8$  Hz, 3H,  $\sim\text{GeCH}_2\text{CH}_3$ ), 1.03 (s, 3H,  $\text{GeCH}_3$ );  $^{13}\text{C}$  NMR ( $\text{CDCl}_3$ )  $\delta$  137.6, 132.9, 130.2, 128.6, 13.5, 8.5, 1.6; IR (neat,  $\text{cm}^{-1}$ ) 3070, 2960, 2908, 2873, 1484, 1457, 1431, 1241, 1092, 1022, 964, 800, 734, 696, 608; GC-MS (EI):  $m/z$  276 ( $\text{M}^{+2}$ , 3), 274 ( $\text{M}^+$ , 5), 272 (4), 270 (2), 261 (4), 259 (6), 257(5), 249 (12), 247 (67), 246 (24), 245 (100), 243 (76), 241 (34), 233 (5), 232 (4), 231 (9), 230 (6), 229 (7), 195 (4), 169 (4), 167 (7), 165 (6), 163 (4), 155 (13), 153 (24), 152 (6), 151 (39), 150 (10), 149 (26), 147 (15), 125 (23), 123 (4), 121 (3), 99 (6), 97 (5), 95 (3), 91 (6), 89 (9), 87 (7), 85 (5), 77 (9), 74 (4), 51 (12), 50 (6); HRMS (EI)  $m/z$  calcd for  $\text{C}_9\text{H}_{13}\text{GeBr}$  272.94353, found 272.94393.

**Ethylmethylphenyl(trimethylsilyl)germane (62).** A 100 mL flask was charged with lithium wire (1 g, 146 mmol) and dry THF (40 mL). Next, ethylmethylphenylbromogermane (**61**) (8 g, 29.2 mmol) was added to the mixture with stirring at room temperature under argon. The solution turned red-black after 20 min and was then allowed to stir for 4 h at which time the solution was transferred by canula to a 250 mL flask containing a stirring solution of trimethylsilyl chloride (12.6 g, 14.7 mL, 116.8 mmol) in THF (100 mL) cooled to  $-78$  °C. The reaction mixture was stirred for 1 h then warmed to room temperature. Next, the reaction mixture was quenched in HCl (1 M, 150 mL) and extracted with ether (2 x 100 mL). The combined organic fraction was then washed with sat. sodium bicarbonate (100 mL), water (100 mL), sat. sodium chloride (100 mL) then dried over magnesium sulfate. After solvent removal *in vacuo*, vacuum distillation afforded **62** (3.1 g, 11.6 mmol, 40%) as a clear liquid (b.p. 64-65 °C/2.5 torr). The main byproduct was 1,2-diethyl-1,2-dimethyl-1,2-diphenyl-digermane (2.5 g, 6.4 mmol, 44%), which was isolated by vacuum distillation as a clear liquid (b.p. 133-135 °C/2.5 torr). **62**:  $^1\text{H}$  NMR ( $\text{CDCl}_3$ )  $\delta$  7.42 (m, 2H, ArH), 7.32 (m, 3H, ArH), 1.09 (m, 5H,  $\sim\text{GeC}_2\text{CH}_5$ ), 0.4 (s, 3H,  $\sim\text{GeCH}_3$ ), 0.12 (s, 9H,  $\sim\text{Si}(\text{CH}_3)_3$ );  $^{13}\text{C}$  NMR ( $\text{CDCl}_3$ )  $\delta$  141.5, 134.0, 127.9, 127.7, 10.0, 6.7, -0.9, -7.3; IR (neat,  $\text{cm}^{-1}$ ) 3070, 2952, 2924, 2853, 1258, 1247, 835; GC-MS (EI):  $m/z$

268 ( $M^+$ , 5), 267 (2), 266 (4), 264 (3), 241 (9), 240 (7), 239 (40), 238 (15), 237 (30), 235 (22), 225 (5), 223 (4), 221 (3), 167 (9), 165 (7), 163 (5), 151 (14), 150 (5), 149 (12), 147 (18), 137 (5), 136 (15), 135 (100), 121 (6), 91 (4), 89 (9), 87 (7), 85 (5), 74 (4), 73 (33), 59 (4); HRMS (EI)  $m/z$  calcd for  $C_{12}H_{22}GeSi$  268.07016, found 268.07059.

**Ethylmethyl(trimethylsilyl)germanium bromide (63).** A 100 mL flask fitted with addition funnel and stirbar and containing a solution of ethylmethylphenyl-(trimethylsilyl)germane (**62**) (3.0 g, 11.2 mmol) in bromoethane (75 mL) was cooled to  $-78$  °C under argon. A solution of bromine (1.76 g, 0.57 mL, 11 mmol) in bromoethane (11 mL) was added dropwise by an addition funnel with stirring. Upon completion of addition the reaction mixture was stirred for an additional 5 h at  $-78$  °C, then allowed to warm to room temperature and stir overnight. Solvent removal was accomplished by distillation under argon. The product was isolated by means of vacuum distillation, affording **63** (2.25 g, 8.33 mmol, 74%) as a clear liquid (b.p. 98-101 °C/12 torr).  $^1H$  NMR ( $CDCl_3$ )  $\delta$  1.27-1.15 (m, 5H,  $\sim GeC_2H_5$ ), 0.77 (s, 3H,  $\sim GeCH_3$ ), 0.29 (s, 9H,  $\sim Si(CH_3)_3$ );  $^{13}C$  NMR ( $CDCl_3$ )  $\delta$  13.4, 9.3, 0.9, -0.5; IR (neat,  $cm^{-1}$ ) 2955, 2924, 2872, 1469, 1398, 1248, 1071, 1020, 842, 744, 697; GC-MS (EI):  $m/z$  272 ( $M^{+2}$ , 3), 270 ( $M^+$ , 4), 268 (3), 243 (3), 241(4), 239 (4), 155 (4), 153 (5), 151 (4), 120 (4), 118 (21), 117 (7), 116 (16), 114 (12), 89 (7), 87 (9), 85 (4), 75 (4), 74 (10), 75 (100), 59 (7); HRMS (EI)  $m/z$  calcd for  $C_6H_{17}GeBr$  269.94892, found 269.94953.

**Ethylmethyl(trimethylsilyl)germane (64).** A 100 mL flask with stirbar was charged with a solution of ethylmethyl(trimethylsilyl)germanium bromide (**63**) (2.2 g, 8.1 mmol) in dry ether (50 mL), and was cooled to  $-78$  °C under argon. Next, lithium aluminum hydride (8 mL, 8 mmol, 1.0 M in ether) was added slowly by an addition funnel with stirring. The reaction mixture was stirred for 0.5 h, then warmed to room temperature and stirred for an additional hour. The reaction mixture was quenched in cold water (100 mL) and extracted with pentane (2 x 75 mL). The combined organic fraction was washed with water (75 mL), sat. sodium chloride (75 mL), and water (50 mL) then dried over magnesium sulfate. Solvent removal *in vacuo* followed

by vacuum distillation gave **64** (1.33 g, 6.9 mmol, 85%) as a clear liquid (b.p. 52-54 °C/12 torr).  $^1\text{H}$  NMR ( $\text{C}_6\text{D}_6$ )  $\delta$  3.59 (sextet,  $J = 3.9$  Hz, 1H,  $\sim\text{GeH}$ ), 1.10 (td,  $J = 7.8, 0.9$  Hz, 3H,  $\sim\text{GeCH}_2\text{CH}_3$ ), 0.86 (m, 2H,  $\sim\text{GeCH}_2\text{CH}_3$ ), 0.21 (d,  $J = 3.3$  Hz, 3H,  $\sim\text{GeCH}_3$ ), 0.10 (s, 9H,  $\text{Si}(\text{CH}_3)_3$ );  $^{13}\text{C}$  NMR ( $\text{C}_6\text{D}_6$ )  $\delta$  11.5, 4.4, -1.0, -9.9; IR (neat,  $\text{cm}^{-1}$ ) 2950, 2905, 2869, 2825, 1988, 1458, 1390, 1246, 1019, 963, 836, 788, 751, 692, 619; GC-MS (EI):  $m/z$  194 (2), 192 ( $\text{M}^+$ , 9), 191 (9), 190 (7), 188 (5), 177 (4), 175 (3), 173 (2), 163 (7), 162 (4), 161 (6), 159 (4), 149 (7), 147 (7), 145 (5), 120 (8), 119 (3), 118 (36), 117 (12), 116 (28), 115 (5), 114 (22), 103 (6), 101 (5), 99 (4), 91 (9), 90 (4), 89 (29), 88 (10), 87 (25), 86 (3), 85 (15), 75 (5), 74 (11), 73 (100), 59 (14); HRMS (EI)  $m/z$  calcd for  $\text{C}_6\text{H}_{18}\text{GeSi}$  192.042673, found 192.042804.

**Flow pyrolysis of ethylmethyl(trimethylsilyl)germane (64).** A solution of **64** (0.100 g, 0.521 mmol) and heptane (0.06 g) as an internal standard in 2,3-dimethyl-1,3-butadiene (9 mL) was subjected to flow pyrolysis at 325 °C in a 50 cm vertical quartz tube with 60 mL/min He flow. The pyrolysate was collected in a trap cooled to -78 °C. The product yields were first determined by GC-MS using the internal standard method. The following products were observed: 1,3,4-trimethyl-1-germacyclopent-3-ene **67** (0.025 g, 0.125 mmol, 24%), 1-ethyl-1,3,4-trimethyl-1-germacyclopent-3-ene **66** (0.021 g, 0.122 mmol, 23.4%), and the double addition product **68** (0.053 g, 0.21 mmol, 40.3%). The products were isolated by preparative GC (8 ft  $\frac{1}{4}$  inch column packed with 14% SE-30 on chromosorb-W-HP, oven temperature: 150 °C (isothermal), injector port temperature: 180 °C, detector temperature of 190 °C, and flow of 55 mL/min He). This gave **67** (0.004 g, 0.021 mmol, 4%), **66** (0.005 g, 0.025 mmol, 4.8%) and **68** (0.021 g, 0.083 mmol, 16%).

**67.**  $^1\text{H}$  NMR ( $\text{C}_6\text{D}_6$ )  $\delta$  4.26 (sextet,  $J = 3.0$  Hz, 1H,  $\sim\text{GeH}$ ), 1.74 (dd,  $J = 6.8, 1.2$  Hz, 2H,  $\sim\text{CH}_2(\text{CH}_3)\text{C}=\text{C}\sim$ ), 1.64 (s, 6H,  $\sim\text{CH}_2(\text{CH}_3)\text{C}=\text{C}\sim$ ), 1.4 (dd,  $J = 18, 1.5$  Hz, 2H,  $\sim\text{CH}_2(\text{CH}_3)\text{C}=\text{C}\sim$ ), 0.24 (d,  $J = 3.3$  Hz, 3H,  $\sim\text{GeCH}_3$ );  $^{13}\text{C}$  NMR ( $\text{C}_6\text{D}_6$ )  $\delta$  131.3, 24.8, 19.8, -4.7; IR (neat,  $\text{cm}^{-1}$ ) 2980, 2911, 2886, 2855, 2034, 1447, 1374, 1275, 1238, 1169, 1114, 1058; GC-MS (EI):  $m/z$  174 (9), 173 (4), 172 ( $\text{M}^+$ , 41), 171 (16), 170 (32), 169 (6), 162 (22), 159 (21), 158 (8), 157 (100), 156 (29), 155 (77), 154 (8), 153 (59), 130 (4), 129 (12), 128 (7), 127 (10), 126 (4), 125 (8), 117 (15), 116 (4), 115



(69), 114 (20), 113 (58), 112 (8), 111 (43), 109 (4), 101 (12), 100 (4), 99 (12), 97 (9), 91 (17), 90 (6), 89 (71), 88 (24), 87 (54), 86 (7), 85 (39), 93 (8), 81 (4), 75 (11), 73 (6), 72 (7), 67 (15), 65 (4), 55 (22), 53 (7); HRMS (EI)  $m/z$  calcd for  $C_7H_{14}Ge$  171.03301, found 171.03335.

**66.**  $^1H$  NMR ( $CDCl_3$ )  $\delta$  1.72 (s, 6H,  $\sim CH_2(CH_3)C=C\sim$ ), 1.6-1.4 (m, 4H,  $\sim CH_2(CH_3)C=C\sim$ ), 1.04 (t,  $J = 7.5$  Hz, 3H,  $\sim GeCH_2CH_3$ ), 0.83 (q,  $J = 8.1$  Hz, 2H,  $\sim GeCH_2CH_3$ ), 0.24 (s, 3H,  $\sim GeCH_3$ );  $^{13}C$  NMR ( $CDCl_3$ )  $\delta$  131.2, 25.1, 19.7, 9.3, 7.6, -4.4; IR (neat,  $cm^{-1}$ ); GC-MS (EI):  $m/z$  202 (8), 201 (4), 200 ( $M^+$ , 38), 199 (12), 198 (29), 196 (21), 185 (8), 183 (6), 181 (5), 173 (21), 172 (9), 171 (100), 170 (30), 169 (77), 167 (58), 157 (11), 155 (10), 153 (10), 143 (8), 141 (7), 139 (6), 129 (14), 128 (5), 127 (12), 125 (9), 120 (8), 118 (36), 117 (13), 116 (28), 115 (14), 114 (24), 113 (74), 112 (4), 111 (10), 105 (4), 103 (16), 102 (4), 101 (18), 99 (16), 91 (23), 90 (10), 89 (90), 88 (30), 87 (68), 86 (11), 85 (48), 75 (8), 74 (7), 73 (7), 72 (4), 71 (4), 67 (9), 53 (5); HRMS (EI)  $m/z$  calcd for  $C_9H_{18}Ge$  199.06431, found 199.06469.

**1,3,4-Trimethylgermacylopent-3-ene (67).** A 250 mL flask fitted with addition funnel and stirbar was charged with ether (200 mL) and 1,1-dichloro-3,4-dimethylgermacylopent-3-ene **69** (2.052 g, 9.04 mmol), then cooled to  $-78$  °C. Next, methylmagnesium bromide (1.5 mL, 4.5 mmol, 3 M in ether) was added dropwise by an addition funnel with stirring. Upon completion, the reaction mixture allowed to stir for 1 h, then warm to room temperature. The solvent was then removed *in vacuo*. Pentane was added to the crude product and the magnesium salts were filtered out under argon. Again the solvent was removed *in vacuo* and the crude reaction mixture distilled, giving 1.31 g of material. This mixture syringed into a 100 mL flask charged with ether (50 mL) and cooled to  $-78$  °C. The mixture was reduced by the addition of excess lithium aluminum hydride. After the reaction was complete, the mixture was warmed to room temperature. The reaction mixture was quenched in cold water (100 mL) and extracted with pentane (2 x 75 mL). The combined organic fraction was washed with water (75 mL), sat. sodium chloride (75 mL), and water (50 mL) then dried over magnesium sulfate. GC analysis of the product mixture showed the following products: 1,1,3,4-tetramethylgermacylopent-3-ene **38** (14%),

1,3,4-trimethylgermacyclopent-3-ene **67** (17%), and 3,4-dimethylgermacyclopenta-3-ene **71** (39%). Solvent removal *in vacuo*, followed by preparative GC (8 ft ¼ inch column packed with 14% SE-30 on chromosorb-W-HP, oven temperature: 90 °C (isothermal), injector port temperature: 90 °C, detector temperature of 120 °C, and flow of 28 mL/min He) provided **67** (0.060 g, 0.349 mmol, 4% yield).

**1-Ethyl-1,3,4-trimethylgermacyclopent-3-ene (66).** A 250 mL flask fitted with addition funnel and stirbar was charged with THF (200 mL) and 1,1-dichloro-3,4-dimethylgermacyclopent-3-ene **69** (2.142 g, 9.44 mmol), then cooled to -78 °C. Next, methylmagnesium bromide (1.57 mL, 4.72 mmol, 3 M in ether) was added dropwise by an addition funnel with stirring. Upon completion, the reaction mixture allowed to stir for 1 h, then warm to room temperature and stir for 30 min. The reaction mixture was again cooled to -78 °C. Excess ethylmagnesium bromide (13 mL, 26 mmol, 2 M in THF) was added by an addition funnel. After addition, the reaction mixture allowed to stir for 1 h, then warm to room temperature and stir for 30 min. The reaction mixture was quenched in cold water (100 mL) and extracted with pentane (2 x 75 mL). The combined organic fraction was washed with water (75 mL), sat. sodium chloride (75 mL), and water (50 mL) then dried over magnesium sulfate. The crude product mixture was distilled, giving 1.3 g of material. GC analysis of the product mixture showed the following products 1,1,3,4-tetramethylgermacyclopent-3-ene **38** (8%), 1-ethyl-3,4-trimethylgermacyclopent-3-ene **67** (27%), 1,1-diethyl-3,4-dimethylgermacyclopent-3-ene **72** (34%). Solvent removal *in vacuo*, followed by preparative GC (8 ft ¼ inch column packed with 14% SE-30 on chromosorb-W-HP, oven temperature: 90 °C (isothermal), injector port temperature: 90 °C, detector temperature of 120 °C, and flow of 28 mL/min He) provided **66** (0.087 g, 0.435 mmol, 4.6% yield).

**3-Methyl-1-germacyclopent-3-ene (54).** A modification of the procedure of Takeuchi was used in the synthesis of **71**.<sup>48</sup> A 100 mL flask equipped with a J. Young valve was charged with germanium diiodide (4.943 g, 15.12 mmol) and hexane (10 mL). Next the reaction was charged with isoprene (0.68 g, 2.05 mL, 20.5 mmol) and the vessel sealed. The reaction mixture was stirred at room

temperature for 6 h, then heated to 50 °C for 3 h. The resulting 1,1-diiodo-1-germacyclopent-3-ene was transferred by canula to a flask containing a mixture of lithium hydride (0.44 g, 55.5 mmol) in ether (30 mL) cooled to 0 °C. The reaction mixture was allowed to stir for 15 min, then warm to room temperature and stir for 2 h. The reaction mixture was then refluxed for 24 h to drive the reduction to completion. The reaction mixture was quenched in chilled HCl (1 M, 100 mL), then extracted with pentane (2 x 75 mL). The combined organic layer was washed with sat. sodium bicarbonate (75 mL), water (75 mL) and sat. sodium chloride (75 mL) then dried over magnesium sulfate. Solvent removal *in vacuo* followed by distillation provided **54** (1.9 g, 7.9 mmol, 79%) as a clear liquid (b.p. 117 °C/760 torr). <sup>1</sup>H NMR (CDCl<sub>3</sub>) δ 5.94 (t, *J* = 0.8 Hz, 2H, ~CH<sub>2</sub>(H)C=C~), 3.95 (m, 2H, ~GeH<sub>2</sub>), 1.43 (d, *J* = 0.8 Hz, 4H, ~CH<sub>2</sub>(H)C=C); <sup>13</sup>C NMR (CDCl<sub>3</sub>) δ 131.7, 27.7; GC-MS (EI): *m/z* 146 (6), 145 (11), 144 (M<sup>+</sup>, 76), 153 (49), 142 (78), 141 (32), 140 (52), 139 (25), 138 (8), 137 (5), 131 (14), 130 (3), 129 (68), 128 (18), 127 (59), 126 (6), 125 (46), 124 (2), 123 (7), 118 (20), 117 (12), 116 (100), 115 (64), 114 (93), 113 (47), 112 (72), 111 (35), 110 (10), 109 (9), 104 (7), 103 (17), 102 (36), 101 (72), 100 (45), 99 (65), 98 (28), 97 (47), 96 (4), 95 (11), 91 (15), 90 (6), 89 (69), 88 (35), 87 (56), 86 (16), 85 (40), 84 (10), 77 (7), 76 (13), 75 (24), 74 (50), 73 (28), 72 (34), 71 (14), 70 (26), 69 (41), 68 (15), 67 (47), 66 (4), 65 (7), 55 (4), 54 (2), 53 (33), 52 (3), 51 (8).

**3,4-Dimethyl-1-germacyclopent-3-ene (71).** A modification of the procedure of Takeuchi was used in the synthesis of **71**.<sup>48</sup> A 100 mL flask equipped with a J. Young valve was charged with germanium diiodide (15.04 g, 46.1 mmol) and hexane (15 mL). Next the reaction was charged with 2,3-dimethyl-1,3-butadiene (4.6 g, 6 mL, 53 mmol) and the vessel sealed. The reaction mixture was stirred at room temperature for 6 h, then heated to 50 °C for 3 h. The resulting 1,1-diiodo-1-germacyclopent-3-ene was transferred by canula to a flask containing lithium aluminum hydride (15 mL, 15 mmol, 1 M in ether) cooled to -78 °C. The reaction mixture was allowed to stir for 30 min, then warm to room temperature and stir for 2 h. The reaction mixture was quenched in chilled HCl (1 M, 150 mL), then extracted with pentane (2 x 100 mL). The combined organic layer was washed with

sat. sodium bicarbonate (100 mL), water (100 mL) and sat. sodium chloride (100 mL) then dried over magnesium sulfate. Solvent removal *in vacuo* followed by distillation provided **71** (1.9 g, 7.9 mmol, 79%) as a clear liquid (b.p. 142 °C/760 torr).  $^1\text{H}$  NMR ( $\text{CDCl}_3$ )  $\delta$  5.94 (t,  $J = 0.8$  Hz, 2H,  $\sim\text{CH}_2(\text{H})\text{C}=\text{C}\sim$ ), 3.93 (quintet,  $J = 3.0$  Hz, 2H,  $\sim\text{GeH}_2$ ), 1.43 (d,  $J = 0.8$  Hz, 4H,  $\sim\text{CH}_2(\text{H})\text{C}=\text{C}$ );  $^{13}\text{C}$  NMR ( $\text{CDCl}_3$ )  $\delta$  131.7, 27.7; GC-MS (EI):  $m/z$  160 (13), 159 (8), 158 ( $\text{M}^+$ , 65), 157 (34), 156 (58), 155 (19), 154 (40), 153 (13), 152 (5), 145 (7), 143 (36), 142 (9), 141 (129), 139 (26), 137 (5), 130 (4), 129 (8), 128 (7), 127 (8), 126 (5), 125 (6), 118 (22), 117 (15), 116 (100), 115 (83), 114 (91), 113 (58), 112 (64), 111 (42), 110 (7), 109 (9), 103 (6), 102 (8), 101 (27), 100 (13), 99 (27), 98 (9), 97 (20), 95 (5), 91 (15), 90 (4), 89 (60), 88 (23), 87 (48), 86 (8), 85 (34), 84 (7), 83 (27), 82 (6), 81 (9), 79 (6), 77 (7), 76 (9), 75 (15), 74 (33), 73 (18), 72 (21), 71 (18), 70 (20), 69 (5), 67 (8), 65 (7), 56 (5), 55 (95), 54 (11), 53 (14), 51 (7).

**Flow pyrolysis of 3-methyl-1-germacyclopent-3-ene (54) in the presence of isoprene over a germanium surface.** A solution of **54** (0.21 g, 1.52 mmol) in isoprene (5 mL) was added by syringe over 15 min through a 50 cm vertical quartz tube packed with quartz chips at 350 °C with a flow rate of 60 mL/min (He). The column surface had been coated with Ge/C by CVD. The pyrolysate was collected in a flask at  $-78$  °C in an dry ice/2-propanol bath. Conversion estimated at 30 % based on the remaining starting material. One germanium-containing product was produced in trace amount. The GC-MS spectra of the product corresponds to the formal addition, perhaps through hydrogermylation, of isoprene to **54**. The most likely structure is 1-(2-methyl-2-butenyl)-3-methyl-1-germacyclopent-3-ene **55**. GC-MS (EI):  $m/z$  212 ( $\text{M}^+$ , 19), 211 (11), 210 (16), 208 (14), 144 (51), 143 (16), 142 (68), 141 (16), 140 (49), 139 (8), 138 (31), 118 (22), 117 (5), 116 (100), 115 (30), 114 (76), 113 (14), 112 (62), 102 (8), 101 (9), 100 (110), 99 (14), 98 (8), 97 (14), 89 (14), 88 (5), 87 (14), 85 (5), 75 (5), 74 (14), 73 (6), 72 (8), 71 (4), 70 (5), 69 (7), 67 (8), 53 (8).

**Flow pyrolysis of 3,4-dimethyl-1-germacyclopent-3-ene (71) in the presence of 2,3-dimethyl-1,3-butadiene over a germanium surface.** A solution

of **71** (0.5 g, 3.16 mmol) in 2,3-dimethyl-1,3-butadiene (10 mL) was added by syringe over 15 min through a 50 cm vertical quartz tube packed with quartz chips at 375 °C with a flow rate of 60 mL/min (He). The column surface had been coated with Ge/C by CVD. The pyrolysate was collected in a flask at -78 °C in an dry ice/2-propanol bath. Conversion estimated at 70 % based on the remaining starting material. Two germanium-containing products were produced in a 2:1 ratio. The GC-MS spectra of the product corresponds to the formal addition, perhaps through hydrogermylation, of 2,3-dimethyl-1,3-butadiene to **71**. The most likely structures are 1-(2,3-dimethyl-2-butenyl)-3,4-dimethyl-1-germacyclopent-3-ene and the isomer 1-(2,3-dimethyl-3-butenyl)-3,4-dimethyl-1-germacyclopent-3-ene. GC-MS (EI): *m/z* 242 (6), 241 (4), 240 (M<sup>+</sup>, 31), 239 (10), 238 (23), 236 (17), 158 (24), 157 (10), 156 (100), 155 (31), 154 (76), 153 (10), 152 (56), 118 (12), 117 (4), 116 (56), 115 (22), 114 (47), 113 (11), 112 (35), 111 (7), 89 (9), 88 (4), 87 (8), 85 (6).

### References

- (1) Brown, R. D. *US Geological Survey Minerals Yearbook-2000* 2000, 33.1.
- (2) Vogelen, E. Z. Z. *ANorg. Allg. Chem* 1902, 30, 324.
- (3) Tamaru, K.; Boudart, M.; Taylor, H. *J. Phys. Chem.* 1955, 59, 806.
- (4) Fensham, P. J.; Tamaru, K.; Boudart, M. *J. Phys. Chem.* 1955, 59, 806.
- (5) Tamaru, K. *Bull. Chem. Soc. Jpn.* 1958, 31, 647.
- (6) Devyatykh, G. G.; Frolov, I. A. *Zh. Neorg. Khim.* 1966, 12, 708.
- (7) Devyatykh, G. G.; Zorin, A. D. *Volatile Inorganic Superpure Hydrides*; Nauka: Moscow, 1974.
- (8) Hall, L. H. *J. Electrochem. Soc.* 1972, 119, 1593.
- (9) Newman, C. G.; Ring, M. A.; O'Neal, H. E. *Int. J. Chem. Kinet.* 1979, 11, 1167.
- (10) Hogness, T. R.; Johnson, W. C. *J. Am. Chem. Soc.* 1932, 54, 3583.
- (11) Azatyan, V. V.; Aivazyan, R. G.; Pavlov, N. M.; Sinel'nikova, T. A. *Kinetics and Catalysis* 1993, 34, 518.

- (12) Votintsev, V. N.; Zaslanko, I. S.; Mikheev, V. S.; Smirnov, V. N. *Kinetika Kataliz* **1985**, 26, 1114.
- (13) Newman, C. G.; Dzarnoski, J.; Ring, M. A.; O'Neal, H. E. *Int. J. Chem. Kin.* **1980**, 12, 661.
- (14) Green, M. C.; ALis, J. S.; Brasen, D.; Nakahara, S. *J. Electron. Mater.* **1988**, 17, 229.
- (15) Kohanek, J. J.; Estecio, P.; Ring, M. A. *Inorg. Chem.* **1969**, 8, 2516.
- (16) Dzarnoski, J.; O'Neal, H. E.; Ring, M. A. *J. Am. Chem. Soc.* **1981**, 103, 5740.
- (17) Paquin, D. P.; O'Connor, R. J.; Ring, M. A. *J. Organomet. Chem.* **1974**, 80, 341.
- (18) Salimgareeva, I. M.; Bogatova, N. G.; Panasenko, A. A.; Khalilov, L. M.; Furlei, I. I.; Mavrodiev, V. K.; Yur' ev, V. P. *Bul. Adad. Sci. USSR, Chem. Sci* **1983**, 7, 1456.
- (19) Satge, J.; Massol, M.; Lesbre, M. *J. Organometal. Chem.* **1966**, 5, 241.
- (20) Satge, J.; Massol, M. *Compt. Rend.* **1965**, 261, 170.
- (21) Dzurinskaya, N. G.; Mironov, V. F.; Petrov, A. D. *Dokl. Akad. Nauk SSSR* **1961**, 138, 1107.
- (22) Davidson, I. M. T.; Lambert, C. A. *J. Chem. Soc. A.* **1971**, 882.
- (23) Harrison, P. G.; McManus, J.; Podesta, D. M. *J. Chem. Soc. Chem. Commun.* **1992**, 291.
- (24) Taylor, J. E.; Milazzo, T. S. *J. Phys. Chem* **1978**, 82, 847.
- (25) Yablokov, V. A.; Dozorov, A. V.; Feshcjenko, I. A.; Zorin, A. B. *Zh. Obsch. Khim.* **1983**, 53, 106.
- (26) Jackson, R. A. *J. Organometal. Chem.* **1979**, 166, 17.
- (27) Dzarnoski, J.; Ring, M. A.; O'Neal, H. E. *Int. J. Chem. Kinet.* **1981**, 14, 279.
- (28) Smith, G. P.; Patrick, R. *Int. J. Chem. Kinet.* **1983**, 15, 167.
- (29) Stanley, A. E.; Johnson, R. A.; Turner, J. B.; Roberts, A. H. *Appl. Spectrosc.* **1986**, 40, 374.
- (30) Stanley, A. E. ; US Dept. of the Army: USA, 1986, pp 36.
- (31) Mazerolles, P. *Silicon, Germanium, Tin and Lead Compounds* **1986**, 9, 155.

- (32) Harrison, D. G.; Torr, A. C. *Organometallics* **1995**, *14*, 3307.
- (33) Almond, M. J.; Doncaster, A. M.; Noble, P.; Walsh, R. *J. Am. Chem. Soc.* **1982**, *104*, 4717.
- (34) Louchs, L. F.; Laidler, K. J. *Can. J. Chem.* **1967**, *45*, 2795.
- (35) Trenwith, A. B. *J. Chem. Soc., Faraday Trans. 2* **1986**, *82*, 457.
- (36) Geddes, R. L.; Mack, E. J. *J. Am. Chem. Soc.* **1930**, *52*, 4372.
- (37) Hurd; Spence *J. Am. Chem. Soc.* **1929**, *51*, 3353.
- (38) Sladkova, T. A.; Berezhanskaya, O. P.; Zolotarev, B., M.; Razuvuaev, G. A. *Izv. Akad. Nauk. SSSR, Ser. Khim.* **1978**, *6*, 1141.
- (39) Bouchman, J.; Amjoud, M.; Morancho, R.; Maury, F.; Yacoubi, A. *Ann. Chim. Sci. Mat.* **1998**, *23*, 381.
- (40) Lei, D.; Gaspar, P. P. *Polyhedron* **1991**, *10*, 1221.
- (41) Nuemann, W. P. *Chem. Rev.* **1991**, *91*, 311.
- (42) Riviere, P.; Castel, A.; Satge, J.; Guyot, D. *J. Organomet. Chem.* **1986**, *315*, 157.
- (43) Bulten, E. J.; Noltes, J. G. *J. Organomet. Chem.* **1969**, *16*, P8.
- (44) Tillman, N. *Gas phase thermal interconversions of silacyclobutanes, alkylsilanes and silacyclopropanes*; Iowa State University: Ames, 1986.
- (45) Lei, D.; Lee, M. E.; Gaspar, P. P. *Tetrahedron* **1997**, *53*, 10179.
- (46) Lange, L.; Meyer, B.; du Pont, W. *J. Organometal. Chem.* **1987**, *329*, C21.
- (47) Grev, R. S.; Schaefer, H. F., III *Organometallics* **1992**, *11*, 3489.
- (48) Takeuchi, Y.; Tanaka, K.; Harazono, T. *Bull. Chem. Soc. Jpn.* **1991**, *64*, 91.
- (49) Mironov, V. F.; Kravchenko, A. L. *Izv. Akad. Nauk. SSSR* **1965**, 1026.
- (50) Bulten, E. J.; Drenth, W. *J. Organometal. Chem.* **1973**, *61*, 179.
- (51) Ando, W.; Ohgaki, H.; Kabe, Y. *Angew. Chem. Int. Ed.* **1994**, *33*, 659.
- (52) Ohgaki, H.; Kabe, Y.; Ando, W. *Organometallics* **1995**, *14*, 2139.
- (53) Becerra, R.; Walsh, R. *J. Organometallic Chem.* **2001**, 636, 49.
- (54) Su, M.-D.; Chu, S.-Y. *J. Phys. Chem. A* **1999**, *103*, 11011.
- (55) Biemann, K. *Mass Spectrometry, Organic Chemical Applications*; McGraw Hill: New York, 1982.

- (56) Takahashi, Y.; Ishii, H.; Fujinaga, K. *J. Electrochem. Soc.* **1989**, *136*, 1826.
- (57) Baldwin, A. C.; Davidson, I. M. T.; Howard, A. V. *J. Chem. Soc., Faraday Trans. I* **1975**, *71*, 972.
- (58) Garvey, P. M. *Generation and reaction of compounds containing germanium-carbon ( $\rho$ - $\rho$ )[ $\pi$ ] double bond*; Iowa State University: Ames, IA, 1973, pp pp38.
- (59) Mazerolles, P.; Manuel, G. *Bull. Soc. Chim. Fr.* **1966**, 327.
- (60) Mazerolles, P.; Gregoire, F. *J. Organometal. Chem.* **1986**, *301*, 153.
- (61) Poskozim, P. S. *J. Organometal. Chem.* **1968**, *12*, 115.
- (62) Fisher *J. Am. Chem. Soc.* **1954**, *76*, 5878.
- (63) Satge, J. *Compte. Rend.* **1959**, *249*, 131.
- (64) Satge, J.; Mathis-Noel, M.; Lesbre, M. *Compt. Rend.* **1959**, *249*, 131.
- (65) Miller, R. D.; Sooriyakumaran, R. *J. Polym. Sci. A.* **1987**, *25*, 111.
- (66) Satge, J. *Ann. Chim.(Paris)* **1961**, *6*, 519.
- (67) Fuchs, R.; Gilman, H. *J. Org. Chem.* **1958**, *23*, 911.
- (68) Lesbre, M.; Mazerolles, P.; Voigt, D. *Compte. Rend.* **1955**, *240*, 622.
- (69) Mazerolles, P.; Dubac, J. ; King, R. B. and Eisch, J. J., Ed.; Elsevier: New York, 1986, pp 555.
- (70) Brook, A. G.; Peddle, G. J. D. *J. Am. Chem. Soc.* **1963**, *85*, 1869.
- (71) Engel, J. P. *Gas phase thermochemistry of organogermanium compounds*; Iowa State University: Ames, IA, 1993, pp 26.



### Appendix. Deuterium incorporation data

Table 1. Deuterium incorporation data for hexenes produced from the flow pyrolysis of hexylgermane-d<sub>3</sub> 48D germanium coated surface.

substrate:	HexGeD <sub>3</sub>			
type:	flow / Ge surface		<u>product distribution</u>	<u>%</u>
T (°C):	400			
mmol sub:	0.642		1-hexene	76.2
[substrate]:	0.214		2-hexene	10.8
solvent:	toluene		3-hexene	5.1
			hexane	7.9
decomposition (%)	78.7			

Compound	Ion (M=84)	Actual Ion Intensity	Corrected Ion Intensity	Mol % deuteriated species	
1-hexene	M-2	--	--	--	
	M-1	--	--	--	
	M	24	24	85	(do)
	M+1	5	3	12	(d1)
	M+2	1	1	3	(d2)
	M+3	0	0	0	(d3)
2-hexene	M-2	--	--	--	
	M-1	--	--	--	
	M	28	28	61	(do)
	M+1	17	15	33	(d1)
	M+2	4	3	6	(d2)
	M+3	1	0	0	(d3)
3-hexene	M-2	--	--	--	
	M-1	--	--	--	
	M	32	32	64	(do)
	M+1	16	14	28	(d1)
	M+2	5	4	8	(d2)
	M+3	0	0	0	(d3)
hexane	Ion (M+86)				
	M-2	--	--	--	
	M-1	--	--	--	
	M	6	6	32	(do)
	M+1	13	13	68	(d1)
	M+2	1	0	0	(d2)

Table 2. Deuterium incorporation data for hexenes produced from the flow pyrolysis of dihexylgermane-d<sub>2</sub> **48D** over a germanium coated surface.

substrate:	Hex <sub>2</sub> GeD <sub>2</sub>		
type:	flow / Ge surface	<u>product distribution</u>	<u>%</u>
T (°C):	375		
mmol sub:	0.157	1-hexene	65.3
[substrate]:	0.052	2-hexene	19.7
solvent:	toluene	3-hexene	9.5
		hexane	5.6
decomposition (%)	86.1		

Compound	Ion (M=84)	Actual Ion Intensity	Corrected Ion Intensity	Mol % deuteriated species	
1-hexene	M-2	--	--	--	
	M-1	--	--	--	
	M	63747	63747	90	(do)
	M+1	10765	6369	9	(d1)
	M+2	1051	542	1	(d2)
	M+3	167	123	0	(d3)
2-hexene	M-2	--	--	--	
	M-1	--	--	--	
	M	45557	45557	75	(do)
	M+1	15219	12245	20	(d1)
	M+2	3391	2531	4	(d2)
	M+3	675	494	1	(d3)
3-hexene	M-2	--	--	--	
	M-1	--	--	--	
	M	22572	22572	76	(do)
	M+1	7278	5798	20	(d1)
	M+2	1593	1173	4	(d2)
	M+3	234	147	0	(d3)
hexane	Ion (M+86)				
	M-2	--	--	--	
	M-1	--	--	--	
	M	4336	11816	87	(do)
	M+1	2581	1800	13	(d1)
	M+2	227	97	1	(d2)

Table 3. Deuterium incorporation data for hexenes produced from the flow pyrolysis of dihexylgermane-d<sub>2</sub> **48D** over a silica surface.

substrate:	Hex <sub>2</sub> GeD <sub>2</sub>			
type:	flow / glass surface	<u>product distribution</u>		<u>%</u>
T (°C):	400			
mmol sub:	0.27	1-hexene	28.2	
[substrate]:	0.135	2-hexene	46.8	
solvent:	toluene	3-hexene	21.6	
		hexane	3.5	
decomposition (%)	70.3			

Compound	Ion (M=84)	Actual Ion Intensity	Corrected Ion Intensity	Mol % deuteriated species	
1-hexene	M-2	--	--	--	
	M-1	--	--	--	
	M	73352	73352	74	(do)
	M+1	24864	19806	20	(d1)
	M+2	6212	4766	5	(d2)
	M+3	1349	999	1	(d3)
2-hexene	M-2	--	--	--	
	M-1	--	--	--	
	M	89272	89272	67	(do)
	M+1	40744	34917	26	(d1)
	M+2	10780	8382	6	(d2)
	M+3	2116	1523	1	(d3)
3-hexene	M-2	--	--	--	
	M-1	--	--	--	
	M	51597	51597	67	(do)
	M+1	23677	20295	26	(d1)
	M+2	6014	4591	6	(d2)
	M+3	1183	846	1	(d3)
hexane	Ion (M+86)				
	M-2	--	--	--	
	M-1	--	--	--	
	M	8235	8235	72	(do)
	M+1	3701	3157	28	(d1)
	M+2	298	82	1	(d2)

Table 4. Deuterium incorporation data for hexenes produced from the flow pyrolysis of trihexylgermane-d 51D over a germanium coated surface.

substrate:	Hex <sub>3</sub> GeD			
type:	flow / Ge surface		<u>product distribution %</u>	
T (°C):	450			
mmol sub:	0.148	1-hexene	59.6	
[substrate]:	0.04	2-hexene	23.4	
solvent:	toluene	3-hexene	12	
		hexane	5.8	
decomposition (%)	98.9			

Compound	Ion (M=84)	Actual Ion Intensity	Corrected Ion Intensity	Mol % deuteriated species	
1-hexene	M-2	--	--	--	
	M-1	--	--	--	
	M	74122	74122	95	(do)
	M+1	8977	3866	5	(d1)
	M+2	653	305	0	(d2)
	M+3	0	0	0	(d3)
2-hexene	M-2	--	--	--	
	M-1	--	--	--	
	M	73468	73468	85	(do)
	M+1	16295	11499	13	(d1)
	M+2	2614	1766	2	(d2)
	M+3	308	177	0	(d3)
3-hexene	M-2	--	--	--	
	M-1	--	--	--	
	M	25215	25215	83	(do)
	M+1	5932	4279	14	(d1)
	M+2	983	657	2	(d2)
	M+3	117	66	0	(d3)
hexane	Ion (M+86)				
	M-2	--	--	--	
	M-1	--	--	--	
	M	6792	6792	86	(do)
	M+1	1586	1137	14	(d1)
	M+2	0	0	0	(d2)

Table 5. Deuterium incorporation data for hexenes produced from the flow pyrolysis of trihexylgermane-d 51D over a silica surface.

substrate:	Hex <sub>3</sub> GeD			
type:	flow / glass surface	<u>product distribution</u>		<u>%</u>
T (°C):	475			
mmol sub:	0.187	1-hexene	26.5	
[substrate]:	0.094	2-hexene	48.3	
solvent:	toluene	3-hexene	21.7	
		hexane	3.4	
decomposition (%)	82.6			

Compound	Ion (M=84)	Actual Ion Intensity	Corrected Ion Intensity	Mol % deuteriated species	
1-hexene	M-2	--	--	--	
	M-1	--	--	--	
	M	90464	90464	90	(do)
	M+1	15434	9196	9	(d1)
	M+2	1626	893	1	(d2)
	M+3	97	25	0	(d3)
2-hexene	M-2	--	--	--	
	M-1	--	--	--	
	M	224043	224043	80	(do)
	M+1	61528	46903	17	(d1)
	M+2	11613	8254	3	(d2)
	M+3	1613	1012	0	(d3)
3-hexene	M-2	--	--	--	
	M-1	--	--	--	
	M	94440	94440	83	(do)
	M+1	23357	17166	15	(d1)
	M+2	3517	2223	2	(d2)
	M+3	401	225	0	(d3)
hexane	Ion (M+86)				
	M-2	--	--	--	
	M-1	--	--	--	
	M	10474	10474	90	(do)
	M+1	1874	1182	10	(d1)
	M+2	--	--	--	(d2)

Table 6. Deuterium incorporation data for hexenes produced from the flow pyrolysis of trihexylgermane **51** over a silica surface.

substrate:	Hex <sub>3</sub> GeH			
type:	flow / glass surface	<u>product distribution</u>		<u>%</u>
T (°C):	500			
mmol sub:	0.197	1-hexene	22.9	
[substrate]:	0.131	2-hexene	46.3	
solvent:	toluene-D <sub>8</sub>	3-hexene	25.6	
		hexane	5.2	
decomposition (%)	75.2			

Compound	Ion (M=84)	Actual Ion Intensity	Corrected Ion Intensity	Mol % deuteriated species	
1-hexene	M-2	--	--	--	
	M-1	--	--	--	
	M	70586	70586	99	(do)
	M+1	5280	413	1	(d1)
	M+2	155	49	0	(d2)
	M+3	--	--	--	(d3)
2-hexene	M-2	--	--	--	
	M-1	--	--	--	
	M	261024	261024	99	(do)
	M+1	20632	3593	1	(d1)
	M+2	4	3	6	(d2)
	M+3	--	--	--	(d3)
3-hexene	M-2	--	--	--	
	M-1	--	--	--	
	M	151672	151672	99	(do)
	M+1	11808	1865	1	(d1)
	M+2	520	127	0	(d2)
	M+3	--	--	--	(d3)
hexane	Ion (M+86)				
	M-2	--	--	--	
	M-1	--	--	--	
	M	16375	16375	100	(do)
	M+1	1161	78	0	(d1)
	M+2	1	0	0	(d2)

Table 7. Deuterium incorporation data for hexenes produced from the FVP of hexylgermane-d<sub>3</sub> **48D** over a germanium coated surface.

substrate:	HexGeD <sub>3</sub>			
type:	FVP / Ge surface		<u>product distribution</u> %	
T (°C):	470			
mmol sub:	1.2121		1-hexene	86.7
[substrate]:			2-hexene	6
solvent:	-		3-hexene	3.3
			hexane	4
decomposition (%)	70			

Compound	Ion (M=84)	Actual Ion Intensity	Corrected Ion Intensity	Mol % deuteriated species	
1-hexene	M-2	--	--	--	
	M-1	--	--	--	
	M	218400	218400	90	(do)
	M+1	33600	18540	8	(d1)
	M+2	8400	6882	3	(d2)
	M+3	0	0	0	(d3)
2-hexene	M-2	--	--	--	
	M-1	--	--	--	
	M	20160	20160	57	(do)
	M+1	12960	11644	33	(d1)
	M+2	4320	3533	10	(d2)
	M+3	0	0	0	(d3)
3-hexene	M-2	--	--	--	
	M-1	--	--	--	
	M	18000	18000	61	(do)
	M+1	9600	8420	29	(d1)
	M+2	3600	3016	10	(d2)
	M+3	0	0	0	(d3)
hexane	Ion (M+86)				
	M-2	--	--	--	
	M-1	--	--	--	
	M	6600	6600	52	(do)
	M+1	6600	6164	48	(d1)
	M+2	1200	787	6	(d2)

### CHAPTER 3. EXAMINATION OF THE THERMAL BEHAVIOR DIALYLDIMETHYLGERMANE

#### Abstract

The flow pyrolysis of diallyldimethylgermane (1) was investigated. Arrhenius parameters of  $E_a = 54.2 \pm 0.8$  kcal/mol and  $\log A = 13.36 \pm 0.2$  were measured. The main decomposition pathway is proposed to be through consecutive Ge-C homolytic cleavage of the allyl groups.

#### Introduction

While the kinetics and mechanism of the thermal decomposition of diallyldimethylgermane (1) has not been previously reported, the silicon analog diallyldimethylsilane (2) has been investigated. Block and Revelle first reported the flash vacuum pyrolysis of diallyldimethylsilane (2), the major products of which were 1,1-dimethylsilacyclobutene (3) and propene<sup>1</sup> (Scheme 1). The reaction also produced some minor products the identity of which was not reported. The mechanism suggested by Block and Revelle was a retroene elimination of propene, producing a silabutadiene which cyclizes to form a silacyclobutene. The participation of a free radical mechanism was thought to be unlikely due to the absence of 1,5-hexadiene (from coupling of allyl radicals).

Scheme 1. Pyrolysis of diallyldimethylsilane (2).<sup>1</sup>

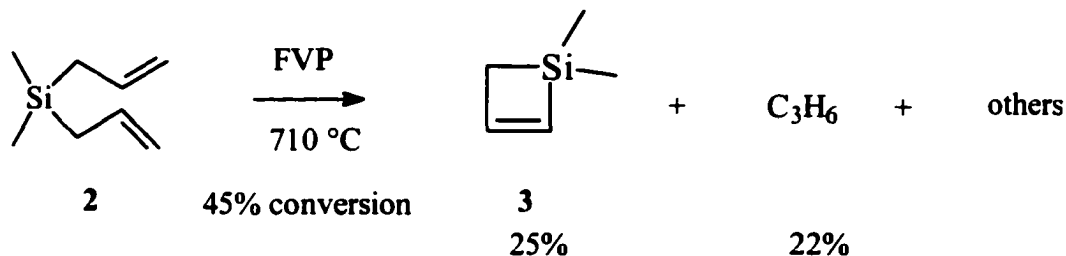



The thermal behavior of diallyldimethylsilane (**2**) is analogous to the behavior of allyltrimethylsilane (**5**), which was found to have competitive modes of decomposition: an intramolecular elimination, and a minor Si-C homolysis pathway, which leads to a radical chain mechanism.<sup>2</sup> The intramolecular process was found to be a retroene elimination of propene from silicon ( $E_a = 54.9$  kcal/mol,  $\log A = 11.6$ ). This apparently can occur in allyl containing silicon compounds as long as there is a  $\beta$  hydrogen. Scheme 2 shows the retroene elimination of propene from allyltrimethylsilane (**5**), giving dimethylsilene which dimerizes to give the disilacyclobutane **6**, or in the presence of 2,3-dimethyl-1,3-butadiene is trapped as silacyclohexene **7**.

Scheme 2. Retroene elimination of propene in the pyrolysis of allyltrimethylsilane (**5**).<sup>2</sup>

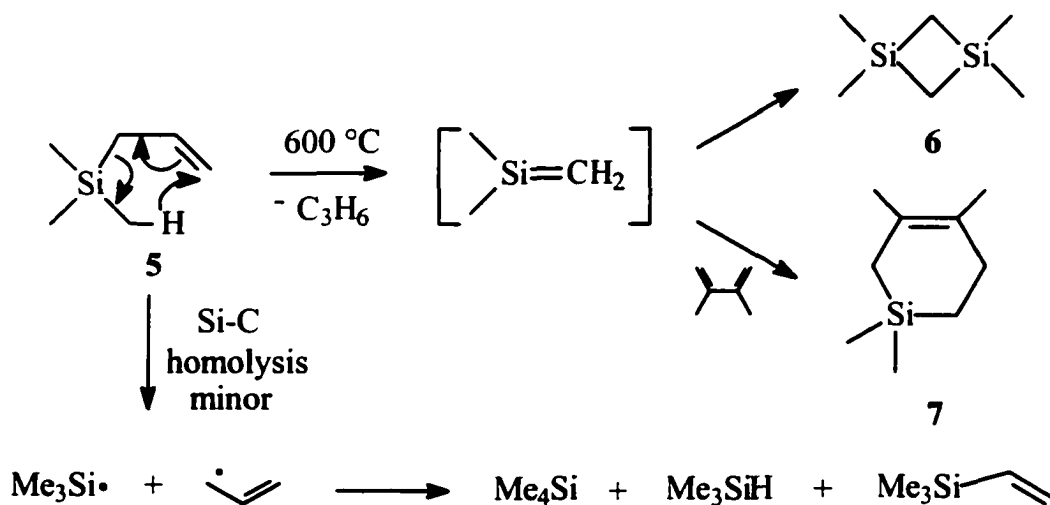

The Si-C homolysis ( $E_a = 73$  kcal/mol,  $\log A = 15.6$ , measured by trapping of the trimethylsilyl radical with chloromethane) pathway leads to the production of trimethylsilane, tetramethylsilane and trimethylvinylsilane through radical chain mechanisms. The amount of these products was found to be pressure dependant; at low pressures (0.05 torr) they are in fact not detectable. More detailed studies<sup>3</sup> on diallyldimethylsilane (**2**) would confirm that a radical mechanism was also occurring

in its pyrolysis. Using a SFR system, and low pressure pyrolysis with analysis by MS, the presence of the retroene product **3** (as observed by Block and Revelle) was confirmed. Kinetic measurements of the formation of propene in the pyrolysis of **2** gave Arrhenius parameters of  $\log A = 11.2 \pm 0.1$  and  $E_a = 47.56 \pm 0.5$ . Although the activation energy of 47.56 kcal/mol is somewhat lower than the  $E_a = 54.5$  kcal/mol reported for the retroene formation of propene from allyltrimethylsilane (**5**), this can largely be accounted for by allylic stabilization in **2**. These numbers are consistent with the retroene mechanism proposed. This work also revealed that in addition to **3**, other products were present. Three isomers of **2**, (**8-10**), were also produced in the pyrolysis. These isomers were not identified. However, their mass spectra indicated that there were no free allyl groups in the isomers, since they lack a large 99  $m/z+$  peak, which is present in **2**. The isomers were suggested to be the result of various intramolecular additions and to have cyclic structures. Other new products were also identified (shown in Table 1), which are consistent with a radical mechanism being operative as well.

Table 1. Products of the pyrolysis of diallyldimethylsilane (**2**) (1 torr at 723 K).<sup>3</sup>

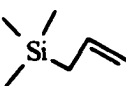
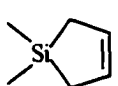
product	$C_2H_4$	$C_3H_6$	<b>3</b>			<b>8</b>	<b>9</b>	<b>10</b>
				<b>5</b>	<b>11</b>			
approx.								
rel. yld	1 <sup>a</sup>	8 <sup>a</sup>	5	1	1 <sup>b</sup>	3	3	1





<sup>a</sup> From GC peak areas in SFR; light hydrocarbons not quantitatively detected by GC-MS.

<sup>b</sup> Or isomer.

products in trace amounts:  $Me_2SiH_2$ ,  $Me_3SiH$ ,  $H(Me_2)Si(vinyl)$ , cyclopentadiene.

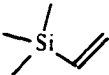
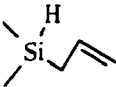
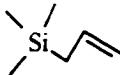
Davidson *et. al.*<sup>3</sup>

Table 2. Products from pyrolysis of **2** (5 torr at 763 K).<sup>3</sup>

product	approx. rel. yld.
Me <sub>3</sub> SiH	1
Me <sub>4</sub> Si	1
	1
	1
	0.5
<b>3</b>	5
	3
<b>5</b>	
	2 <sup>b</sup>
<b>11</b>	
	a, b
	2 <sup>b</sup>
<b>8</b>	3
<b>9</b>	3
<b>10</b>	1

<sup>a</sup> Trace quantity  
<sup>b</sup> Or isomer  
<sup>c</sup> relative to

This was illustrated by the effect of raising the pressure to 5 torr. The new products are shown in Table 2. As can be seen, the increase in pressure greatly increased the complexity of the pyrolysis due to secondary reactions that arise from the addition of radicals to **2**.

Davidson and coworkers proposed a mechanism that accounts for the main products observed. The mechanism consists, as already mentioned, of intramolecular processes that result in the silacyclobutene **3** and the three isomers of **2** (shown in Scheme 2), and of chain radical processes (shown in Scheme 3). The main product silacyclobutene **3**, as already mentioned, is the result of a retroene elimination of propene, giving a 1-sila-1,3-butadiene, which closes to the product **3**. The presence of the silabutadiene has been supported by the production of allylmethoxydimethylsilane in the presence of methanol.

Scheme 3. Intramolecular processes in the proposed mechanism of the pyrolysis of diallyldimethylsilane (**2**).<sup>3</sup>

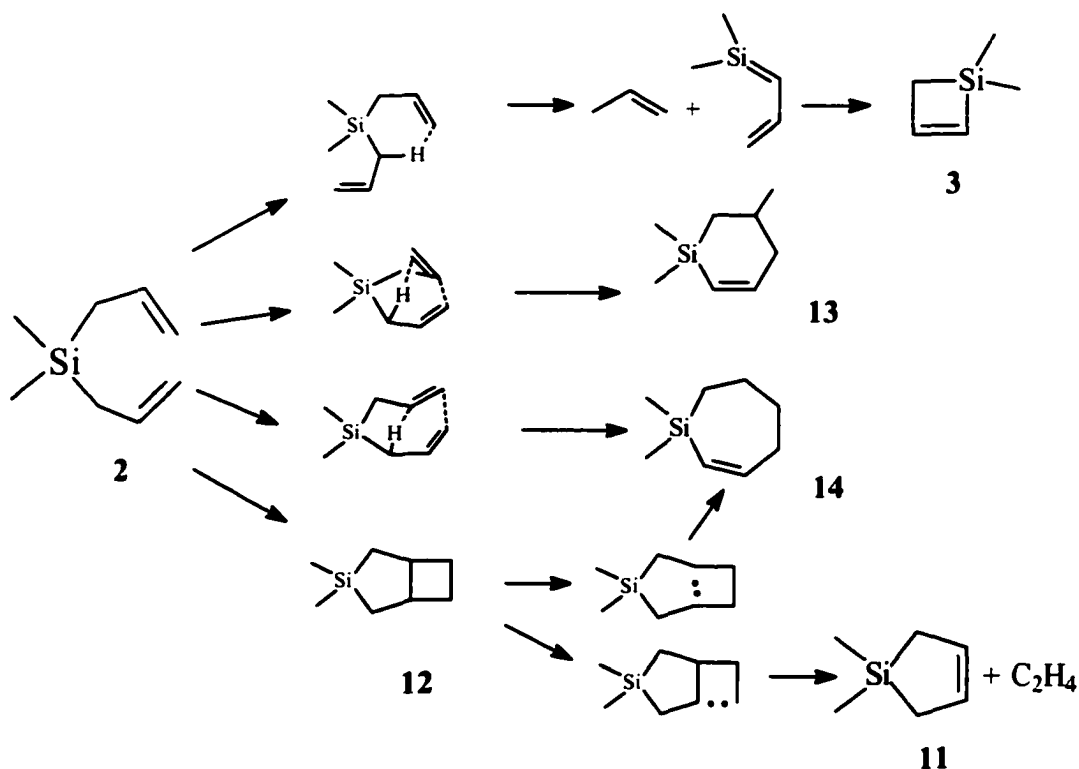

The products **12-14** are the result of intramolecular additions of the allyl groups, and presumably are the isomers **8-9**, although no accurate assignments were possible. The production of silacyclopentene **11**, is explained as the result of the elimination of ethylene from the bicyclic silane **10**.

Scheme 4 shows the processes responsible for many of the minor and trace products present in the pyrolysis due to secondary radical reactions. These products are reduced greatly under low pressure pyrolysis conditions. Dimethyl-(vinyl)silane, trimethylsilane, allyldimethyl(vinyl)silane, and allyltrimethyl-silane (**5**) are all shown to be products of the addition of either trimethylsilyl radical or allyldimethylsilyl radical to **2**.

Scheme 4. Radical processes in the proposed mechanism of the pyrolysis of (**2**).<sup>3</sup>

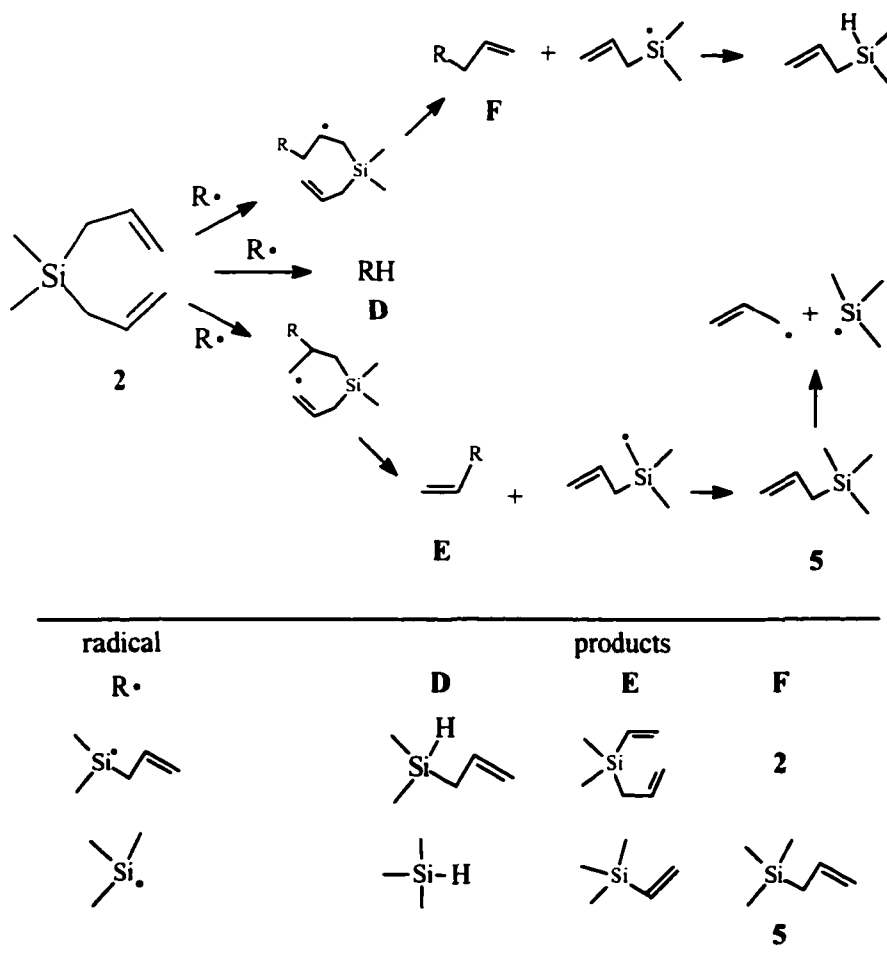

Tetramethylsilane, dimethylsilane, trimethyl(vinyl)silane, and dimethyl(vinyl)silane, while not shown in Scheme 4, are similarly the result of the addition of the above mentioned radicals to allyltrimethylsilane (**5**) or allyldimethylsilane.

The pyrolysis of allyl-containing germanium compounds has not been studied extensively (particularly the mechanism). However, there are some examples of the pyrolysis of allyl germanium-containing compounds. Mazerolles and coworkers examined allyltriethylgermane (**15**), diallyldiethylgermane (**16**), and tetraallylgermane (**17**).<sup>4</sup> This work focused on the products of the flow pyrolysis of these compounds and their suitability as CVD precursors. The products of these pyrolyses are shown in Table 3. No germanium containing products were reported, nor were any trapping experiments conducted.

Table 3. Volatile products of the flow pyrolysis of allylethylgermanes **15-17**.<sup>4</sup>

precursor	Temp(°C)*	products
<b>15</b>	300	propene, 1,5-hexadiene
<b>16</b>	400	ethylene, propene, 1,5-hexadiene
<b>17</b>	400	ethylene, propene

\* Temperature where decomposition is first observed.

Mechanistically, the following was proposed (see Scheme 5): propene was produced from the allyl groups, presumably through homolytic cleavage giving an allyl radical, followed by hydrogen abstraction. Ethylene was thought to evolve from radical reactions of the ethyl groups bound to germanium, perhaps again through homolytic cleavage. 1,5-Hexadiene was thought to be produced through one of two routes shown in Scheme 6. Although 1,5-hexadiene suggests a radical process, the dilution of the precursor is such (1:10<sup>4</sup>) that intermolecular processes were assumed

to be negligible. The mechanism suggested by Mazerolles indicates that 1,5-hexadiene is the result of the homocoupling of allyl radicals produced simultaneously from the precursor, or by the intramolecular addition of an allyl radical to the germanium radical species, giving a 1,3-diradical that undergoes  $\beta$  scission to produce diethylgermylene and 1,5-hexadiene.

Scheme 5. Proposed mechanism of ethylene and propene formation during diallyldiethylgermane (**16**) decomposition.<sup>4</sup>

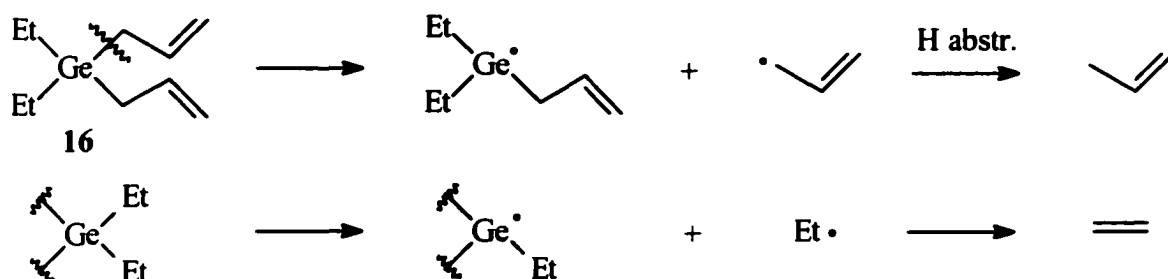

Scheme 6. Proposed mechanism of 1,5-hexadiene formation during diallyldiethylgermane (**16**) decomposition.<sup>4</sup>

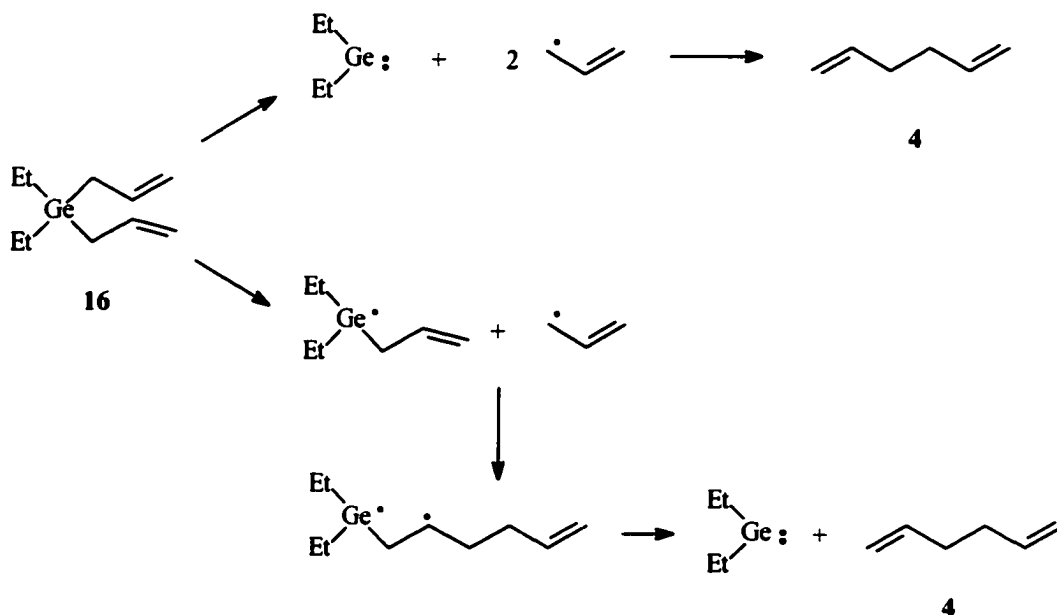

Note that the pyrolysis of allyltriethylgermane (**15**) yields only propene and ethylene, no 1,5-hexadiene, perhaps supporting the idea that it is produced through an intermolecular reaction.

A study of the pyrolysis of allyltrimethylgermane (**18**) was carried out in our labs.<sup>5</sup> Flow pyrolysis of the substrate at 550 °C in the presence of 2,3-dimethyl-1,3-butadiene yielded two products 1,1,3,4-tetramethyl-1-germacyclopent-3-ene (**19**) (21%), and trimethylgermane (**20**) (33%). Trimethylgermane **20** is most likely the result of the homolysis of the Ge-allyl bond to give trimethylgermyl radical, followed by hydrogen abstraction (Scheme 7). The production of **19** is indicative of the presence of dimethylgermylene, which is readily trapped by 2,3-dimethyl-1,3-butadiene to give the cyclic product.

Scheme 7. Pyrolysis of allyltrimethylgermane (**18**) in the presence of 2,3-dimethyl-1,3-butadiene.<sup>5</sup>

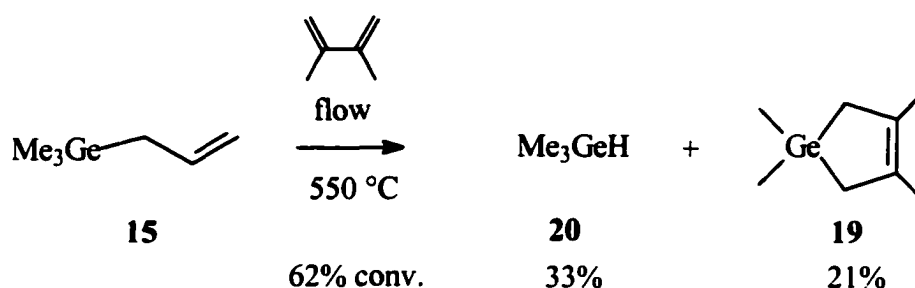

The mechanism of the formation of dimethylgermylene was proposed (as shown in Scheme 8) to be a concerted geminate elimination of 1,3-butadiene; of course the loss of a methyl radical from trimethylgermyl radical to give the dimethylgermylene also is possible. The kinetics or Arrhenius parameters of this pyrolysis were not measured.

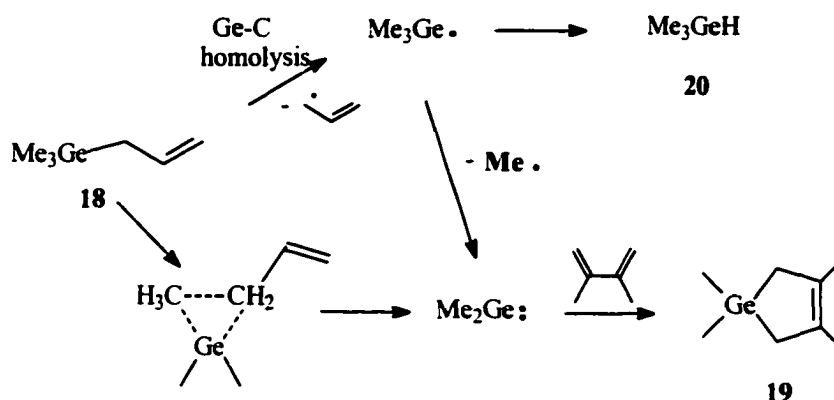

Scheme 8. Proposed mechanism of the pyrolysis of allyltrimethylgermane (**18**).<sup>5</sup>

## Results and Discussion

Diallyldimethylgermane (**1**) was synthesized according to literature methods and purified by distillation. The pyrolysis of **1** was thought most likely to decompose through one pathway or a combination of the pathways shown in Scheme 9. The retroene mechanism shown in the top pathway seems unlikely based on the literature available. However, since the 1,1-dimethylgermacyclobutene (**21**) is an unknown compound it may be possible that its thermal stability is not sufficient to allow its observation in the reported experiments, although the silicon analog is quite stable under thermal conditions. The inclusion of 2,3-dimethyl-1,3-butadiene in the pyrolysis may allow trapping of the intermediate germene, although the absence of such trapping does not necessarily mean that the rearrangement is not operative, since the trapping process would have to be competitive with the intramolecular ring closure to form the germacyclobutene. The bottom pathway is initiated by homolytic cleavage of a Ge-allyl bond, giving a germyl radical. Decomposition of this germyl radical, either through simple homolytic cleavage or through involvement of another radical as suggested in the literature, produces dimethylgermylene which can be trapped in the presence of 2,3-dimethyl-1,3-butadiene. With this in mind the pyrolysis of diallyldimethylgermane (**1**) was carried out in the presence of excess (64 fold) 2,3-dimethyl-1,3-butadiene (Scheme 10).

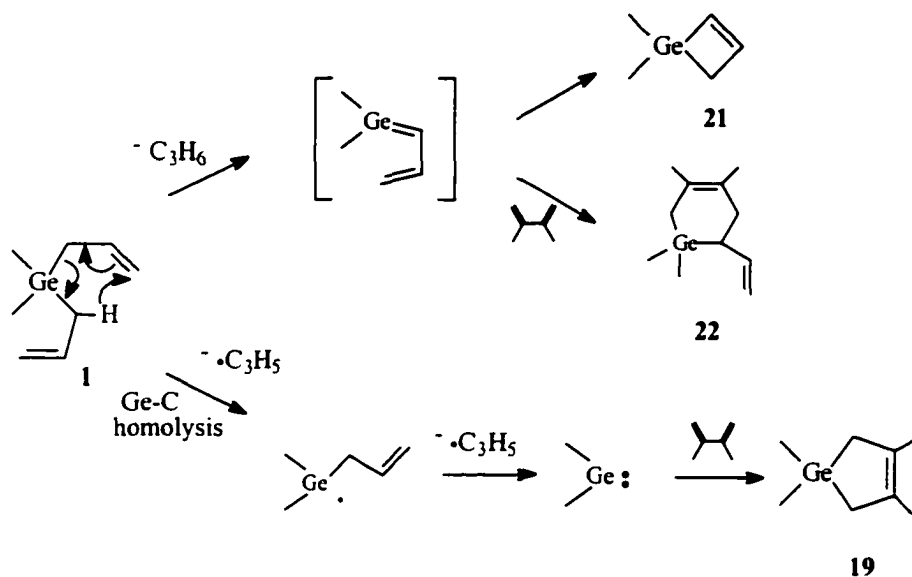
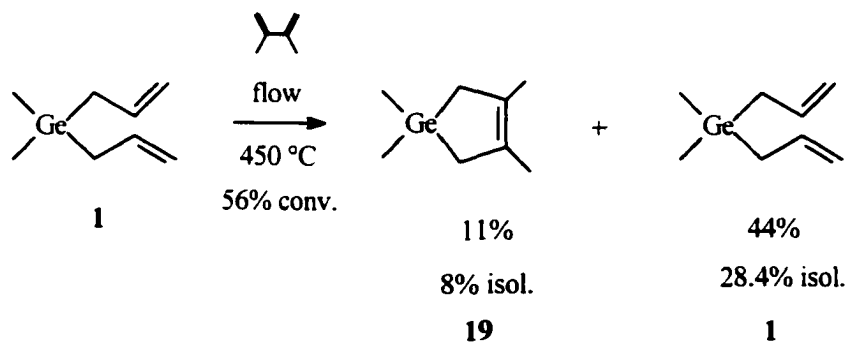
Scheme 9. Possible pyrolytic reaction pathways of diallyldimethylgermane (**1**).Scheme 10. Pyrolysis of diallyldimethylgermane (**1**) in the presence of 2,3-dimethyl-1,3-butadiene.

The pyrolysis was carried out under flow conditions, with the pyrolysate being trapped in a dry ice/acetone bath. No attempt was made to identify or trap the volatile hydrocarbon products. Conversion and GC yields of the product were determined by internal standard methods. The only germanium-containing product was 1,1,3,4-tetramethyl-1-germacyclopent-3-ene **19** (11% GC yield). Initially,

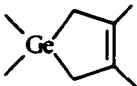
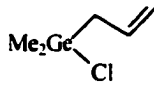
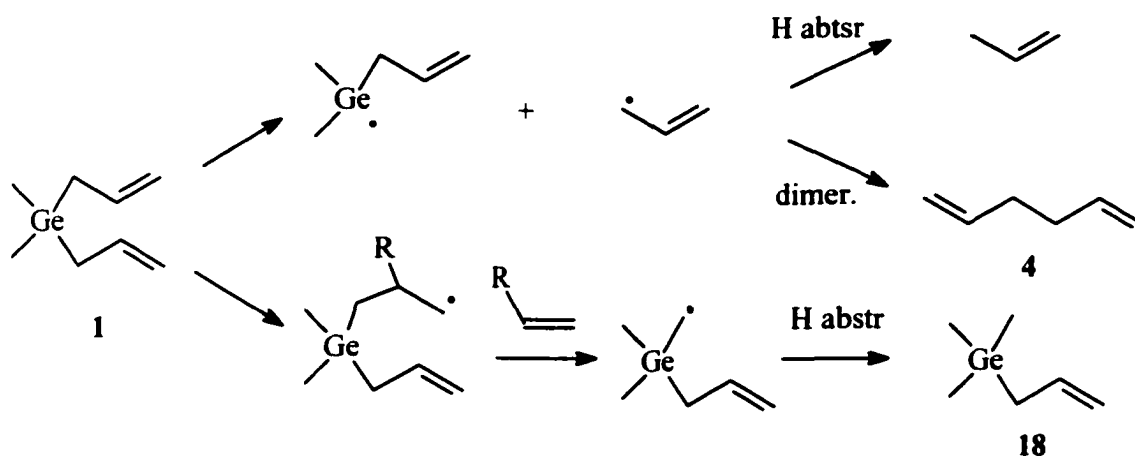

Table 4. Summary of diallyldimethylgermane (1) flow pyrolysis experiments.

Temp. (°C)	Decomp. (%)	Trap	Ge containing Products
550	100	DMBD	none
500	100	DMBD	none
450	56	DMBD	 11% 19
475	68	BuCl	$\text{Me}_3\text{GeCl}$ + $\text{Me}_2\text{GeCl}_2$ +  2.9%                      10.8%                      62.8% 23

The products were identified by analysis of the mass spectra and comparison to spectra of authentic material. The production of both propene and 1,5-hexadiene were confirmed. In addition, the presence of allyltrimethylgermane was noted, in surprisingly large amount, for the neat sample. In the samples with toluene only a trace of allyltrimethylgermane was present, and in addition the amount of 1,5-hexadiene was reduced. Since toluene can intercept radicals, it seems clear that the production of both 1,5-hexadiene and allyltrimethylgermane (18) are the result of radical processes. Similar chain radical processes have been proposed to explain the byproducts of the pyrolysis of diallyldimethylsilane (2) and allyltrimethylsilane (5). Scheme 12 shows the proposed mechanism.

Scheme 12. Proposed mechanism for the formation of propene, 1,5-hexadiene, and allyltrimethylgermane (**18**) during the pyrolysis of diallyldimethylgermane (**1**).



Propene is formed from the abstraction of a proton by an allyl radical, while 1,5-hexadiene (**4**) is most likely formed from homocoupling of the same. While Mazerolles discounted intermolecular reactions with his proposed mechanism for 1,5-hexadiene (**4**) formation, it seems that homocoupling best fits the data under our conditions. The allyltrimethylgermane (**18**) is formed through a chain mechanism that includes the anti-Markovnikov addition of a radical to the double bond of an allyl group. Subsequent homolysis of the adjacent C-C bond, followed by hydrogen abstraction would produce allyltrimethylgermane (**18**).

Scheme 13. SFR pyrolysis of diallyldimethylgermane (**1**) in the presence of 2,3-dimethyl-1,3-butadiene.

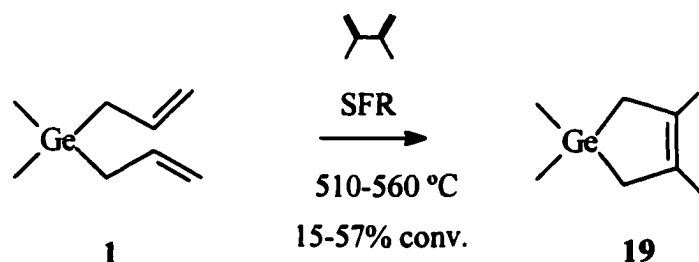

The Arrhenius parameters of the pyrolysis of diallyldimethylgermane (**1**) were measured. The parameters were measured by liquid injection, in a solution of excess (34 fold) 2,3-dimethyl-1,3-butadiene, using a SFR-GC system. The formation of the trapping product 1,1,3,4-tetramethyl-1-germacyclopent-3-ene was used to calculate rate constants for the temperature range 510-560 °C (15-57% decomposition), with 20 data points collected. The following parameters were obtained:  $E_a = 54.22 \pm 0.8$  kcal/mol and  $\log A = 13.36 \pm 0.2$ . The  $E_a$  obtained is less than that reported for the similar (minor) pathway of allyl homolysis in allyltrimethylsilane (**5**) ( $E_a = 73$  kcal/mol,  $\log A = 15.6$ ). However, this is not unexpected because of the weaker Ge-C bond energy. The Si-C bond energy has been reported to be 89 kcal/mol<sup>6</sup>, while the Ge-C bond energy is most likely around 74 kcal/mol.<sup>7-9</sup> The stabilizing effect of the allyl radical for the silicon analog is roughly 16 kcal/mol, based on the accepted Si-C bond strength and the reported  $E_a$  for homolytic cleavage of an allyl group from **8**. Thus, the reported activation energy of 54 kcal/mol for **1** is not unreasonable for homolytic cleavage of the allyl group from germanium as the rate-determining step, although the  $\log A$  of 13.36 is not representative for a typical homolytic process. The entropy of activation of  $-1.3$ , suggests that the transition state involved is more constrained than that of the original configuration. However, the large error limit of  $\pm 0.9$  may mean that the real change is quite small. Nevertheless, the entropy of activation does not appear to be that of a simple homolytic cleavage. For example, the reported value is quite different than  $S^\ddagger = 8.8$  (at 813.16 K) for the homolytic cleavage of an allyl group in allyltrimethylsilane, nor is it similar to the  $S^\ddagger = -9.45$  (at 813.16 K) reported for the retroene mechanism in allyltrimethylsilane decomposition.<sup>2</sup>

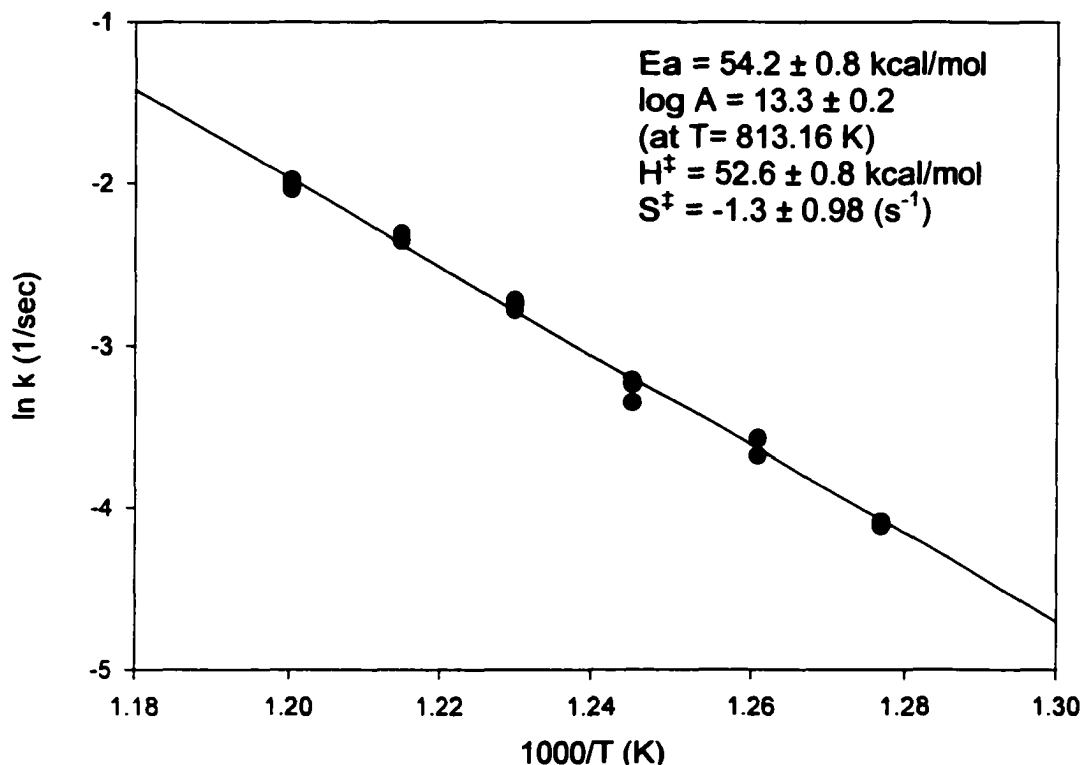

Figure 1. Arrhenius plot for the thermal decomposition of **1** following the formation of germacyclopenta-3-ene **19**.

### Conclusion

While much of the data points to a stepwise homolytic cleavage mechanism for the decomposition of diallyldimethylgermane (**1**), it is possible that the atypical value for  $\log A$  that was obtained can be explained by a minor decomposition pathway that is occurring along with homolytic cleavage. As mentioned previously, if the expected product of retroene rearrangement, 1,1-dimethylgermacylobutene (**21**), is thermally unstable under the reaction conditions *and* the intermediate germabutadiene cannot be trapped, then there would be no directly observable evidence of the rearrangement occurring. Therefore, the most likely (and at least

the major) mechanism for the pyrolysis of diallyldimethylgermane is summarized in Scheme 14.

Scheme 14. Mechanism of diallyldimethylgermane (**1**) decomposition.

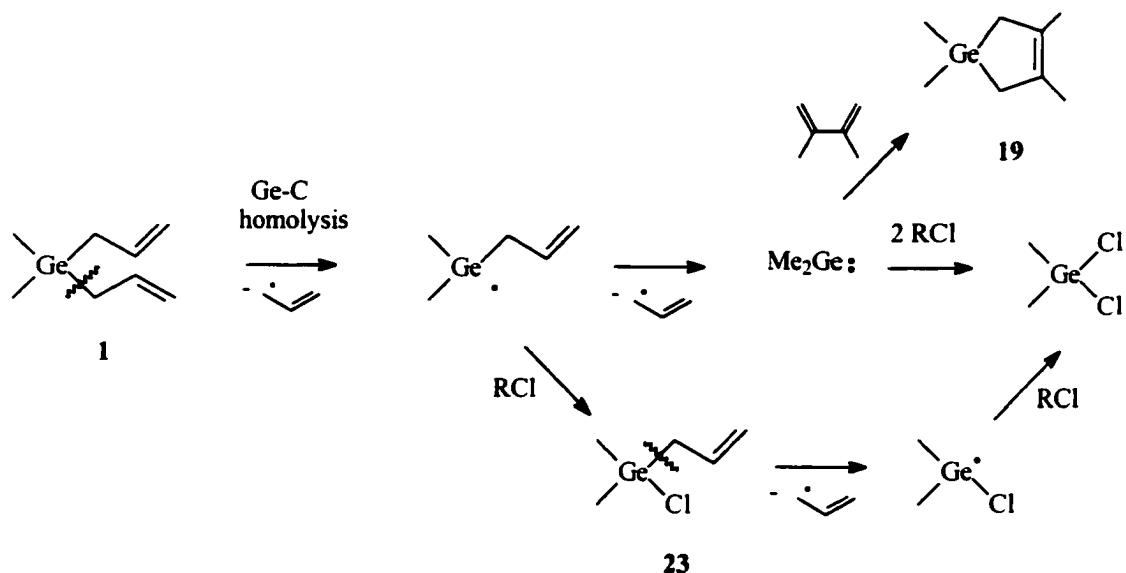

The first step, homolytic cleavage of a Ge-C bond, yields an allyl radical and a germyl radical. This resulting allyldimethylgermyl radical can then undergo consecutive loss of an allyl radical giving dimethylgermylene. The germylene can be trapped with 2,3-dimethyl-1,3-butadiene. If no trap is present no doubt the ultimate fate of germanium is as a film on the reactor walls. In the presence of an alkyl chloride, the intermediate allyldimethylgermyl radical can be trapped, giving allyldimethylchlorogermine (**23**). After loss of another allyl radical, the trapping can be repeated, finally giving dimethyldichlorogermine. It should be noted that dimethylgermylene does not insert into alkyl chloride bonds and quite correctly, no insertion products are observed in this trapping experiment.



## Experimental Section

Preparative gas chromatography was carried out on a Varian 920 gas chromatograph equipped with thermal conductivity detector and a chart recorder using the column indicated. Helium was used as the carrier gas.

A pulsed-stirred flow reactor was used for the kinetic measurements, which is similar to the previously described design of Baldwin et. al.<sup>10</sup> The SFR reactor consisted of a quartz reactor with a volume of 4 cm<sup>3</sup>. The reactor was heated by an oven controlled by a Digi-Sense temperature controller. The reactor was connected to a Varian 6000 gas chromatograph (30m DB-5 Megabore column, FID detector) by heated transfer line. Data was recorded on a Hewlett Packard 3390A integrator and a Magnum XT/Mark 2 microcomputer. Helium was used (60 mL/min flow rate) as the carrier gas.

Flow pyrolysis was carried out using a vertical 50 cm quartz tube (interior diameter of 15 mm) packed with quartz chips. The tube was heated by an oven controlled by a Digi-Sense temperature controller.

<sup>1</sup>H and <sup>13</sup>C NMR spectra were acquired on a Varian VXR-300 spectrometer. Chemical shifts are reported in parts per million with the indicated solvent as standard. Proton splitting is reported using standard abbreviations. Routine infrared spectra are reported in wavenumbers (cm<sup>-1</sup>) and were obtained on a Bio-Rad Digilab FTS-7 spectrometer from a neat sample (except where noted). Other IR spectra were obtained on a Hewlett Packard GC-IR-MS (GC: HP 5890, IR: HP 5965A, MSD: HP 5970). UV/Vis spectra were obtained using a Hewlett Packard 8452A diode array UV/Vis spectrometer. Mass spectra are reported as m/z (relative intensity) and were obtained on the previously described GC-MS-IR or a Hewlett Packard GC-MS (GC: HP 5890 series II, MSD: HP 5972). Exact masses were acquired on a Kratos MS 50 mass spectrometer. Quantitative gas chromatography was performed on a Hewlett Packard 5890 series II GC equipped with a flame ionization detector. Except where indicated a 30 m, 0.25 mm i.d. capillary column with DB-5 stationary phase was utilized for all gas chromatography. The carrier gas used was helium.

THF and ether were distilled over sodium-benzophenone right before use. For rigorous drying, THF was subjected to a second distillation over lithium aluminum hydride before use. Other reagents were used as received (without further purification) from Aldrich, Fisher Chemical, or Gelest except where indicated.

**1,1,3,4-Tetramethyl-1-germacyclopent-3-ene (19).** This compound was made according to the literature.<sup>11</sup> A solution of germanium diiodide (3.27 g, 10 mmol), 2,3-dimethyl-1,3-butadiene (1.1 g, 1.52 mL, 13 mmol), and hexane (10 mL) was sealed in a vessel and stirred for 8 h at room temperature, then heated to 60 °C for 4 h. Next the reaction mixture was transferred to a flask containing methylmagnesium chloride (20 mL, 60 mmol, 3.0 M in ether) at -78 °C and stirred for 15 min. The reaction mixture was warmed to room temperature and stirred for 2 h. The reaction mixture was then quenched in HCl (2 M, 100 mL) and extracted with pentane (2 x 75 mL). The combined organic layer was washed with sat. sodium bicarbonate (75 mL), water (75 mL), and sat. sodium chloride (75 mL) then dried over magnesium sulfate. After solvent removal *in vacuo*, distillation gave **19** (1.8 g, 9.7 mmol, 97%) as a clear liquid (b.p. 51-53 °C/8 torr, lit. b.p. 88 °C/45 torr<sup>11</sup>). <sup>1</sup>H NMR (CDCl<sub>3</sub>) δ 1.71 (t, *J* = 1.0 Hz, 6H, ~CH<sub>2</sub>(CH<sub>3</sub>)C=C~), 1.52 (d, *J* = 1.0 Hz, 4H, ~CH<sub>2</sub>(CH<sub>3</sub>)C=C~), 0.30 (s, 6H, ~Ge(CH<sub>3</sub>)<sub>2</sub>); <sup>13</sup>C NMR (CDCl<sub>3</sub>) δ 130.9, 26.9, 19.4, -2.2; IR (neat, cm<sup>-1</sup>) 2986, 2905, 1820, 1446, 1385, 1248, 1167, 942, 892, 830, 796; GC-MS (EI): *m/z* 188 (11), 187 (5), 186 (M<sup>+</sup>, 55), 185 (42), 182 (31), 173 (21), 172 (8), 171 (100), 170 (28), 169 (76), 167 (57), 143 (8), 141 (6), 139 (5), 129 (12), 127 (10), 125 (7), 115 (5), 113 (7), 111 (5), 106 (9), 105 (7), 104 (43), 103 (16), 102 (32), 101 (8), 100 (25), 99 (5), 97 (4), 91 (14), 89 (64), 88 (17), 85 (37), 75 (4), 73 (4), 67 (4); HRMS (EI) *m/z* calcd for C<sub>8</sub>H<sub>16</sub>Ge 185.04866, found 185.04898.

**Diallyldimethylgermane (1).** This compound was made using a method similar to that of Petrow.<sup>12</sup> A flask was charged with allylmagnesium chloride (168 mL, 336 mmol, 2 M in THF) and dry THF (200 mL) and cooled to -78 °C. An addition funnel was charged with of a mixture of dimethyldichlorogermane and methyltrichlorogermane (21.8 g, approx. 112 mmol). The mixture was added dropwise with mechanical stirring. Upon completion of addition the reaction mixture

was warmed to room temperature and stirred for 3 h. The reaction mixture was then quenched in chilled dilute HCl (200 mL), then extracted with pentane (3 x 100 mL). The combined organic portion was washed repeatedly with dilute HCl (8 x 100 mL) to remove THF. The organic portion was further washed with sat. sodium bicarbonate (100 mL), water (100 mL), and sat. sodium chloride (100 mL) then dried over magnesium sulfate. The solvent was removed by distillation through a 25 cm column packed with glass helices. Isolation was performed on the same column at reduced pressure (20 torr). This gave dimethyldiallylgermane (8.1 g, 43.5 mmol, 39%) as a clear liquid (b.p. 47-50 °C/20 torr), and triallylmethylgermane (**24**) (9 g, 42.5 mmol, 38%) as a clear liquid (b.p. 71-75 °C/20 torr). The total yield was approximately 77%. (**1**):  $^1\text{H}$  NMR ( $\text{CDCl}_3$ )  $\delta$  5.82 (ddt,  $J = 17.0, 6.8, 1.7$  Hz, 2H,  $\sim\text{Ge}(\text{CH}_2(\text{H})\text{C}=\text{CH}_2)_2$ ), 4.83 (m, 4H,  $\sim\text{Ge}(\text{CH}_2(\text{H})\text{C}=\text{CH}_2)_2$ ), 1.6 (dt,  $J = 7.0, 0.8$  Hz, 4H,  $\sim\text{Ge}(\text{CH}_2(\text{H})\text{C}=\text{CH}_2)_2$ ), 0.14 (s, 6H,  $\sim\text{Ge}(\text{CH}_3)_2$ );  $^{13}\text{C}$  NMR ( $\text{CDCl}_3$ )  $\delta$  135.7, 112.3, 22.3, -4.8; IR (neat,  $\text{cm}^{-1}$ ) 3078, 2971, 2900, 1790, 1620, 1422, 1236, 1192, 1141, 1034, 989, 930, 891, 810, 687; GC-MS (EI):  $m/z$  186 ( $\text{M}^+$ , 1), 184 (1), 171 (4), 170 (1), 169 (3), 167 (2), 147 (21), 146 (7), 145 (100), 144 (29), 143 (77), 141 (57), 129 (4), 127 (3), 115 (6), 113 (6), 111 (5), 107 (11), 105 (49), 104 (16), 103 (39), 101 (32), 99 (6), 97 (4), 91 (14), 89 (62), 88 (19), 87 (47), 85 (34), 75 (6), 74 (5), 73 (5), 72 (3); HRMS (EI)  $m/z$  calcd for  $\text{C}_8\text{H}_{16}\text{Ge}$  184.04751, found 184.04728. (**24**):  $^1\text{H}$  NMR ( $\text{CDCl}_3$ )  $\delta$  5.82 (ddt,  $J = 17.0, 6.8, 1.7$  Hz, 3H,  $\sim\text{Ge}(\text{CH}_2(\text{H})\text{C}=\text{CH}_2)_3$ ), 4.83 (m, 6H,  $\sim\text{Ge}(\text{CH}_2(\text{H})\text{C}=\text{CH}_2)_3$ ), 1.6 (dt,  $J = 7.0, 0.8$  Hz, 6H,  $\sim\text{Ge}(\text{CH}_2(\text{H})\text{C}=\text{CH}_2)_3$ ), 0.14 (s, 3H,  $\sim\text{GeCH}_3$ );  $^{13}\text{C}$  NMR ( $\text{CDCl}_3$ ) 135.4, 112.8, 20.6, -6.8; IR (neat,  $\text{cm}^{-1}$ ) 3077, 2970, 2931, 2858, 1791, 1621, 1422, 1396; GC-MS (EI):  $m/z$  198 (2), 173 (18), 172 (7), 171 (83), 170 (25), 169 (63), 167 (46), 158 (4), 145 (5), 143 (20), 142 (6), 141 (15), 139 (11), 131 (14), 130 (5), 129 (39), 128 (10), 127 (30), 125 (20), 115 (26), 114 (7), 113 (22), 111 (17), 103 (5), 101 (15), 99 (12), 97 (9), 91 (23), 89 (100), 88 (26), 87 (76), 85 (55), 81 (5), 79 (7), 75 (5), 74 (4), 73 (4).

**Pyrolysis of dimethyldiallylgermane (1) in the presence of 2,3-dimethyl-1,3-butadiene.** A solution of diallyldimethylgermane (**1**) (0.25 g, 1.34 mmol) in 2,3-dimethyl-1,3-butadiene (7.6 mL) with heptane (0.045 g) as an internal standard was

prepared. Flow pyrolysis was carried out at 450 °C using a 50 cm packed vertical column with a 60 mL/min He flow. The pyrolysate was collected in a trap at -78 °C. The degree of conversion was calculated base on the remaining starting material (109.8 mg, 0.59 mmol, 44% by internal standard method) and was 56%, with the only product being 1,1,3,4-tetramethyl-1-germacyclopent-3-ene (**19**) (27.6 mg, 0.1482 mmol, 11% by internal standard method). The product was isolated by preparative GC (8 ft ¼ inch diameter column packed with 14% SE-30 on chromosorb-WHP, Isothermal at 110 °C with a 130 °C injector temperature, flow rate of 55 mL/min He) giving the product **19** (20 mg, 0.107 5 mmol, 8%) as a clear liquid. <sup>1</sup>H NMR (CDCl<sub>3</sub>) δ 1.7 (s, 6H, ~CH<sub>2</sub>(CH<sub>3</sub>)C=C~), 1.5 (d, *J* = 0.9 Hz, 4H, ~CH<sub>2</sub>(CH<sub>3</sub>)C=C~), 0.28(s, 6H, ~Ge(CH<sub>3</sub>)<sub>2</sub>); <sup>13</sup>C NMR (CDCl<sub>3</sub>) δ 130.9, 26.9, 19.5, -2.2; IR (neat, cm<sup>-1</sup>) 2980, 2905, 1827, 1692, 1447, 1387, 1245, 1168, 1112, 974, 851, 796; GC-MS (EI): *m/z*: 188 (7), 186 (M<sup>+</sup>, 34), 185 (10), 184 (25), 182 (19), 173 (14), 172 (6), 171 (68), 170 (21), 169 (54), 167 (41), 143 (7), 141 (6), 139 (5), 129 (11), 127 (9), 125 (7), 115 (6), 113 (8), 111 (7), 106 (11), 105 (10), 104 (57), 103 (21), 102 (42), 101 (12), 100 (34), 99 (8), 97 (6), 91 (21), 89 (100), 88 (28), 87 (77), 85 (59), 79 (5), 77 (6), 75 (7), 74 (6), 73 (6), 71 (4), 67 (11), 54 (4), 53 (8), 51 (4); HRMS (EI) *m/z* calcd for C<sub>8</sub>H<sub>16</sub>Ge 182.04950, found 182.04947.

**Pyrolysis of dimethyldiallylgermane (1) in the presence of *n*-butyl chloride.** A solution of diallyldimethylgermane (**1**) (0.16 g, 0.86 mmol) in *n*-butyl chloride (4 mL) with of heptane (0.0124 g) as an internal standard was prepared. Flow pyrolysis was carried out at 475 °C using a 50 cm packed vertical column with a 60 mL/min He flow. The pyrolysate was collected in a trap cooled to -78 °C in a dry ice/isopropyl alcohol bath. The GC yields were calculated using the internal standard method, product identification was carried out by MS comparison to known compounds. The products were trimethylchlorogermane (2%), dimethyldichlorogermane (10.8%), allyldimethylchlorogermane (**23**) (62.8%) and diallyldimethylgermane (**1**) (23.5%). The conversion was 76.5% based on the remaining starting material.

**Me<sub>3</sub>GeCl.** GC-MS (EI): *m/z* 156 (1), 154 (M<sup>+</sup>, 4), 153 (1), 152 (2), 150 (2), 143 (6), 141 (45), 140 (8), 139 (100), 138 (21), 137 (75), 135 (45), 126 (3), 125 (2), 124 (7), 123 (4), 122 (6), 121 (16), 120 (6), 119 (61), 118 (16), 117 (44), 115 (33), 111 (9), 109 (22), 108 (4), 107 (15), 105 (9), 104 (5), 102 (4), 101 (2), 100 (3), 99 (3), 91 (9), 90 (3), 89 (23), 88 (9), 87 (19), 86 (5), 85 (10), 84 (3), 75 (5), 74 (7), 73 (5), 72 (36), 70 (3), 67 (3), 56 (6), 54 (3).

**Me<sub>2</sub>GeCl<sub>2</sub>.** GC-MS (EI): *m/z* 176 (6), 175 (1), 174 (M<sup>+</sup>, 9), 173 (2), 172 (7), 170 (4), 163 (15), 161 (61), 160 (11), 159 (100), 158 (16), 157 (74), 155 (37), 141 (12), 140 (3), 139 (3), 138 (7), 137 (21), 135 (13), 124 (4), 123 (3), 122 (4), 121 (2), 120 (2), 113 (2), 111 (13), 110 (2), 109 (31), 108 (6), 107 (23), 105 (14), 89 (14), 88 (4), 87 (7), 86 (3), 85 (5), 74 (4), 73 (2), 72 (3), 70 (2).

**23.** GC-MS (EI): *m/z* 182 (2), 181 (1), 180 (M<sup>+</sup>, 6), 179 (1), 178 (4), 176 (3), 165 (3), 163 (2), 147 (3), 145 (12), 144 (3), 143 (14), 142 (2), 141 (49), 140 (9), 139 (100), 138 (21), 137 (75), 135 (45), 126 (2), 125 (2), 124 (5), 123 (3), 122 (4), 121 (12), 120 (2), 113 (3), 111 (9), 110 (2), 109 (18), 108 (4), 107 (15), 105 (14), 104 (3), 103 (6), 101 (5), 91 (4), 90 (1), 89 (17), 88 (6), 87 (13), 86 (2), 85 (9), 75 (2), 74 (3), 73 (2), 72 (2).

**1.** GC-MS (EI): *m/z* 186 (M<sup>+</sup>, 1), 184 (1), 173 (1), 171 (4), 170 (1), 169 (3), 167 (2), 147 (21), 146 (6), 145 (100), 144 (27), 143 (78), 141 (59), 129 (4), 128 (1), 127 (3), 125 (2), 117 (2), 115 (5), 114 (2), 113 (6), 112 (2), 111 (5), 110 (1), 109 (2), 108 (1), 107 (10), 106 (2), 105 (49), 104 (14), 103 (39), 102 (3), 101 (33), 99 (5), 97 (3), 91 (14), 90 (2), 89 (58), 88 (16), 87 (44), 86 (3), 85 (33), 81 (2), 80 (3), 75 (5), 74 (4), 73 (4), 72 (2), 71 (3), 70 (2).

**References**

- (1) Block, E.; Revelle, L. K. *J. Am. Chem. Soc.* **1978**, *100*, 1630.
- (2) Barton, T. J.; Burns, S. A.; Davidson, I. M. T.; Ijadi-Maghsoodi, S.; Wood, I. T. *J. Am. Chem. Soc.* **1984**, *106*, 6367.
- (3) Auner, N.; Davidson, I. M.; Ijadi-Maghsoodi, S. *Organometallics* **1985**, *4*, 2210.
- (4) Mazerolles, P. *Silicon, Germanium, Tin and Lead Compounds* **1986**, *9*, 155.
- (5) Engel, J. P. *Gas phase thermochemistry of organogermanium compounds*; Iowa State University: Ames, 1993, pp 104.
- (6) Walsh, R. *Acc. Chem. Res.* **1981**, *14*, 246.
- (7) Jackson, R. A. *J. Organometal. Chem.* **1979**, *166*, 17.
- (8) Dzarnoski, J.; Ring, M. A.; O'Neal, H. E. *Int. J. Chem. Kinet.* **1981**, *14*, 279.
- (9) Smith, G. P.; Patrick, R. *Int. J. Chem. Kinet.* **1983**, *15*, 167.
- (10) Baldwin, A. C.; Davidson, I. M. T.; Howard, A. V. *J. Chem. Soc., Faraday Trans. I* **1975**, *71*, 972.
- (11) Takeuchi, Y.; Tanaka, K.; Harazono, T. *Bull. Chem. Soc. Jpn.* **1991**, *64*, 91.
- (12) Petrow; al., e. *Izv. Akad. Nauk. SSSR Ser. Khim.* **1956**, 1169.

## CHAPTER 4. STUDY OF A NOVEL METHYLENESILACYCLOBUTENE

### Abstract

The thermal and photolytic behavior of (*Z*)-1,1-dimethyl-2-phenyl-4-(phenylmethylene)silacyclobut-2-ene (**4**), were studied in the hopes that a rare 1,2-silicon rearrangement to a carbene would be observed. Photolysis at 350 nm or thermolysis in a sealed tube at 250 °C gave the same product, apparently through *cis-trans* isomerization of the external phenylmethylene moiety. Thus, the result was inevitably an inseparable mixture of (*E*)-1,1-dimethyl-2-phenyl-4-(phenylmethylene)silacyclobut-2-ene (**33**) and **4** in a 1:1 ratio. Derivatization of the compounds through alcoholysis for the purposes of characterization produced ring-opened products (*E,Z*)-1,4-diphenyl-1-(ethoxydimethylsilyl)-1,3-butadiene (**31**), and (*E,E*)-1,4-diphenyl-2-(ethoxydimethylsilyl)-1,3-butadiene (**36**), which also proved to be inseparable.

### Introduction

As discussed in Chapter 1, the thermal isomerization of 1,1-dimethyl-2-methylenesilacyclobutane (**1**) had been studied extensively by our group.<sup>1</sup> Silacyclobutane **1** was found to undergo a 1,2-silyl shift to a carbene, which then inserted into a C-H bond, giving silacyclopentenes **2** and **3** (major). This was surprising considering that this sort of olefin isomerization had previously only been observed in highly strained bridgehead olefins<sup>2-5</sup> or in a molecule with significant ring strain.<sup>6,7</sup> Also, this rearrangement was different than the mechanism of decomposition for the 1,1-dimethylsilacyclobutene, which fragmented to silene and ethylene.<sup>8</sup> Kinetic experiments were performed and the Arrhenius parameters were reported ( $\log A = 12.48$ ,  $E_{act} = 54.09$  kcal/mol) for the olefin to carbene isomerization. Deuterium labeling experiments showed that carbon-carbon homolytic cleavage was actually

occurring at temperatures below that required for 1,2-silyl rearrangement ( $\log A = 13.56$ ,  $E_{\text{act}} = 50.85$  kcal/mol). However, the diradical thus formed closed back to starting material rather than fragment to silene and allene (Scheme 1).

About the time this work was being completed, the first example of a methylenesilacyclobutene **4** appeared in the literature, synthesized through zirconocene mediated coupling by Takahashi and coworkers.<sup>9</sup>

Scheme 1. 1,2-Silyl shift of 1,1-dimethyl-2-methylenesilacyclobutane (**1**).

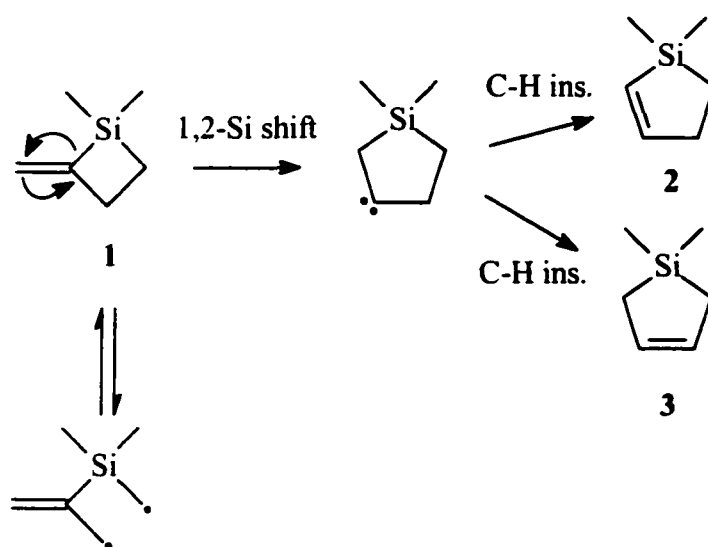

It was apparent that methylenesilacyclobutene **4** was an interesting molecule that could provide another example of the thermal rearrangement of an olefin to a carbene previously examined in our group for 1,1-dimethyl-2-methylenesilacyclobutane (**1**).<sup>1</sup> The possible rearrangement is shown in Scheme 2. If the 1,2-silyl shift occurs, the carbene formed would most likely insert into the  $\beta$  C-H bond giving the 2,5-diphenylsilole **5** ( $R = \text{Ph}$ ).

In addition to olefin isomerization, there was the possibility that electrocyclic ring opening, similar to that observed for the parent silacyclobutene,<sup>10</sup> would provide an allene containing silabutadiene **6** as an intermediate (Scheme 3) leading to unanticipated products.

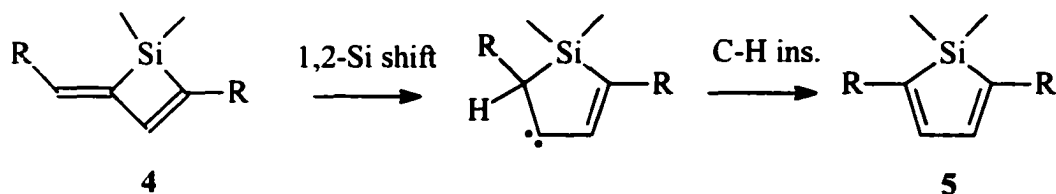
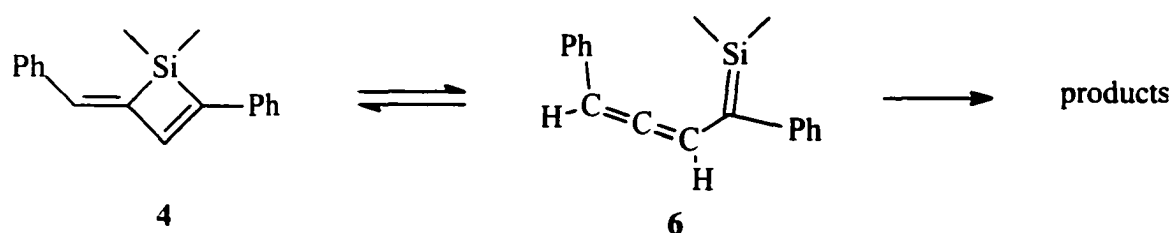

Scheme 2. Possible thermal rearrangement of methylenesilacyclobutene **4**.Scheme 3. Possible siladiene formation from methylenesilacyclobutene **4**.

With these things in mind, the study of the thermal and photolytic properties of **4** was undertaken. In addition this work would serve as a stalking horse to the study of **7** presumably available through the synthetic route of Takahashi. In addition to being the first germacyclobutene reported, **7** would also provide the opportunity to study the thermal isomerization of a methylenegermacyclobutene.

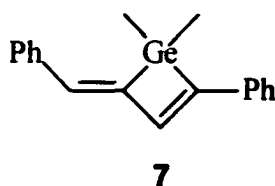

Diphenylmethylenesilacyclobutane **4** was first reported by Takahashi and coworkers<sup>9</sup> during the investigation of zirconocene mediated coupling reactions of acetylenes. They found that bisalkynyl silanes underwent intramolecular coupling when reacted with the zirconocene-ethylene complex, giving a zirconium fused ring intermediate which locks the regiochemistry of the exocyclic methylene in the *cis* conformation. The zirconium residue can be removed by acidic work-up giving **4** (Scheme 4), or reacted with iodine to give a 3,5-diiodo compound.

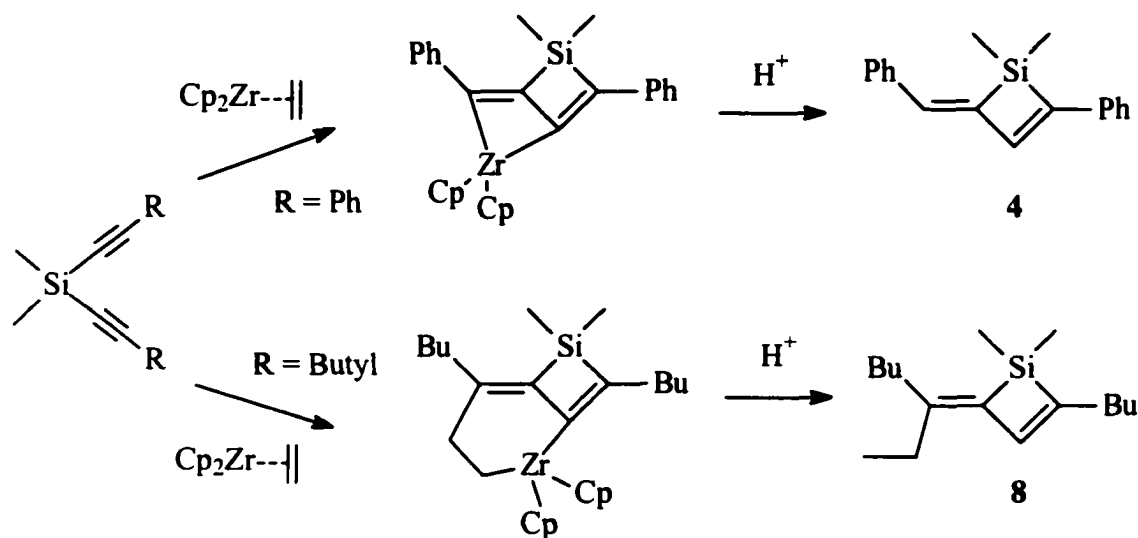
Scheme 4. Synthesis of methylenesilacyclobutenes **4** and **8**.<sup>9</sup>

When R= butyl (or any alkyl) the ethylene of the zirconocene complex becomes incorporated into the zirconocyclic intermediate rather than being eliminated upon addition across the acetylene. The result is that upon work-up an ethyl substituent remains on the exocyclic methylene, giving **8**.

There have been no reported studies on the photolytic or thermal behavior of **4**, though some of its chemical properties have been studied by Takahashi and coworkers<sup>11</sup>(Scheme 5). Takahashi found that disubstituted butadienes could be formed through hydrolysis of the methylenesilacyclobutene with aqueous CuCl. For example, the reaction of **4** with 1 equivalent CuCl in water gave the silanol **10**, presumably through a regioselective Si-C cleavage to form a vinyl copper species followed by hydrolysis. The silanol **10** can be desilylated with concentrated HCl to give (*E,E*)-diphenyl-1,3-butadiene **11**. Palladium coupling reactions with phenyl iodide seem to support the intermediacy of the proposed copper species, as phenylation at the 3 position, giving **9**, is observed using Pd<sup>(0)</sup> C-C coupling conditions. This aqueous copper chloride mediated ring cleavage has not been reported for the parent silacyclobutene, which is susceptible to a wide variety of electrophilic and nucleophilic cleavage reactions, including those initiated by alcohols and water.<sup>12</sup>

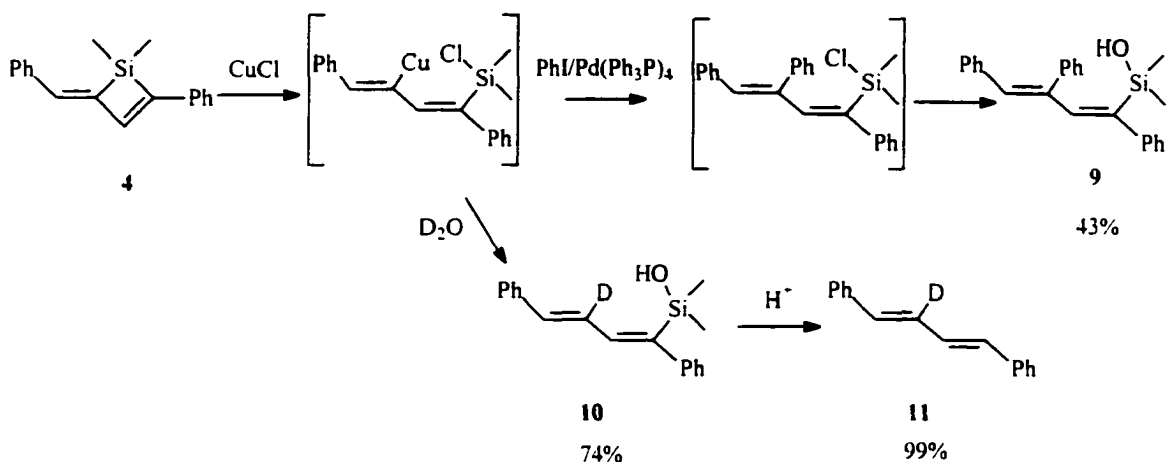
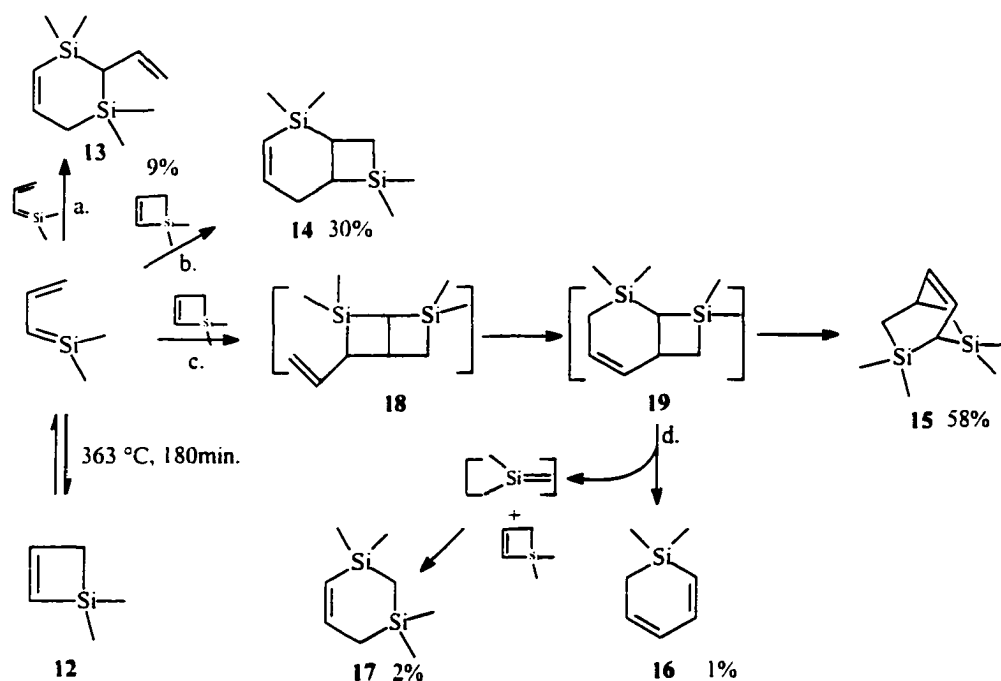
Scheme 5. Chemical reactivity of methylenesilacyclobutene **4**.<sup>11</sup>Scheme 6. 1,1-Dimethylsilacyclobutene (**12**) thermal rearrangement.<sup>10</sup>

Since **4** is a silacyclobutene and may undergo reactions and photolytic and thermal behavior similar to that of the unsubstituted compound, an exploration of the photolytic and thermal properties of the parent compound 1,1-dimethylsilacyclobutene (**12**) presented in the literature is relevant here. Conlin studied the pyrolysis

of **12** in a static vessel, (Scheme 6),<sup>10</sup> and found that during thermolysis, an equilibrium with the ring opened siladiene was established. Various dimerizations of the siladiene with starting material and itself then gave five different products.

The photochemistry of **12** has been examined in some detail. As in the thermolysis, the photochemical behavior is thought to involve a siladiene intermediate. In a trapping study, 1,1-dimethyl-2-phenylsilacyclobutene (**20**) was found to produce three adducts in methanol (Scheme 7).<sup>13</sup>

Scheme 7. Photolysis of phenylsilacyclobutene **20**.<sup>13</sup>

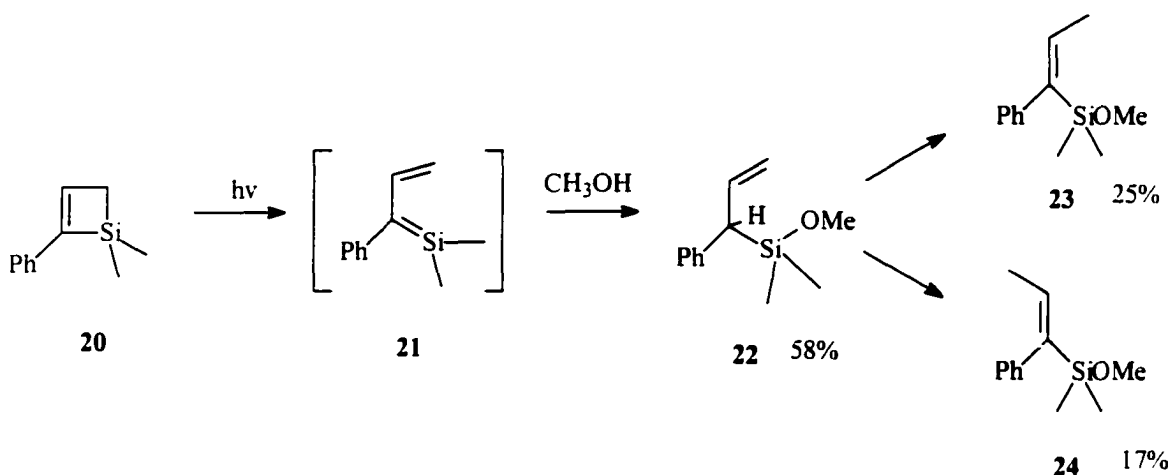

Photolytic ring opening to a siladiene followed by addition of methanol across the Si=C bond gave the allylic silane **22**. The vinylic regioisomers, **23** and **24**, were determined to have derived from photoisomerization of **22**. Labeling studies supported this, as the trapping with MeOD showed deuterium incorporation only at the benzylic position of **22**.

However, later studies<sup>14</sup> of **12** indicated a more complex mechanism was operative (Scheme 8). Stienmetz and coworkers examined all possible photoreactivities of **12**, namely 1) electrocyclic ( $\pi, \pi^*$ ) ring opening shown above, 2) carbene rearrangement mechanisms ( $\pi, 3s$ ), and 3) a proto-desilylation mechanism (protonation on C2 to form a carbocation, followed by ring opening to an allylic alkoxy silane).

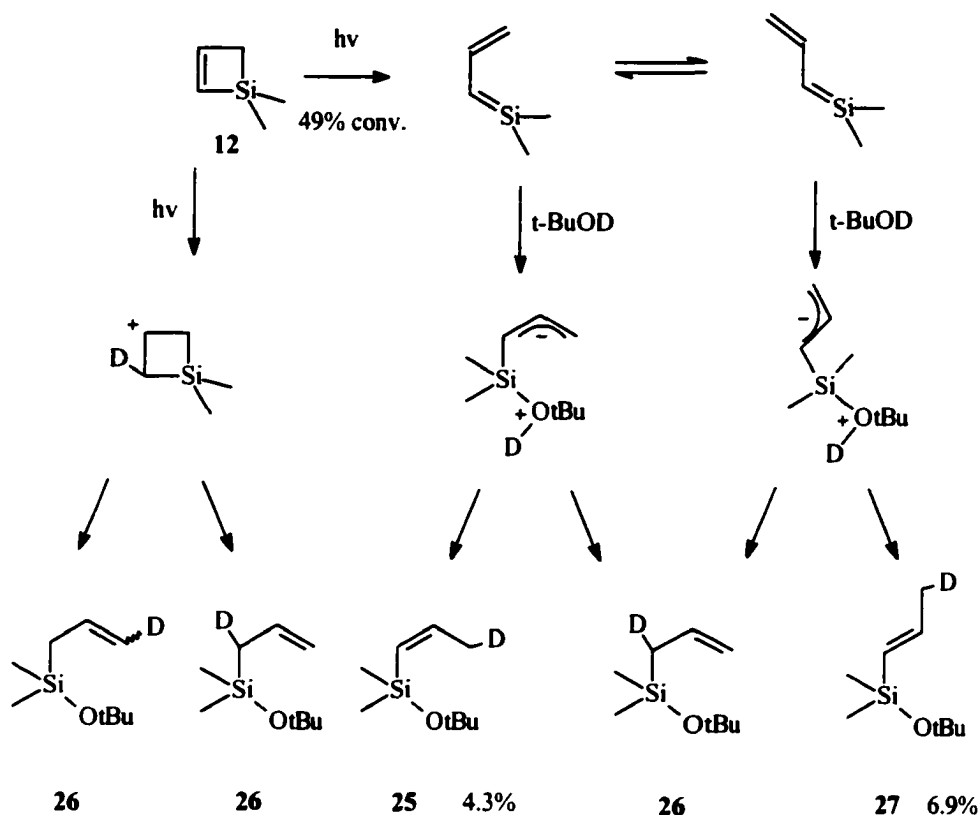
Scheme 8. Mechanism of silacyclobutene photolysis.<sup>14</sup>

**26** total yield 29%. D labeling 93.5:6.5 C1:C3

Steinmetz found through careful labeling studies that 87% of the products were derived through the electrocyclic mechanism and 13% were from the proto-desilylation mechanism. In the modified mechanism, the initial *cis*-siladiene isomerizes into a *transoid* form before trapping by *t*-butyl alcohol. This was supported by the observation of different product ratios with varying concentrations of alcohol and varying temperature of the reaction. The zwitterionic intermediates account for the *cis-trans* isomeric products (**25**, **27**). All the products were found to be primary products.

Surprisingly, the parent silacyclobutene, **12** (and also **20**), was found to react with methanol in the absence of light.

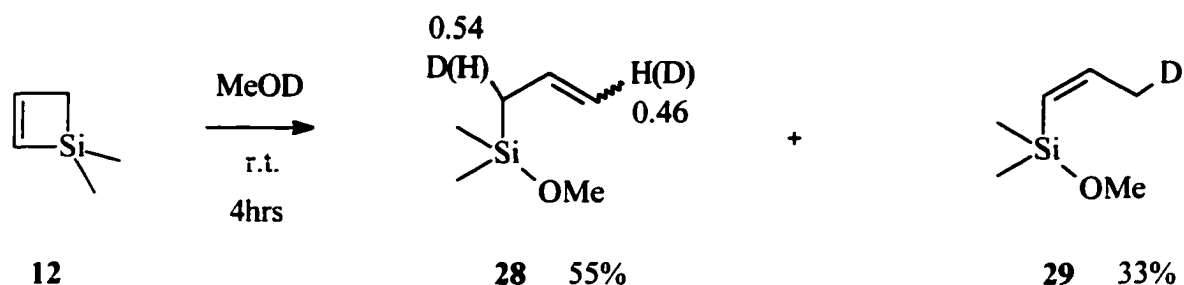
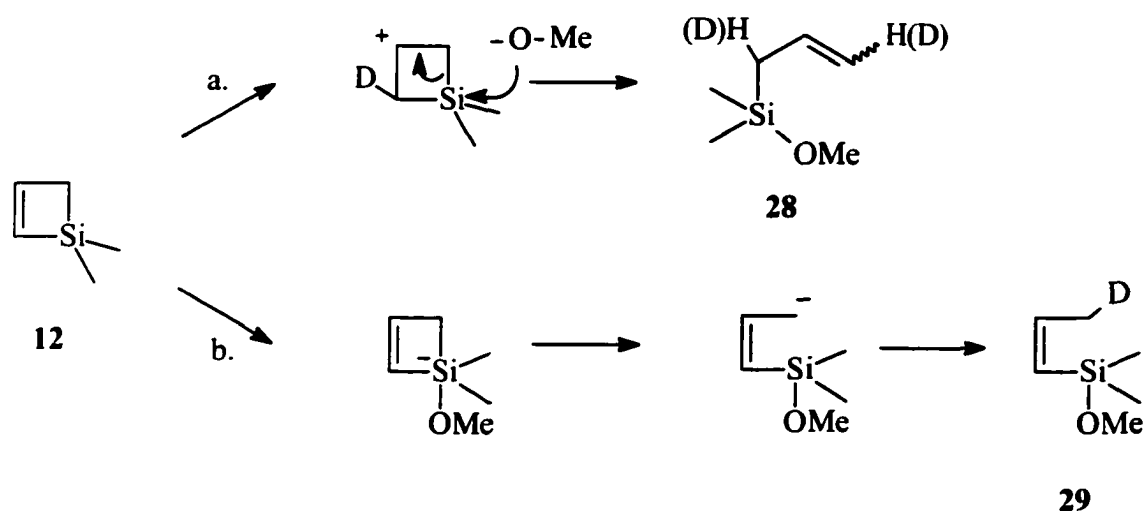
Scheme 9. Reaction of silacyclobutene with methanol in the dark.<sup>14</sup>Scheme 10. Mechanism of reaction of **12** with methanol in the dark.<sup>14</sup>

Two products were obtained (Scheme 9), **28** and **29**. Deuterium incorporation in **28** was distributed at the C<sub>1</sub> (0.54) and C<sub>3</sub> (0.46) positions and in **29** only at C<sub>3</sub>. This process is thought to occur by the mechanism shown in Scheme 10.

In path a, protonation followed by ring cleavage gives **28** with deuterium scrambling; or path b, where nucleophilic attack by methoxide anion gives a pentavalent silicon species which then undergoes ring cleavage, and subsequent protonolysis yielding **29**. It was found that the presence of trace amounts of acid results in a 4.5:1 ratio of path a to path b, with a significant rate decrease. The

addition of catalytic amounts of sodium methoxide leaves the product ratio unchanged, but with a 50-fold rate increase. Therefore, the presence of trace amounts of acidic impurities in methanol probably gives rise to path a, while path b arises from methoxide possibly created through self protonolysis.

## Results and Discussion

Methylenesilacyclobutene **4** was synthesized according to the literature in good yield.<sup>9</sup> Compound **4** was purified by recrystallization followed by flash chromatography in order to insure complete removal of any zirconium-containing impurities. The product was a white crystalline material, water stable, and air stable when kept in the dark.

Initial chemical reactivity experiments were conducted by simply stirring **4** with methanol or ethanol. The reaction appears to go slowly or not at all without a trace of base. However, complete reaction was observed in light or dark at room temperature, provided a basic catalyst such as sodium alkoxides, were used. The products were obtained in quantitative yield as shown in Scheme 11, and were air and water stable.

The products were the result of a formal addition of the alcohol across the Si-C<sub>4</sub> bond, giving (*E,Z*)-1,4-diphenyl-1-(methoxydimethylsilyl)-1,3-butadiene **32** and (*E,Z*)-1,4-diphenyl-1-(ethoxydimethylsilyl)-1,3-butadiene **31** respectively with methanol and ethanol. The product **32D**, (*Z,E*)-1,4-diphenyl-1-(methoxy-d<sub>3</sub>-dimethylsilyl)-1,3-butadiene-3d, was produced from quenching with methanol-d<sub>4</sub>. Trace amounts of a minor product from addition across the Si-C<sub>1</sub> bond were sometimes observed, as shown in Scheme 14. These ring opening reactions may proceed through a mechanism (Scheme 12) similar to that suggested by Steinmetz for **12** (Scheme 10).

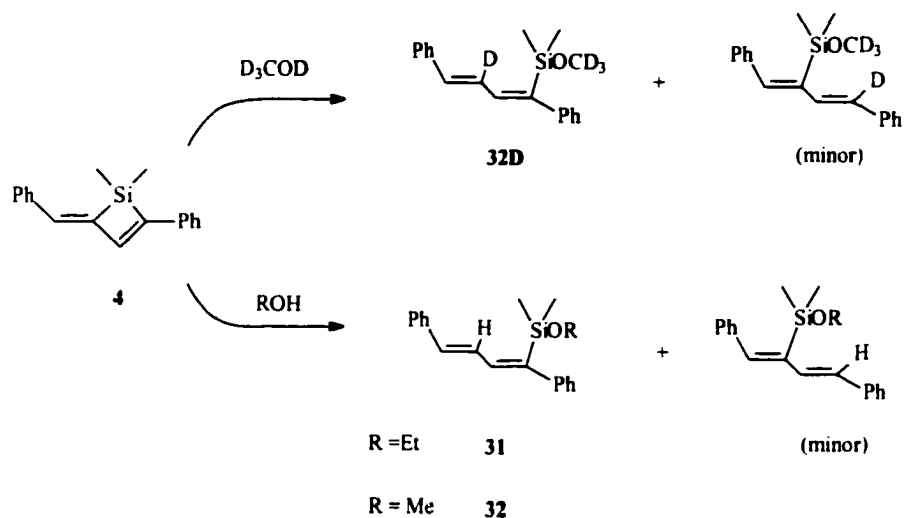
Scheme 11. Reaction of methylenesilacyclobutene **4** with alcohols.

Paths a and b are analogous to those discussed for **12**; in path a, protonation at C<sub>3</sub> provides a benzyl carbocation on C<sub>4</sub>. Addition of the alcohol then produces ring opening. Of course such a mechanism suggests a loss of regiochemistry around the exocyclic methylene, but does not require it. In path b, the formation of a pentavalent silicon by attack of methoxide anion is followed by ring opening to afford the product.

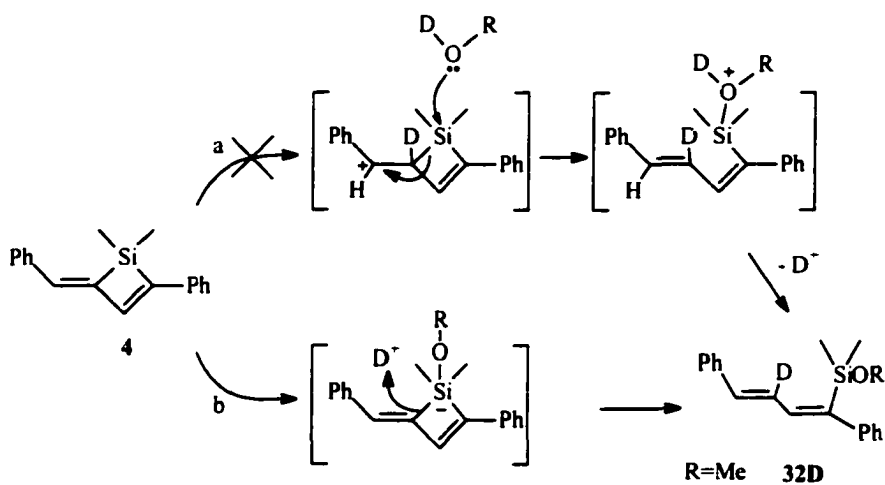
Scheme 12. Mechanism of ring opening of methylenesilacyclobutene **4** with alcohols.



The reaction was studied qualitatively by adding either catalytic amounts of sodium ethoxide or concentrated sulfuric acid to a stirring solution of **4** in ethanol. The alkoxide-catalyzed reaction was accelerated greatly, while the acid-catalyzed reaction not only showed no rate increase but produced only traces of new products which were not further examined. These results support path b as the most likely mechanism of the two for the reaction of **4** with alcohols.

Photolysis of a degassed hexane solution of **4** at 350 nm for 2.5 hours gave an approximately 1:1 ratio of a what was eventually determined to be photoisomer **33** and the starting material **4**.

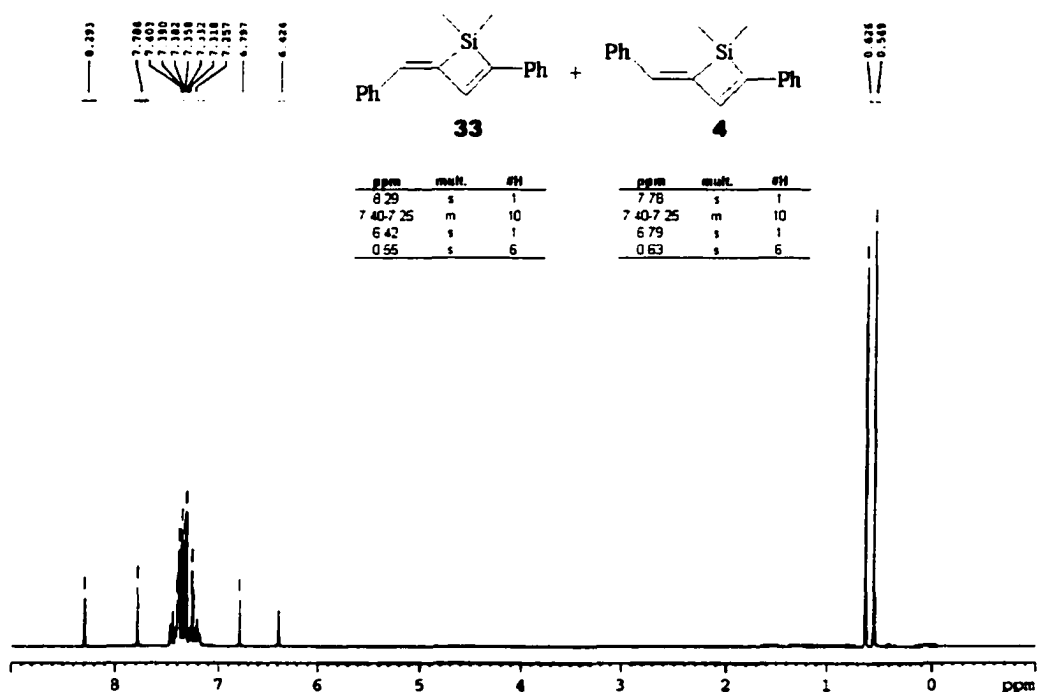

Figure 1.  $^1\text{H}$  NMR spectrum of the products of photolysis of methylenesilacyclobutene **4**.

The isomer appeared to be air and water stable. A variety of purification techniques were employed with no success.

The photoisomer **33** did not appear to survive column chromatography or preparative TLC, with the starting material **4** being the only isolable compound from

the photolysis mixture. Of course, the survival of **4** under purification conditions where photoisomer **33** decomposes is quite surprising given their structural similarities. Fractional recrystallization only succeeded in crystallizing out **4**, still leaving a mixture that refused to crystallize further. However, the NMR spectroscopy of **33** could be obtained by subtraction. The  $^1\text{H}$  NMR spectrum of the mixture (Figure 1) shows new peaks (singlets) at 8.3, 6.42, and 0.54ppm in a 1:1:6 ratio.

The data precludes the desired silole, but is consistent with (*Z*)-1,1-dimethyl-2-(phenylmethylene)silacyclobutene **33**, the product from isomerization of the exocyclic double bond (shown in Scheme 13).

Scheme 13. Photoisomerization of methylenesilacyclobutene **4**.

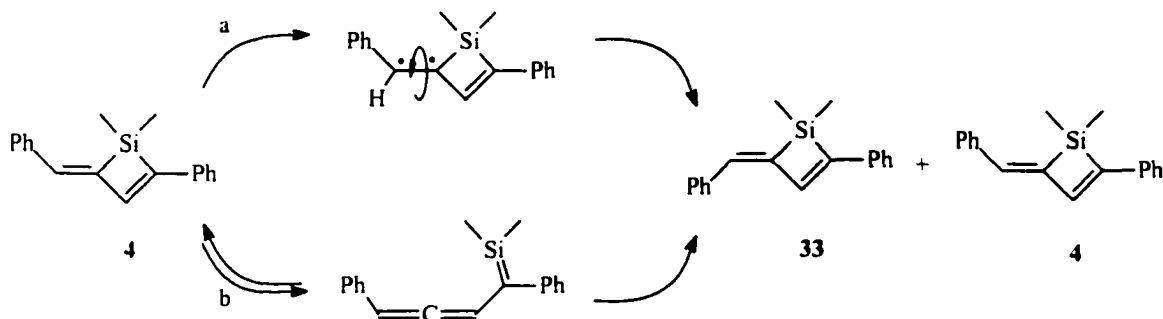

It appears that a photo-stationary state is reached where the ratio of isomers is 1:1 since longer photolysis times do not affect the yield or the product ratio. The isomerization itself does not require the intermediacy of the siladiene in path b although a corotatory electrocyclic ring closure of the siladiene would presumably give a mixture of **33** and **4**. A simple alkene isomerization is consistent with the results, where the 1,2-biradical allows rotation, then reforms as is path a, also giving a mixture of both isomers. Trapping experiments with alcohols were carried out in an attempt to show the presence of a Si=C bond. The trapped siladiene was not observed after photolysis at 350 nm in methanol for 45 minutes. Note that the dark reaction of **4** with alcohols is very slow (when uncatalyzed) and does not occur significantly in the time frame relevant to these experiments. However, two isomeric

products were formed in the photolysis; (*E,Z*)-1,4-diphenyl-1-(methoxydimethylsilyl)-1,3-butadiene **32** (12%) and (*Z,Z*)-1,4-diphenyl-1-(methoxydimethylsilyl)-1,3-butadiene **34** (88%). The minor isomer **32** is the same as that observed from simple methanolic quenching of **4**, but must be the result of a reaction of a photoexcited state, due to the rapidity of the reaction. The major product turned out to be a secondary photoproduct.

Scheme 14. Photoisomerization of 1,4-diphenyl-1,3-butadienes **32** and **31**.

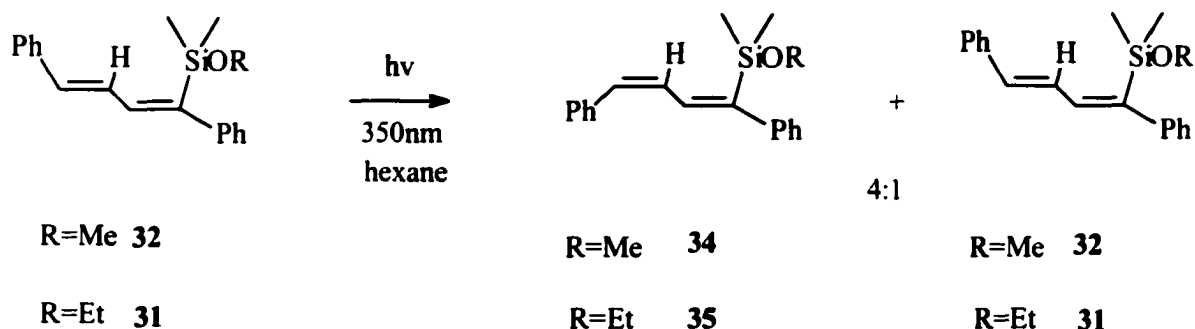

Later experiments (Scheme 14) showed that **34** could be readily produced from **32** under the same reaction conditions. The reaction provided the same ratio of **34:32** as the photolysis of the **4** in methanol.

Apparently, ring cleavage by the alcohol is the primary reaction, followed by isomerization to the (*Z,Z*) diene **32**. This photoisomerization is analogous to that of (*E,E*)-1,4-diphenyl-1,3-butadiene to (*Z,E*)-1,4-diphenyl-1,3-butadiene (Scheme 15).<sup>15</sup>

Scheme 15. Photoisomerization of 1,4-diphenyl-1,3-butadienes.

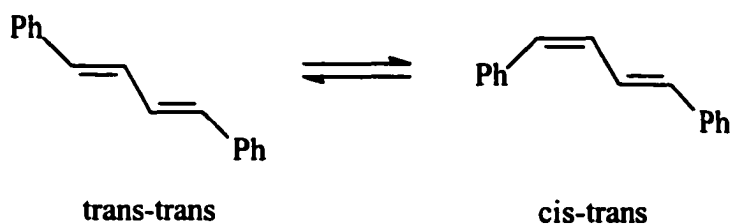

The *trans-trans* form of 1,4-diphenyl-1,3-butadiene isomerizes to the *cis-trans* form under direct irradiation at 325 nm in cyclohexane. The photoequilibrium state was reached at 0.19 mol fraction of the *trans-trans* form and 0.81 mol fraction of the *cis-trans* form, which is very similar to the ratio produced in our case.

Since **4** is known to react with alcohols under certain conditions and the proposed photoisomer **33** is structurally very similar, some additional structural information could be obtained by the reaction of the photolysis mixture with an alcohol. Unfortunately, the resulting products **36** and **31** (Scheme 16), though produced cleanly as expected, could not be separated.

Scheme 16. Derivatization of methylenesilacyclobutenes **4** and **33** with ethanol.

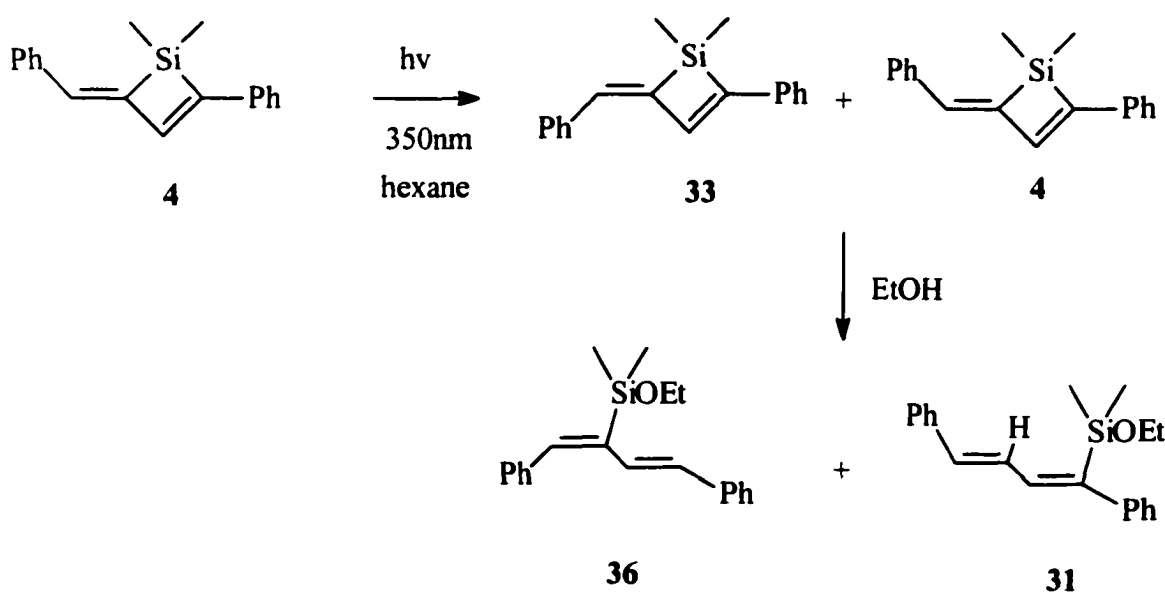

The identification of the newly formed isomer **36** was problematic since the  $^1\text{H}$  NMR spectrum shows only two new signals in the vinyl region, which in this case is very close to the phenyl region. It seemed likely that some vinyl signals in this isomer (and perhaps others) were being obscured in the phenyl region, so a deuterium labeled precursor **38** was synthesized (Scheme 17). Thus, the likelihood of misinterpretation of the data was reduced. The labeling was accomplished by preparing bis(phenyl- $d_5$ -ethynyl)dimethylsilane from the palladium catalyzed

coupling of phenyl-d<sub>5</sub> iodide and bis(ethynyl)silane. The ring closure was accomplished in good yield using the previously described route. The deuterium labeled compound was then photolyzed. This provided a mixture of (*E*)-1,1-dimethyl-2-(phenyl-d<sub>5</sub>)-4-(phenyl-d<sub>5</sub>-methylene)silacyclobut-2-ene **39** in a 1:1 ratio with the starting material **38**. Quenching with ethanol then provided **40** and **41** respectively in accordance with the previously devised method.

Scheme 17. Preparation of deuterium labeled methylenesilacyclobutene **38**.

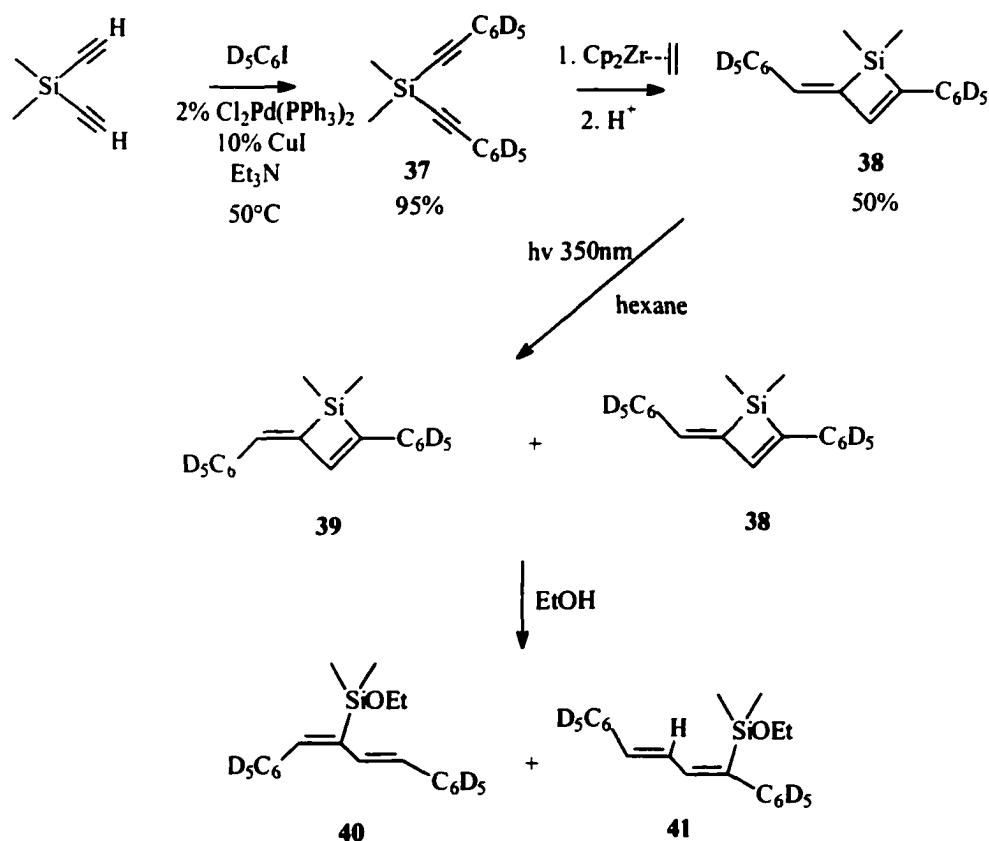

Analysis of the <sup>1</sup>H NMR spectrum of the mixture of **39** and **38** revealed no new signals in the now unobstructed phenyl region. However, as expected, new information was obtained for the isomer **40**. In Figure 2, the <sup>1</sup>H NMR spectrum of the mixture of deuterium labeled compounds **41** and **40** are shown. The labeling allows the third vinyl proton of **40** (a doublet of doublets (*J* = 16.5, 09 Hz)) to be

seen. In order to confirm that the new signal did indeed belong to **40**, the ethanol quenching product of **38** was prepared and characterized; no new peaks were observed in the phenyl region, therefore the new signal was assigned correctly. The data is consistent with the structure shown. It appears that quenching with ethanol occurs by addition across the Si-C<sub>4</sub> bond for the (*E*) isomer (**39**, **33**) and across the Si-C<sub>1</sub> bond for the (*Z*) isomer (**38**, **4**).

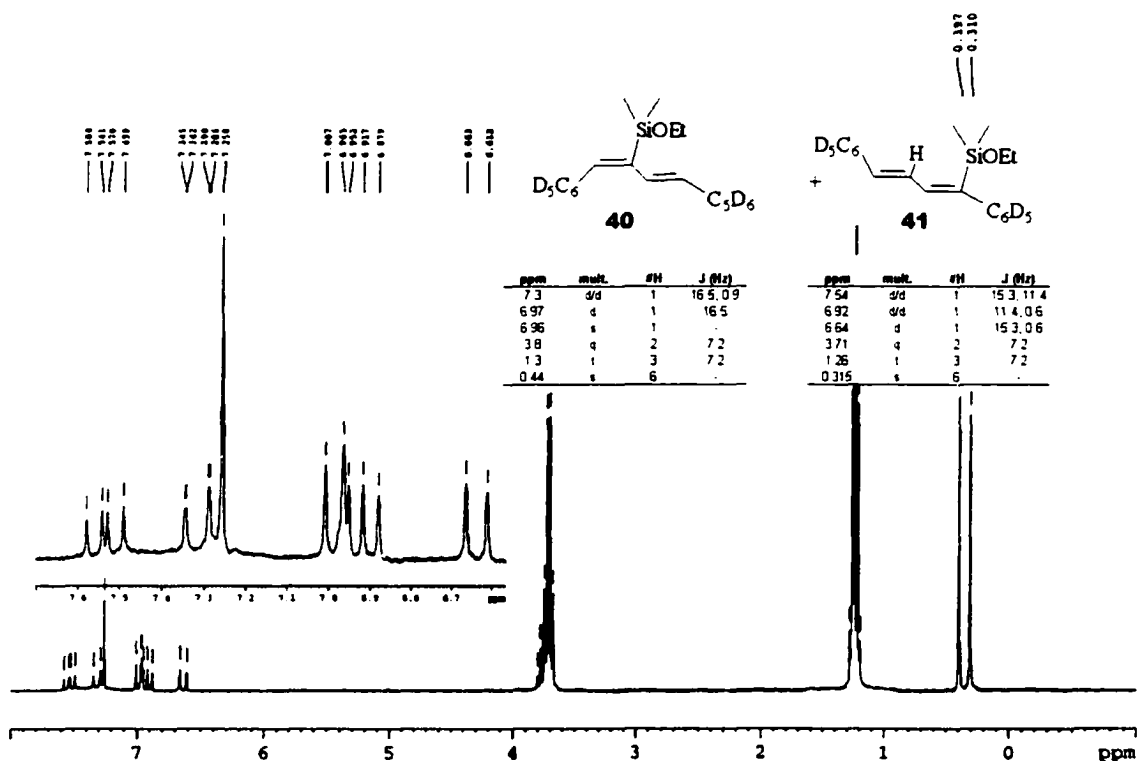
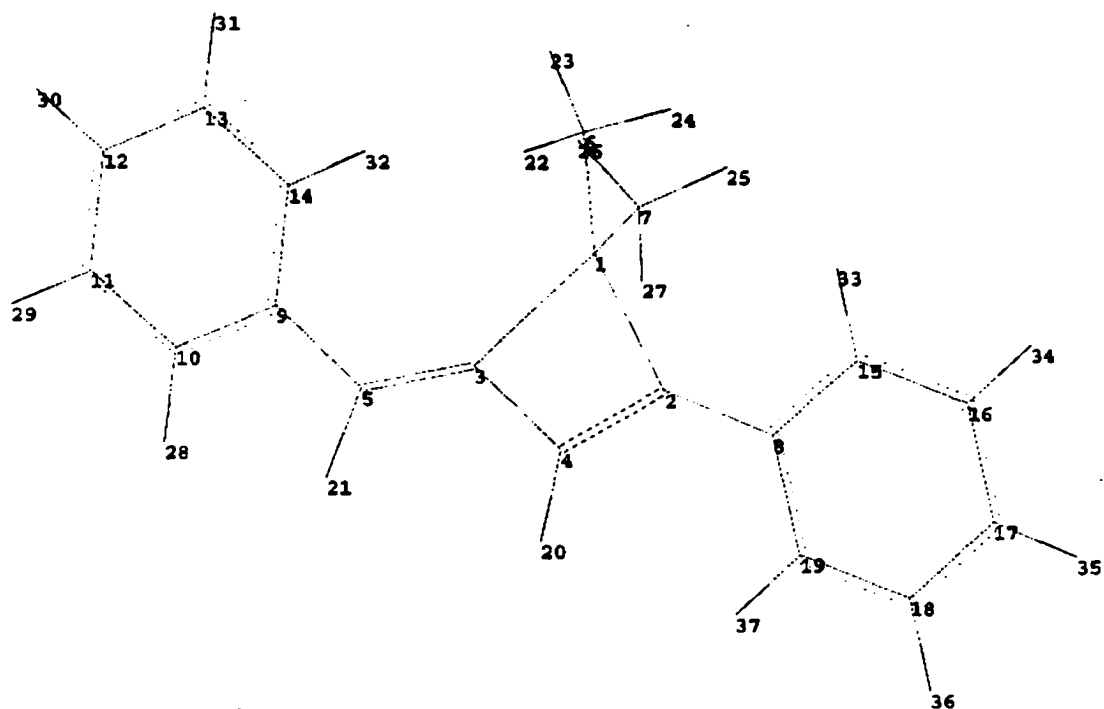

Figure 2. <sup>1</sup>H NMR spectrum of 1,4-diphenyl-1,3-butadiene **41/40** mixture.

The regioselectivity of the quenching of the photoisomers could be controlled by steric factors, since it appears that the *trans*-type conformation of **33** would allow less hindered approach to the Si-C<sub>1</sub> bond. Molecular modeling (AM1) was carried out to try to gain a better understanding of this regioselectivity. Calculations were carried out from a variety of initial states which all converged to a similar geometry. These calculated structures are shown in Figure 3 and Figure 4.



## Bond Length

Atom	bond L
1-3	1.880
1-2	1.894
1-7	1.806
1-6	1.808
2-4	1.361
2-8	1.438
4-3	1.474
3-5	1.333
5-9	1.454

## Bond Angles

atom	atom	atom	Angle
<b>ring</b>			
3	1	2	73.83
1	2	4	91.43
1	3	4	88.59
3	4	2	106.14
<b>endo</b>			
20	4	2	129.49
3	4	20	124.37
1	2	8	140.72
4	2	8	127.83
<b>exo</b>			
9	5	21	114.15
21	5	3	119.71
9	5	3	126.08
5	3	1	145.62
5	3	4	125.78
<b>si</b>			
2	1	7	116.40
7	1	6	111.85
3	1	6	116.69

## Torsion Angles

atom	atom	atom	atom	Angle
3	5	9	14	25.64
4	2	8	19	-28.29

Figure 3. Calculated Geometry of methylenesilacyclobutene 4.

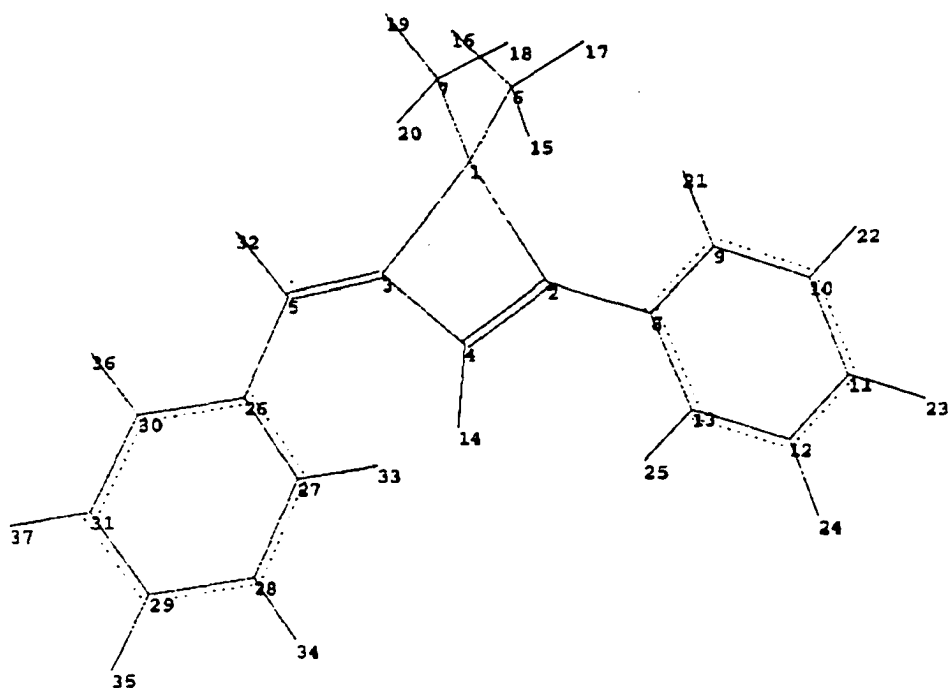

## Bond Length

Atom	bond L
1-3	1.876
1-2	1.894
1-7	1.807
1-6	1.806
2-4	1.362
2-8	1.438
4-3	1.472
3-5	1.331
5-26	1.457

## Bond Angles

atom	atom	atom	Angle
<u>ring</u>			
3	1	2	73.82
1	2	4	91.38
1	3	4	88.77
3	4	2	106.03
<u>endo</u>			
14	4	2	129.40
3	4	14	124.55
1	2	8	140.77
4	2	8	127.85
<u>exo</u>			
26	5	32	113.57
32	5	3	119.78
26	5	3	126.65
5	3	1	141.21
5	3	4	130.02
<u>si</u>			
2	1	7	116.42
7	1	6	111.78
3	1	6	116.50

## Torsion Angles

atom	atom	atom	atom	Angle
3	5	26	27	-41.05
4	2	8	13	26.35

Figure 4. Calculated geometry of methylenesilacyclobutene 33.



A closer look at the data does not reveal any explanation more profound than steric hindrance. The data shows that the bond angles around the ring are quite distorted from trigonal, especially around the  $sp^2$  ring carbons, indicating the presence of strain. The calculated bond angles are nearly the same for both isomers, except for the angles around atom 3. In **33**, the angle 1-3-5 is  $141^\circ$  while in **4** it is  $145^\circ$ . The wider angle is probably caused by steric repulsion between the phenyl group and the silicon methyl groups. Based on the geometries it is likely that the addition across the 1-3 bond would be favored for **4**, since this would relieve the distorted geometry at that site. However, in **33** the angles are roughly the same around both atoms 2 and 3. In this case attack is across the 1-2 bond.

Another trapping experiment was performed in order to provide evidence of the presence of a siladiene intermediate. Acetone has been used for this purpose in previous work.<sup>16-13</sup> A solution of **4** (0.01 M) and acetone (1.36 M) in 30 mL of hexane was photolyzed at 350 nm for 2 hours. Conversion was complete to the trapped product **44** (Scheme 18).

Scheme 18. Photolysis of methylenesilacyclobutene **4** in the presence of acetone.

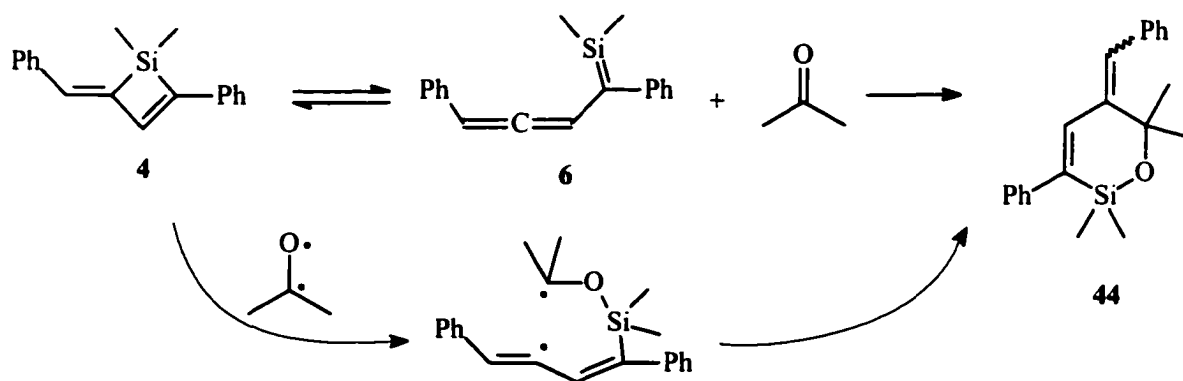

One could argue that some slight absorbance of acetone to create a triplet carbonyl that reacts with **4** would give the same product as a 4+2 cycloaddition of acetone to the intermediate siladiene. However, the extinction coefficients at 350 nm of **4** ( $\epsilon = 34566$ ) and acetone ( $\epsilon = 0.01703$ ) reveal that it is unlikely for the

observed trapping to be the result of the triplet carbonyl. Even if one considers the spectral distribution of the light source, the extinction coefficient of acetone ( $\lambda_{\max}$  278 nm,  $\epsilon = 14.7$ ) is very small even at its  $\lambda_{\max}$  in the pertinent region.

The thermolysis of **4** was examined under a variety of conditions. Table 1 shows some examples of the results obtained. In all cases the thermolysis resulted in isomerization of the exocyclic methylene, giving **33** as the product. The reactions were relatively clean except at elevated temperatures (300 °C for sealed tube reactions, 650 °C for flow pyrolysis) where decomposition to a black insoluble material occurred.

Scheme 19. Thermolysis of methylenesilacyclobutene **4**.

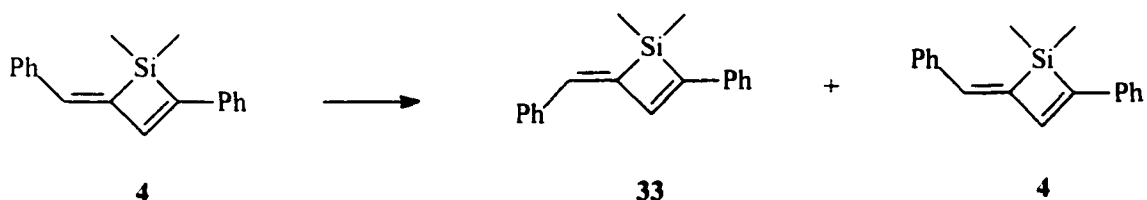

Table 1. Methylenesilacyclobutene **4** thermolysis conditions and results.

Temperature (°C)	Time (hrs)	Type	Ratio of Si-Me signals in $^1\text{H}$ NMR(4:33)
200	24	sealed tube, phenylether	8.4:1
200	24	sealed tube, neat	16:1
250	4	sealed tube, neat	1:1
300	24	sealed tube, neat	decomposition
600	n.a.	flow, hexane	3.2:1
650	n.a.	flow, hexane	2:1

The product ratios were obtained by a comparison of the  $^1\text{H}$  NMR signals of the silicon methyls of **4** and **33**. Silacyclobutene **4** was found to be quite thermally stable, requiring high temperatures for isomerization. The first attempts at pyrolysis in a flow system required a temperature of 600 °C to give a (roughly) 23% conversion to the regioisomer **33**, while reactions in a sealed tube at 200 °C for 24 hours only provided a conversion to **33** of 6%. The best conditions were found to be neat at 250 °C for 4 hours in a sealed tube, providing 50% conversion. Higher temperatures resulted mainly in decomposition.

Synthesis of the germanium analog **7** was carried out according to Scheme 20. The bis(phenylethynyl)germane was obtained in 82% yield. Next the zirconocene mediated intramolecular cyclization was carried out according to the method of Takahashi.<sup>9</sup> The coupling resulted in the formation of two products in a roughly one to one ratio.

Scheme 20. Synthesis of methylenegermacyclobutene **7**.

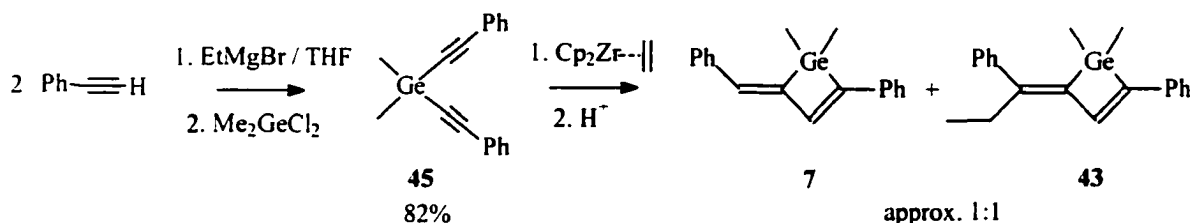

The expected product **7** was observed as well as **43**, a type of product usually observed when an alkyl substituted bis(alkynyl)silane is used. As mentioned previously, when phenyl or *t*-butyl substituted bis(alkynyl)silanes are employed, the unsubstituted product is observed. When an alkyl substituted bis(alkynyl)silane is used, the product has an additional ethyl group on the exocyclic methylene. This is probably a consequence of the mechanism, outlined in Scheme 21.<sup>9</sup> The proposed mechanism suggests the products are derived from intermediates created by different modes of addition of zirconocene species to the alkyne during the initial addition. Elimination of ethylene from the adduct gives a zirconocyclopropene, while

insertion of ethylene in the adduct gives a zirconocyclopentene. Both adducts undergo rearrangement, followed by removal of zirconium through hydrolysis to give the final product. The different additions are possibly a result of steric effects, since the large groups ( $R = \text{phenyl, } t\text{-butyl}$ ) add to give the zirconocyclopropene, while less bulky groups result in addition to form the zirconocyclopentene. In the case of germanium the longer Ge-C bond length may reduce steric hindrance enough to allow both modes of addition to occur with equal facility.

Scheme 21. Proposed mechanism of cyclization.

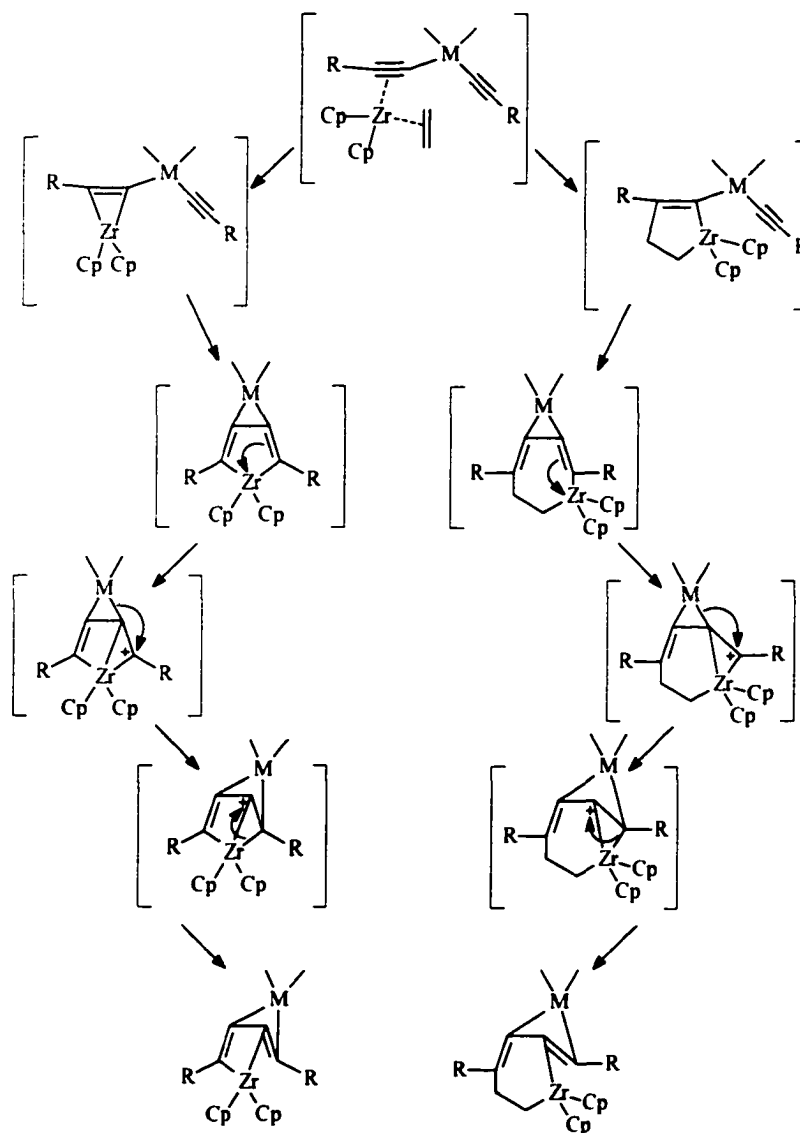

The products **7** and **43** were identified by GC-MS and  $^1\text{H}$  NMR spectra of the mixture. Unfortunately, all efforts to isolate **7** and **43** were unsuccessful: attempts at fractional crystallization failed, resulting only in co-crystallization. The mixture was also subjected to chromatography in an attempt to isolate **7** but these efforts were similarly unsuccessful.

### Conclusion

The photolytic properties of the novel diphenylsilacyclobutene **4** have been examined in this work. Under photolytic conditions, **4** only isomerizes to form the regioisomer **33**. Eventually a photo-stationary state is reached where the ratio of the two isomers is approximately 1:1. The cleavage of the ring system of **4** can be accomplished by alcohols in the presence of base, giving diphenylbutadienes as shown in Scheme 22. The ring cleavage is regioselective, probably due to steric hindrance, as suggested by the calculated (AM1) structures. Therefore, in isomer **4**, the  $\text{Si}_1\text{-C}_2$  bond is broken, while in isomer **33**, the  $\text{Si}_1\text{-C}_4$  bond is broken.

Scheme 22. Reactions of methylenesilacyclobutene **4**.

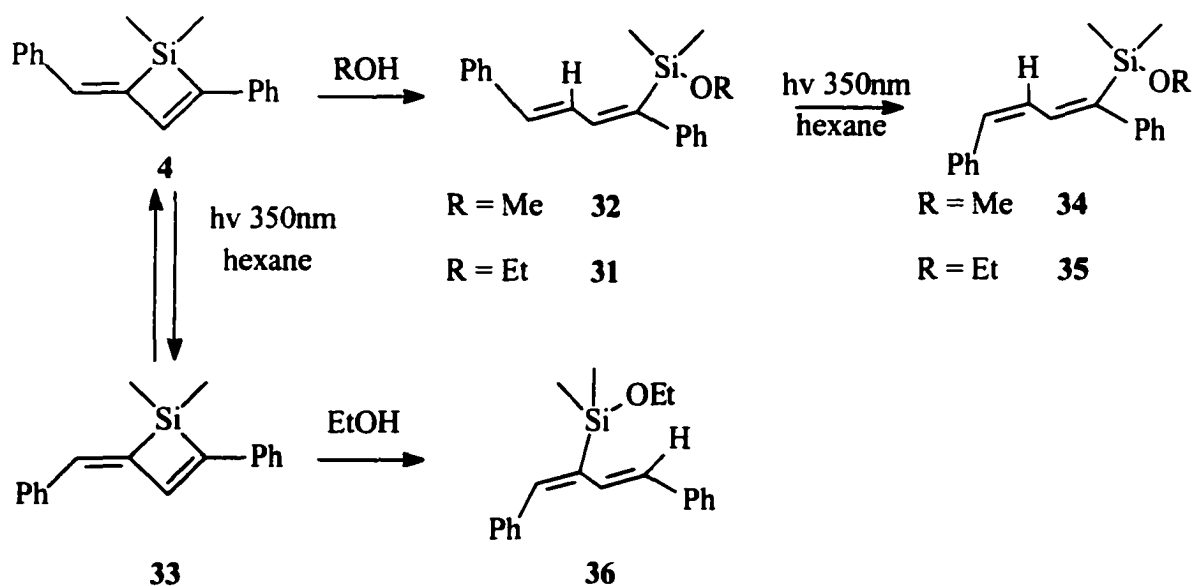

While the isolation of some of the products could not be accomplished, a careful examination of the available data supports the proposed products. In addition, the synthesis of deuterium labeled analogs allowed clean  $^1\text{H}$  NMR spectra to be taken of several key compounds where important structural information was likely to have been concealed by other signals. The thermal behavior of **4** was studied. The primary thermal reaction appears to be isomerization to the regioisomer **33**, which is the same isomer produced during the photolytic reaction.

### Experimental Section

$^1\text{H}$  and  $^{13}\text{C}$  NMR spectra were acquired on a Varian VXR-300 spectrometer. Chemical shifts are reported in parts per million with the indicated solvent as standard. Proton splitting is reported using standard abbreviations. Routine infrared spectra are reported in wave numbers ( $\text{cm}^{-1}$ ) and were obtained on a Bio-Rad Digilab FTS-7 spectrometer from a neat sample (except where noted). Other IR spectra were obtained on a Hewlett Packard GC-IR-MS (GC: HP 5890, IR: HP 5965A, MSD: HP 5970). UV/Vis spectra were obtained using a Hewlett Packard 8452A diode array UV/Vis spectrometer. Mass spectra are reported as  $m/z$  (relative intensity) and were obtained on the previously described GC-MS-IR or a Hewlett Packard GC-MS (GC: HP 5890 series II, MSD: HP 5972). Exact masses were acquired on a Kratos MS 50 mass spectrometer. Quantitative gas chromatography was performed on a Hewlett Packard 5890 series II GC equipped with a flame ionization detector. Except where indicated a 30 m 0.25 mm i.d. capillary column with DB-5 stationary phase was utilized for all gas chromatography. The carrier gas used was helium.

THF and ether were distilled over sodium-benzophenone right before use. For rigorous drying, THF was subjected to a second distillation over lithium aluminum hydride before use. Other reagents were used as received (without further purification) from Aldrich, Fisher Chemical, or Gelest except where indicated.

Flow pyrolysis was carried out using a vertical 50 cm quartz tube (interior diameter of 15 mm) packed with quartz chips. The tube was heated by an oven controlled by a Digi-Sense temperature controller. Sealed tube pyrolysis were carried out by placing the sealed vessel in a perforated 80 mm steel tube wrapped with heating tape. Temperature was controlled by a Digi-sense temperature controller, with the thermocouple being placed inside the tube. Photolysis were carried out in a Rayonet photochemical apparatus.

**Bis(phenylethynyl)dimethylsilane (30).** This compound was made according to the literature.<sup>17</sup> A solution of dry THF (50 mL) and phenylacetylene (10.2 g, 11 mL, 100 mmol) was added to ethylmagnesium chloride (50 mL, 100 mmol, 2.0 M in THF) to maintain a gentle reflux. After addition the reaction mixture was refluxed for 1 h, then allowed to cool to room temperature. The reaction mixture was then cooled to  $-78\text{ }^{\circ}\text{C}$  in a dry ice/acetone bath, and a solution of dimethyldichlorosilane (6.45 g, 4.3 mL, 50 mmol) in THF (30 mL) was added by syringe. Upon completion of the addition, the reaction mixture was allowed to warm to room temperature and stir for 3 h. The reaction mixture was then quenched in sat. ammonium chloride (200 mL), and then extracted with ether (2 x 100 mL). The combined organic portion was washed with water (100 mL), then dried over magnesium sulfate. After solvent removal *in vacuo*, The product was recrystallized from hexane to give **30** (9.1 g, 35 mmol, 70%) as a white crystalline solid (m.p. 77-78  $^{\circ}\text{C}$ , lit. m.p. 78-79  $^{\circ}\text{C}$ <sup>17</sup>).  $^1\text{H}$  NMR ( $\text{CDCl}_3$ )  $\delta$  7.5(m, 4H, ArH), 7.32(m, 6H, ArH), 0.49(s, 6H,  $-\text{Si}(\text{CH}_3)_2$ );  $^{13}\text{C}$  NMR ( $\text{CDCl}_3$ )  $\delta$  132.4, 129.1, 128.5, 122.9, 106.2, 90.9, 0.7; IR (neat,  $\text{cm}^{-1}$ ) 3083, 2962, 2157, 1487, 1443, 1250, 1219, 1069, 1024, 848, 787, 689; GC-MS (EI):  $m/z$  261 ( $\text{M}^{+1}$ , 6), 260 ( $\text{M}^+$ , 23), 246 (23), 245 (100), 202 (6.8), 129 (22), 103 (6), 102 (7), 53 (6).

**Bis(phenylethynyl)dimethylgermane (45).** A solution of dry THF (50 mL) and phenylacetylene (10.2 g, 11 mL, 100 mmol) was added to ethylmagnesium bromide (50 mL, 100 mmol, 2.0 M in THF) to maintain a gentle reflux. After addition the reaction mixture was refluxed for 1h, then allowed to cool to room temperature. The reaction was then cooled to  $-78\text{ }^{\circ}\text{C}$  in a dry ice/acetone bath, and a solution of

dimethyldichlorogermane (8.7 g, 5.8 mL, 50 mmol) in THF (30 mL) was added by syringe. Upon completion of the addition, the reaction mixture was allowed to warm to room temperature and stir for 3 h. The reaction was then quenched in saturated ammonium chloride (200 mL), and extracted with ether (2 x 100 mL). The combined organic portion was washed with water (100 mL), then dried over magnesium sulfate. After solvent removal *in vacuo*, the product was purified by flash chromatography (hexane, silica gel), followed by recrystallization from hexane to give **45** (9.18 g, 30 mmol, 60%) as a white crystalline solid: m.p. 66-68 °C. <sup>1</sup>H NMR (CDCl<sub>3</sub>) δ 7.4(m, 4H, Ar), 7.2(m, 6H, ArH), 0.63(s, 6H, ~Ge(CH<sub>3</sub>)<sub>2</sub>); <sup>13</sup>C NMR (CDCl<sub>3</sub>) δ 132.3, 129.2, 128.5, 122.6, 104.9, 90.6, 1.2; IR (neat, cm<sup>-1</sup>) 3078, 3063, 2969, 2914, 2872, 2159, 1725, 1597, 1488, 1215, 1069, 810, 756, 690, 582; GC-MS (EI): *m/z* 309 (2), 308 (4), 307 (5), 306 (M<sup>+</sup>, 22), 304 (18), 303 (2), 302 (12), 293 (11), 292 (11), 291 (54), 290 (20), 289 (45), 288 (5), 287 (33), 275 (3), 273 (2), 271 (2), 215 (2), 204 (2), 203 (13), 202 (92), 201 (9), 200 (14), 199 (16), 198 (4), 197 (13), 195 (12), 189 (3), 177 (7), 176 (5), 175 (30), 174 (13), 173 (22), 172 (2), 171 (19), 163 (3), 162 (2), 152 (2), 151 (4), 150 (5), 149 (7), 148 (2), 147 (7), 139 (2), 125 (3), 123 (8), 122 (2), 121 (5), 119 (3), 115 (12), 111 (3), 110 (3), 109 (3), 107 (2), 106 (3), 104 (8), 103 (10), 102 (100), 101 (7), 100 (8), 99 (13), 98 (6), 97 (8), 95 (4), 91 (8), 89 (33), 88 (9), 87 (27), 86 (2), 85 (12), 77 (6), 76 (38), 75 (17), 74 (18), 73 (6), 72 (4), 70 (3), 69 (3), 66 (2), 65 (4), 64 (2), 63 (16), 62 (9), 61 (4), 57 (3), 56 (2), 55 (3), 52 (8), 51 (17).

**(Z)-1,1-Dimethyl-2-phenyl-4-(phenylmethylene)silacyclobut-2-ene (4).**

This compound was made according to the literature.<sup>11</sup> To a stirring solution of dry THF (200 mL) and zirconocene dichloride (9.8 g, 33.6 mmol) at -78 °C was added dropwise ethylmagnesium chloride (34.8 mL, 67 mmol, 1.93 M in ether). Upon completion of addition the reaction mixture was allowed to stir for 1 h at -78 °C, then bis(phenylethynyl)dimethylsilane (7.0 g, 26.9 mmol) in THF (10 mL) was added, and the reaction mixture allowed to stir for 1 h, then warm to room temperature. The reaction mixture was quenched with HCl (2 M, 150 mL), and extracted with ether (2 x 100 mL). The combined organic fraction was then washed with saturated sodium



bicarbonate (100 mL), water (100 mL), and sat. sodium chloride (100 mL), then dried over magnesium sulfate. After solvent removal *in vacuo*, the product was purified by recrystallization from hexane, followed by flash chromatography (hexane, silica gel), affording **4** (3.8 g, 14.5 mmol, 54%) as a white crystalline solid (m.p. 98-100 °C). <sup>1</sup>H NMR (CDCl<sub>3</sub>) δ 7.79 (s, 1H, ~C-(H)C=C(Ph)~), 7.42-7.25 (m, 10H, ArH), 6.81 (s, 1H, Ph(H)C=C~), 0.66 (s, 6H, ~Si(CH<sub>3</sub>)<sub>2</sub>); <sup>13</sup>C 158.6, 149.1, 146.2, 139.5, 137.2, 128.8, 128.8, 128.7, 127.9, 126.9, 126.8, 126.2, -0.6; IR (neat, cm<sup>-1</sup>) 3100, 3083, 3042, 1949, 1591, 1251, 951, 843; UV λ<sub>max</sub> (THF) 336 nm; MS: 264 (M<sup>+</sup>, 6), 263 (M<sup>+</sup>, 28), 262 (M<sup>+</sup>, 100), 248 (7), 247 (29), 246 (7), 245 (27), 204 (12), 203 (16), 202 (17), 169 (9), 159 (7), 146 (8), 145 (46), 143 (9), 135 (6), 131 (8), 129 (9), 123 (6), 121 (11), 119 (6), 115 (6), 105 (28), 103 (5), 102 (9), 77 (7), 58 (11), 53 (7); HRMS (EI) *m/z* calcd for C<sub>18</sub>H<sub>18</sub>Si 262.11770, found 262.118222.

**Photolysis of 4; (E)-1,1-dimethyl-4-phenyl-2-(phenylmethylene)-silacyclobut-2-ene (33).** A solution of **4** (0.5 g, 1.9 mmol, 0.05 M in hexane) was prepared and sparged with argon. Photolysis was carried out in a Pyrex test tube under argon at 350 nm for 2.5 h. The resulting material, after solvent removal *in vacuo*, was an oil that consisted of an inseparable mixture of **4** and **33** (0.5 g, 1.9 mmol, quantitative yield 1:1 mixture of isomers). NMR data was obtained by subtraction. **33** <sup>1</sup>H NMR (CDCl<sub>3</sub>) δ 8.31 (s, 1H, C-(H)C=C(Ph)~), 7.42-7.33 (m, 10H, ArH), 6.42, (s, 1H, Ph(H)C=C~), 0.54 (s, 6H, ~Si(CH<sub>3</sub>)<sub>2</sub>); <sup>13</sup>C NMR (CDCl<sub>3</sub>) δ 161.97, 145.6, 145.5, 139.5, 137.3, 128.8, 128.5, 128.3, 128.13, 127.2, 126.5, 126.0, -1.3.

**(Z,E)-1,4-diphenyl-1-(ethoxydimethylsilyl)-1,3-butadiene (31).** A solution of **4** (0.114 g, 0.43 mmol) in ethanol (100 mL) was prepared and allowed to stir overnight over molecular sieves. The solvent was removed *in vacuo*, and the product dissolved in hexane (75 mL) and dried over magnesium sulfate. The product **31** (0.132 g, 0.43 mmol, quantitative) was obtained as a clear oil without further purification. <sup>1</sup>H NMR (CDCl<sub>3</sub>) δ 7.58 (dd, *J* = 15.3, 11.4 Hz, 1H, Ph(H)C=C(H)-(H)C=C~), 7.42-7.17 (m, 10H, ArH), 6.92 (dd, *J* = 11.4, 0.6 Hz, 1H, Ph(H)C=C(H)-(H)C=C~), 6.67 (d, *J* = 15.3 Hz, 1H, Ph(H)C=C(H)-(H)C=C~), 3.75 (q, *J* = 7.2 Hz, 2H, ~SiCH<sub>2</sub>CH<sub>3</sub>), 1.26 (t, *J* = 7.2 Hz, 3H, ~SiOCH<sub>2</sub>CH<sub>3</sub>), 0.34 (s, 6H, ~Si(CH<sub>3</sub>)<sub>2</sub>); <sup>13</sup>C

NMR (CDCl<sub>3</sub>) δ 146.1, 145.6, 144.7, 137.6, 136.0, 128.9, 128.4, 128.2, 128.0, 127.5, 126.8, 126.2, 58.7, 18.6, 0.54; IR (neat, cm<sup>-1</sup>) 3056, 2969, 2897, 1595, 1487, 1254, 1102, 1077, 971, 818, 786, 748, 690; GC-MS (EI): *m/z* 309 (M<sup>+1</sup>, 4), 308 (M<sup>+</sup>, 16), 249 (6), 247 (10), 245 (10), 205 (13), 204 (53), 203 (16), 202 (12), 145 (11), 137 (5), 135 (5), 128 (5), 121 (12), 105 (8), 104 (11), 103 (100), 89 (12), 75 (42), 70 (11), 59 (17); HRMS (EI) *m/z* calcd for C<sub>20</sub>H<sub>24</sub>OSi 308.15964, found 308.16024.

**(Z,E)-1,4-diphenyl-1-(methoxydimethylsilyl)-1,3-butadiene (32).** A solution of **4** (0.050 g, 0.2 mmol) in methanol (100 mL) was prepared and allowed to stir for 2 h over molecular sieves. The solvent was then removed *in vacuo* and the product dissolved in hexane (75 mL) and dried over magnesium sulfate. After solvent removal *in vacuo*, the product **32** (0.058 g, 0.2 mmol, quantitative) was obtained as a clear oil without further purification. <sup>1</sup>H NMR (CDCl<sub>3</sub>) δ 7.51-7.14 (m, 11H), 6.92 (d(br), *J* = 11.4 Hz, 1H, Ph(H)C=C(H)-(H)C=C~), 6.65 (d, *J* = 15Hz, 1H, Ph(H)C=C(H)-(H)C=C~), 3.43 (s, 3H, ~SiOCH<sub>3</sub>), 0.31, (s, 6H, ~Si(CH<sub>3</sub>)<sub>2</sub>); <sup>13</sup>C NMR (CDCl<sub>3</sub>) δ 145.8, 145.6, 143.9, 137.4, 136.2, 128.8, 128.2, 127.9, 127.4, 126.8, 126.7, 126.1, 50.9, 1.1; GC-MS-IR (cm<sup>-1</sup>) 3067, 2967, 2839, 2143, 1594, 1261, 1096, 825; GC-MS (EI): *m/z* 295 (M<sup>+1</sup>, 4), 294 (M<sup>+</sup>, 15), 247 (7), 205 (8), 204 (63), 203 (8), 202 (5), 151 (5), 89 (100), 75 (20), 59 (32); HRMS (EI) *m/z* calcd for C<sub>19</sub>H<sub>21</sub>OSi 296.16399, found 296.16645.

**Photolysis of 4, products after quenching with ethanol; 31 and (E,E)-1,4-diphenyl-2-(ethoxydimethylsilyl)-1,3-butadiene (36).** A solution of **4** (0.5 g, 1.9 mmol, 0.05 M in hexane) was photolyzed at 350 nm for 2.5 h. The product was then dissolved in ethanol (100 mL) and allowed to stir overnight. Solvent removal was performed *in vacuo*. The crude product was then dissolved in hexane (75 mL) and dried over magnesium sulfate. Solvent removal *in vacuo* then gave a mixture of **31** and **36** (0.58 g, 1.9 mmol, quantitative 1:1 mixture of isomers) as a clear oil. **31** <sup>1</sup>H NMR (CDCl<sub>3</sub>) δ 7.58 (dd, *J* = 15.3, 11.4 Hz, 1H, Ph(H)C=C(H)-(H)C=C~), 7.42-7.17 (m, 10H), 6.92 (dd, *J* = 11.4, 0.6 Hz, 1H, Ph(H)C=C(H)-(H)C=C~), 6.67 (d, *J* = 15.3 Hz, 1H, Ph(H)C=C(H)-(H)C=C~), 3.75 (q, *J* = 7.2 Hz, 2H, ~SiOCH<sub>2</sub>CH<sub>3</sub>), 1.26 (t, *J* = 7.2 Hz, 3H, ~SiOCH<sub>2</sub>CH<sub>3</sub>), 0.34 (s, 6H, ~Si(CH<sub>3</sub>)<sub>2</sub>); <sup>13</sup>C NMR (CDCl<sub>3</sub>) δ 146.1, 145.6,

144.7, 137.6, 136.0, 128.9, 128.4, 128.2, 128.0, 127.5, 126.8, 126.2, 58.7, 18.6, 0.54; IR (neat,  $\text{cm}^{-1}$ ) 3056, 2969, 2897, 1595, 1487, 1254, 1102, 1077, 971, 818, 786, 748, 690; GC-MS (EI):  $m/z$  309 ( $M^+$ , 4), 308 ( $M^+$ , 16), 249 (6), 247 (10), 245 (10), 205 (13), 204 (53), 203 (16), 202 (12), 145 (11), 137 (5), 135 (5), 128 (5), 121 (12), 105 (8), 104 (11), 103 (100), 89 (12), 75 (42), 70 (11), 59 (17).  $^{36} \text{H}$  NMR ( $\text{CDCl}_3$ )  $\delta$  7.52-7.23 (m, 11H), 7.00 (d,  $J = 16.5$  Hz, 1H,  $\text{Ph(H)C}=\text{C(Si-)}$ - $(\text{H})\text{C}=\text{C(H)Ph}$ ), 7.01 (s, 1H,  $\text{Ph(H)C}=\text{C(Si-)}$ - $(\text{H})\text{C}=\text{C(H)Ph}$ ), 3.8 (q,  $J = 7.2$  Hz, 2H,  $\sim\text{SiOCH}_2\text{CH}_3$ ), 1.30 (t,  $J = 7.2$  Hz, 3H,  $\sim\text{SiOCH}_2\text{CH}_3$ ), 0.44 (s, 6H,  $\sim\text{Si}(\text{CH}_3)_2$ );  $^{13}\text{C}$  NMR ( $\text{CDCl}_3$ )  $\delta$  141.6, 139.1, 137.6, 132.6, 129.0, 128.8, 128.4, 127.7, 127.5, 126.6, 58.9, 18.7, -1.0; GC-MS (EI):  $m/z$  309 ( $M^+$ , 1), 308 ( $M^+$ , 5), 247 (3), 245 (2), 205 (8), 204 (34), 203 (9), 202 (7), 173 (4), 145 (5), 135 (4), 128 (4), 105 (5), 104 (10), 103 (100), 77 (4), 76 (4), 75 (38), 70 (4), 59 (14).

**Photolysis of 4 in methanol- $d_4$ ; (*Z,Z*)-1,4-diphenyl-1-(methoxy- $d_3$ -dimethylsilyl)-1,3-butadiene-3d (34D) and (*Z,E*)-1,4-diphenyl-1-(methoxy- $d_3$ -dimethylsilyl)-1,3-butadiene-3d (32D).** A solution of 2 (0.022 g, 0.084 mmol) in methanol- $d_4$  (2 mL) was prepared and sparged with argon. The solution was subjected to photolysis in an NMR tube at 350 nm for 5 h and monitored by  $^1\text{H}$  NMR. An inseparable isomeric mixture was obtained, NMR was obtained by subtraction and yields determined by NMR; 34D (70%) and 32D (26%).  $^{32}\text{D}$   $^1\text{H}$  NMR ( $\text{CDCl}_3$ )  $\delta$  7.42-7.10 (m, 10H), 6.92 (s, 1H,  $\text{Ph(H)C}=\text{C(D)}-\text{(H)C}=\text{C-}$ ), 6.66 (s, 1H,  $\text{Ph(H)C}=\text{C(D)}-\text{(H)C}=\text{C-}$ ), 0.32 (s, 6H,  $\sim\text{Si}(\text{CH}_3)_2$ );  $^{13}\text{C}$  NMR ( $\text{CDCl}_3$ )  $\delta$  145.8, 145.6, 143.9, 137.4, 136.2, 128.8, 128.2, 128.0, 127.9, 127.4, 126.8, 126.7, 126.1, 50.9, 1.09; GC-MS-IR ( $\text{cm}^{-1}$ ) 3066, 3025, 2215, 2067, 1597, 1441, 1262, 1133, 998, 919, 893, 818; GC-MS (EI):  $m/z$  298 ( $M^+$ , 17), 248 (12), 246 (5), 209 (10), 208 (15), 206 (13), 205 (60), 204 (14), 203 (9), 191 (8), 154 (7), 133 (5), 96 (8), 94 (6), 93 (10), 92 (100), 78 (13), 62 (7), 60 (25).  $^{34}\text{D}$   $^1\text{H}$  NMR ( $\text{CDCl}_3$ )  $\delta$  7.42-7.10 (m, 10H), 6.81 (s, 1H,  $\text{Ph(H)C}=\text{C(D)}-\text{(H)C}=\text{C-}$ ), 6.72 (s, 1H,  $\text{Ph(H)C}=\text{C(D)}-\text{(H)C}=\text{C-}$ ), 0.23 (s, 6H,  $\sim\text{Si}(\text{CH}_3)_2$ );  $^{13}\text{C}$  NMR ( $\text{CDCl}_3$ )  $\delta$  144.4, 141.4, 140.2, 137.2, 135.3, 128.6, 128.4, 128.3, 128.2, 127.9, 127.4, 126.8, 126.1, 2.5; GC-MS-IR ( $\text{cm}^{-1}$ ) 3066, 3025, 2215, 2067, 1597, 1441, 1262, 1133, 998, 919, 893, 818; GC-MS (EI):  $m/z$  299 ( $M^+$ , 6), 298 ( $M^+$ , 26), 283 (5),

263 (5), 248 (15), 249 (3), 246 (7), 206 (15), 205 (65), 204 (14), 203 (9), 154 (5), 146 (4), 94 (4), 93 (9), 92 (100), 78 (6), 62 (6), 60 (24).

**Photolysis of 4 in methanol; (Z,Z)-1,4-diphenyl-1-(methoxydimethylsilyl)-1,3-butadiene (32), and (Z,E)-1,4-diphenyl-1-(methoxydimethylsilyl)-1,3-butadiene (34).** A degassed solution of **2** (0.012 g, 0.046 mmol) in methanol was photolyzed in a NMR tube at 350 nm for 45 min. A clear oil was obtained which consisted of an inseparable isomeric mixture **32** (12%) and **34** (78%), yields by NMR. **32**  $^1\text{H}$  NMR ( $\text{CDCl}_3$ )  $\delta$  7.51-7.14 (m, 11H), 6.92 (d(broad),  $J = 11.4$  Hz, 1H,  $\text{Ph}(\text{H})\text{C}=\text{C}(\text{H})-(\text{H})\text{C}=\text{C}\sim$ ), 6.65 (d,  $J = 15$  Hz, 1H,  $\text{Ph}(\text{H})\text{C}=\text{C}(\text{H})-(\text{H})\text{C}=\text{C}\sim$ ), 3.43 (s, 3H,  $\sim\text{SiOCH}_3$ ), 0.31, (s, 6H,  $\sim\text{Si}(\text{CH}_3)_2$ );  $^{13}\text{C}$  NMR ( $\text{CDCl}_3$ )  $\delta$  145.8, 145.6, 143.9, 137.4, 136.2, 128.8, 128.2, 127.9, 127.4, 126.8, 126.7, 126.1, 50.9, 1.1; GC-MS-IR ( $\text{cm}^{-1}$ ) 3067, 2967, 2839, 2143, 1594, 1261, 1096, 825; GC-MS (EI):  $m/z$  295 ( $\text{M}^{+1}$ , 4), 294 ( $\text{M}^+$ , 15), 247 (7), 205 (8), 204 (63), 203 (8), 202 (5), 151 (5), 89 (100), 75 (20), 59 (32). **34**  $^1\text{H}$  NMR ( $\text{CDCl}_3$ )  $\delta$  7.42-7.10 (m, 10H), 6.82 (dd,  $J = 8.4, 7.5$  Hz, 1H,  $\text{Ph}(\text{H})\text{C}=\text{C}(\text{H})-(\text{H})\text{C}=\text{C}\sim$ ), 6.75 (dd,  $J = 13.0, 8.0$  Hz, 1H,  $\text{Ph}(\text{H})\text{C}=\text{C}(\text{H})-(\text{H})\text{C}=\text{C}\sim$ ), 6.64 (dd,  $J = 15.3, 0.6$  Hz, 1H,  $\text{Ph}(\text{H})\text{C}=\text{C}(\text{H})-(\text{H})\text{C}=\text{C}\sim$ ), 3.47 (s, 3H,  $\sim\text{SiOCH}_3$ ), 0.23 (s, 6H,  $\sim\text{Si}(\text{CH}_3)_2$ );  $^{13}\text{C}$  NMR ( $\text{CDCl}_3$ )  $\delta$  145.8, 145.6, 143.9, 137.4, 136.2, 128.8, 128.2, 128.0, 127.9, 127.4, 126.8, 126.7, 126.1, 50.9, 1.09; GC-MS-IR ( $\text{cm}^{-1}$ ) 3067, 2839, 1596, 14491, 1259, 1098, 945, 821; GC-MS (EI):  $m/z$  295 ( $\text{M}^{+1}$ , 8), 294 ( $\text{M}^+$ , 31), 262 (7), 247 (24), 245 (13), 205 (22), 204 (95), 203 (23), 202 (16), 151 (14), 145 (9), 121 (9), 91 (6), 90 (8), 89 (100), 75 (19), 59 (28).

**Bis(phenyl- $d_5$ -ethynyl)dimethylsilane (37).** A mixture of bis(ethynyl)dimethylsilane (0.15 g, 1.4 mmol), bis(triphenylphosphine) palladium (II) chloride (0.034 g, 0.048 mmol), copper iodide (0.0046 g, 0.024 mmol), iodobenzene- $d_5$  (0.505 g, 2.4 mmol) in triethylamine (15 mL) was heated to 50 °C for 6 h. The insoluble salts were filtered out, and the product purified by flash chromatography (1:30 ethyl acetate:hexane). Solvent removal *in vacuo* provided the product **37** (0.28 g, 1.02 mmol, 85% yield), as a yellowish solid m.p. 77-78 °C.  $^1\text{H}$  NMR ( $\text{CDCl}_3$ )  $\delta$  0.51 (s, 6H,  $\sim\text{Si}(\text{CH}_3)_2$ );  $^{13}\text{C}$  NMR ( $\text{CDCl}_3$ )  $\delta$  122.9, 106.2, 90.9, 0.7; IR (neat,  $\text{cm}^{-1}$ )

2964, 2283, 2159, 1614, 1561, 1404, 1375, 1251, 1162, 1035, 853, 805. GC-MS (EI):  $m/z$  271 ( $M^{+1}$ , 6), 270 ( $M^+$ , 24), 257 (6), 256 (23), 255 (100), 212 (8), 134 (15). HRMS (EI)  $m/z$  calcd for  $C_{18}H_6D_{10}Si$  270.16490, found 270.165203.

**1,1-Dimethyl-2-(phenyl- $d_5$ )-4-(phenyl- $d_5$ -methylene)silacyclobut-2-ene (38).** To a stirring solution of THF (15 mL) and zirconocene dichloride (0.43 g, 1.48 mmol) at  $-78$  °C was added ethylmagnesium bromide (1.48 mL, 2.96 mmol, 2 M in ether). The solution was allowed to stir for 1 h at  $-78$  °C, then a solution of **37** (0.32 g, 1.2 mmol) in THF (2 mL) was added. The reaction mixture was allowed to stir for 1.5 h then warm to room temperature. The reaction mixture was quenched in HCl (2 M, 50 mL) and extracted with ether (2 x 50 mL). The organic fraction was then washed with sat. sodium bicarbonate (50 mL), water (50 mL), and 1x sat. sodium chloride (50 mL), then dried over magnesium sulfate. Flash chromatography (hexane, silica gel), followed by solvent removal *in vacuo*, gave **38** (0.16 g, 0.6 mmol, 50%) as a white crystalline powder m.p. 98-100 °C.  $^1H$  NMR ( $CDCl_3$ )  $\delta$  7.81 (s, 1H,  $\sim C-(H)C=C(Ph)\sim$ ), 6.83 (s, 1H,  $Ph(H)C=C\sim$ ), 0.65 (s, 6H,  $\sim Si(CH_3)_2$ );  $^{13}C$  NMR ( $CDCl_3$ )  $\delta$  158.6, 149.2, 146.3, 139.6, 137.3, 128.8, -0.6.; IR (neat,  $cm^{-1}$ ) 3100, 3042, 2283, 1949, 1591, 1251, 951, 843; GC-MS (EI):  $m/z$  274 ( $M^{+2}$ , 6), 253 ( $M^{+1}$ , 25), 272 ( $M^+$ , 100), 271 (6), 258 (7), 257 (29), 254 (13), 253 (10), 214 (11), 213 (6), 212 (10), 211 (8), 210 (9), 164 (6), 151 (6), 150 (36), 149 (36), 140 (6), 136 (6), 134 (9), 126 (12), 110 (28), 107 (11), 58 (13), 54 (9), 53 (6); HRMS (EI)  $m/z$  calcd. for  $C_{18}H_8D_{10}Si$  272.18055, found 271.18109.

**Photolysis of 38; (E)-1,1-dimethyl-2-(phenyl- $d_5$ )-4-(phenyl- $d_5$ -methylene)silacyclobut-2-ene (39).** A solution of **38** (0.015 g, 0.055 mmol) in benzene- $d_6$  (1 mL) was photolyzed at 350 nm in an NMR tube for 1.2 h. The reaction mixture was monitored by  $^1H$  NMR. The isomerization product was observed by NMR; **39** (45% NMR yield). The NMR was obtained by subtraction. **39**  $^1H$  NMR ( $CDCl_3$ )  $\delta$  8.29 (s, 1H,  $\sim C-(H)C=C\sim$ ), 6.43 (s, 1H,  $Ph(H)C=C\sim$ ), 0.42 (s, 6H,  $\sim Si(CH_3)_2$ );  $^{13}C$  NMR ( $CDCl_3$ )  $\delta$  161.9, 145.6, 145.5, 139.5, 137.3, 128.8, -1.3

**(Z,E)-1,4-(diphenyl-d<sub>5</sub>)-1-(ethoxydimethylsilyl)-1,3-butadiene (41).** A solution of **38** (0.01 g, 0.037 mmol) was stirred in ethanol (50 mL) overnight over molecular sieves. The solvent was removed *in vacuo* and the product dissolved in hexane (75 mL) and dried over magnesium sulfate. After solvent removal *in vacuo*, the product **41** (0.011 g, 0.037 mmol, quantitative) was recovered as a clear oil without further purification. <sup>1</sup>H NMR (CDCl<sub>3</sub>) δ 7.54 (dd, *J* = 15.3, 11.4 Hz, 1H, Ph(H)C=C(H)-(H)C=C~), 6.9 (dd, *J* = 11.4, 0.6 Hz, 1H, Ph(H)C=C(H)-(H)C=C~), 6.64 (dd, *J* = 15.3, 0.6 Hz, 1H, Ph(H)C=C(H)-(H)C=C~), 3.71 (q, *J* = 7.2, 2H, ~SiOCH<sub>2</sub>CH<sub>3</sub>), 1.22 (t, *J* = 7.2 Hz, 3H, ~SiOCH<sub>2</sub>CH<sub>3</sub>), 0.32 (s, 6H, ~Si(CH<sub>3</sub>)<sub>2</sub>); <sup>13</sup>C NMR (CDCl<sub>3</sub>) δ 145.6, 144.5, 137.4, 135.9, 128.2, 58.6, 18.4, 0.4; GC-MS (EI): *m/z* 319 (M<sup>+1</sup>, 4), 318 (M<sup>+</sup>, 16), 256 (6), 214 (10), 213 (29), 212 (8), 211 (8), 210 (6), 149 (7), 142 (5), 140 (5), 133 (5), 126 (11), 104 (10), 103 (100), 89 (11), 76 (8), 75 (48), 59 (22).

**Photolysis of 4, products after quenching with ethanol; 31 and (E,Z)-1,4-diphenyl-2-(ethoxydimethylsilyl)-1,3-butadiene (36).** A solution of **4** (0.025 g, 0.09 mmol) in hexane (20 mL) was photolyzed at 350 nm for 2 h. Upon completion, the product was stirred in ethanol (75 mL) overnight over molecular sieves. After solvent removal *in vacuo*, the product, an inseparable mixture of **31** and **36** (0.027 g, quantitative, in a 1:1 ratio **31:36**), was obtained as a clear oil. **31** <sup>1</sup>H NMR (CDCl<sub>3</sub>) δ 7.54 (dd, *J* = 15.3, 11.4 Hz, 1H, Ph(H)C=C(H)-(H)C=C~), 6.9 (dd, *J* = 11.4, 0.6 Hz, 1H, Ph(H)C=C(H)-(H)C=C~), 6.64 (dd, *J* = 15.3, 0.6 Hz, 1H, Ph(H)C=C(H)-(H)C=C~), 3.71 (q, *J* = 7.2 Hz, 2H, ~SiOCH<sub>2</sub>CH<sub>3</sub>), 1.22 (t, *J* = 7.2 Hz, 3H, ~SiOCH<sub>2</sub>CH<sub>3</sub>), 0.32 (s, 6H, ~Si(CH<sub>3</sub>)<sub>2</sub>); <sup>13</sup>C NMR (CDCl<sub>3</sub>) δ 146.1, 145.6, 144.7, 137.6, 136.0, 128.9, 128.4, 128.2, 128.0, 127.5, 126.8, 126.2, 58.7, 18.6, 0.54; GC-MS (EI): *m/z* 319 (M<sup>+1</sup>, 4), 318 (M<sup>+</sup>, 16), 256 (6), 214 (10), 213 (29), 212 (8), 211 (8), 210 (6), 149 (7), 142 (5), 140 (5), 133 (5), 126 (11), 104 (10), 103 (100), 89 (11), 76 (8), 75 (48), 59 (22). **36** <sup>1</sup>H NMR (CDCl<sub>3</sub>) δ 7.30 (dd, *J* = 16.5, 0.9 Hz, 1H, Ph(H)C=C(Si~)-(H)C=C(H)Ph), 6.97 (d, *J* = 16.5 Hz, 1H, Ph(H)C=C(Si~)-(H)C=C(H)Ph), 6.96 (s, 1H, Ph(H)C=C(Si~)-(H)C=C(H)Ph), 3.71 (q, *J* = 7.2 Hz, 2H, ~SiOCH<sub>2</sub>CH<sub>3</sub>), 1.26 (t, *J* = 7.2 Hz, 3H, ~SiCH<sub>2</sub>CH<sub>3</sub>), 0.42 (s, 6H, ~Si(CH<sub>3</sub>)<sub>2</sub>); <sup>13</sup>C

NMR (CDCl<sub>3</sub>) δ 141.6, 139.1, 138.3, 137.6, 132.6, 129.9, 129.0, 128.8, 128.4, 127.7, 127.5, 126.6, 58.8, 18.6, 1.3; GC-MS (EI): *m/z* 318 (M<sup>+</sup>, 7), 214 (7), 213 (25), 140 (5), 104 (5), 104 (10), 103 (100), 75 (41), 59 (17).

**Photolysis of 31; photoisomerization to (Z,Z)-1,4-diphenyl-1-(dimethylethoxysilyl)-1,3-butadiene (35).** A solution of **4** (0.082 g, 0.313 mmol) in ethanol (150 mL) was stirred in a test tube until conversion to **31** was complete. The solution was then degassed and photolyzed at 350 nm under argon for 2 h. Solvent removal *in vacuo* gave an inseparable mixture of **31** and **35** (0.93 g, 0.313 mmol, quantitative in a 1:4 ratio **31:35**) as a clear oil. **35** <sup>1</sup>H NMR (CDCl<sub>3</sub>) δ 7.4-7.2 (m, 11H), 6.88 (m, 2H), 6.85 (m, 1H), 3.75 (q, *J* = 7.2, 2H, ~SiOCH<sub>2</sub>CH<sub>3</sub>), 1.25 (t, *J* = 6.9 Hz, 3H, ~SiOCH<sub>2</sub>CH<sub>3</sub>), 0.28 (s, 6H, ~Si(CH<sub>3</sub>)<sub>2</sub>); <sup>13</sup>C NMR (CDCl<sub>3</sub>) δ 145.0, 141.6, 140.1, 137.3, 135.3, 128.7, 128.5, 128.3, 127.9, 126.8, 126.13, 126.1, 58.8, 18.6, -1.9; IR (neat, cm<sup>-1</sup>) 3075, 3026, 1596, 1488, 1446, 1446, 1389, 1252, 1103, 1074, 970, 947, 831, 816, 785, 749, 700; GC-MS (EI): *m/z* 309 (M<sup>+</sup>, 3), 308 (M<sup>+</sup>, 12), 249 (4), 247 (7), 245 (3), 205 (9), 204 (36), 203 (11), 202 (9), 173 (4), 145 (9), 137 (5), 135 (5), 128 (5), 121 (11), 115 (4), 105 (8), 104 (10), 103 (100), 91 (4), 89 (14), 77 (7), 76 (5), 75 (52), 73 (5), 61 (17), 59 (23).

**Photolysis of 41; photoisomerization to (Z,Z)-1,4-(diphenyl-d<sub>5</sub>)-1-(dimethylethoxysilyl)-1,3-butadiene (42).** A solution of **38** (0.01 g, 0.037 mmol) in ethanol (5 mL) was stirred overnight over molecular sieves. Next the solvent was removed *in vacuo* and the clear oil dissolved in hexane (50 mL) and dried over magnesium sulfate. The solution was then degassed by means of sparging and photolyzed at 350nm for 4 h under argon. After solvent removal *in vacuo*, the isomer **42** (0.01 g, 0.037 mmol) was obtained as a clear oil. <sup>1</sup>H NMR (CDCl<sub>3</sub>) δ 6.88 (m, 2H), 6.85 (m, 1H), 3.75 (q, *J* = 7.2 Hz, 2H, ~SiOCH<sub>2</sub>CH<sub>3</sub>), 1.25 (t, *J* = 6.9 Hz, 3H, ~SiOCH<sub>2</sub>CH<sub>3</sub>), 0.28 (s, 6H, ~Si(CH<sub>3</sub>)<sub>2</sub>); <sup>13</sup>C NMR (CDCl<sub>3</sub>) δ 145.0, 141.6, 140.1, 137.3, 135.3, 127.9, 58.8, 18.6, -1.9; GC-MS (EI): *m/z* 319 (M<sup>+</sup>, 4), 318 (M<sup>+</sup>, 17), 303 (3), 259 (4), 257 (3), 256 (5), 215 (4), 214 (9), 213 (29), 212 (7), 211 (8), 210 (6), 209 (4), 207 (3), 177 (3), 150 (3), 149 (7), 140 (4), 134 (2), 133 (5), 132 (3), 131 (2), 128 (2), 127 (3), 126 (10), 120 (1), 119 (2), 110 (3), 109 (2), 107 (3), 106 (2), 105

(5), 104 (10), 103 (100), 96 (3), 90 (3), 89 (11), 82 (2), 81 (3), 80 (2), 77 (2), 76 (8), 75 (45), 73 (5), 62 (2), 61 (16), 60 (4), 59 (21), 58 (2), 54 (3).

### References

- (1) Barton, T. J.; Lin, J.; Ijadi-Maghsoodi, S.; Power, M. D.; Zhang, X.; Ma, Z.; Shimizu, H.; Gordon, M. S. *J. Am. Chem. Soc.* **1995**, *117*, 11695.
- (2) Chan, T. H.; Massuda, D. *J. Am. Chem. Soc.* **1977**, *99*, 936.
- (3) Chen, N.; Jones, M. J. *J. Phys. Org. Chem.* **1988**, *1*, 305.
- (4) Barton, T. J.; Yeh, M. H. *Tetrahedron Lett.* **1987**, *28*, 6421.
- (5) Eaton, P. E.; Hoffman, K. *J. Am. Chem. Soc.* **1987**, *109*, 5285.
- (6) Barton, T. J. *Dow Coming Corporate Lecture Series* **1988**, 273.
- (7) Barton, T. J. *Organometallics* **1985**, *4*, 575.
- (8) Flowers, M. C.; Gusel'nikov, L. E. *J. Chem. Soc. B* **1968**, 428, 1396.
- (9) Takahashi, T.; Xi, Z.; Obora, Y.; Suzuki, N. *J. Am. Chem. Soc.* **1995**, *117*, 2665.
- (10) Conlin, R. T.; Namavari, M. *J. Organomet. Chem.* **1989**, *376*, 259.
- (11) Xi, Z.; Fischer, R.; Hara, R.; Sun, W.-H.; Obora, Y.; Suzuki, N.; Nakajima, K.; Takahashi, T. *J. Am. Chem. Soc.* **1997**, *119*, 12842.
- (12) Damrauer, R. *Organomet. Chem. Rev. A* **1972**, *8*, 67.
- (13) Tzeng, D.; Fong, R. H.; Soysa, D.; Weber, W. P. *J. Organomet. Chem.* **1981**, *219*, 153.
- (14) Steinmetz, M. G.; Udayakumar, B. S. *Organometallics* **1989**, *8*, 530.
- (15) Yee, W. A.; Hug, S. J.; Kliger, D. S. *J. Am. Chem. Soc.* **1988**, *110*, 2164.
- (16) Valkovich, P. B.; Weber, W. P. *Tetrahedron Lett.* **1975**, *26*, 2153.
- (17) Ibekwe, S. D.; Newlands, M. J. *J. Chem. Soc.* **1965**, 4608.



## GENERAL CONCLUSION

The driving force behind much of the work in this dissertation was to gain further understanding of the unique olefin to carbene isomerization observed in the thermolysis of 1,1-dimethyl-2-methylenesilacyclobutane by finding new examples of it in other silicon and germanium compounds. This led to the examination of a novel phenylmethylenesilacyclobut-2-ene, which did not undergo olefin to carbene rearrangement. A synthetic route to methylenegermacyclobutanes was developed, but the methylenegermacyclobutane system exhibited kinetic instability, making the study of the system difficult. In any case the germanium system decomposed through a complex mechanism which may not include olefin to carbene isomerization. However, this work led to the study of the gas phase thermochemistry of a series of dialkylgermylene precursors in order to better understand the mechanism of the thermal decomposition of dialkylgermylenes. The resulting dialkylgermylenes were found to undergo a reversible intramolecular  $\beta$  C-H insertion mechanism.

Chapter 1 describes the synthesis and study of a series of methylenegermacyclobutanes. Synthesis was accomplished through the Barbier-type coupling of 2,4-dibromo-1-butene and dialkyldichlorogermanes with activated magnesium. Thus, 1,1-dimethyl-2-methylenegermacyclobutane and 1,1-diethyl-2-methylenegermacyclobutane were synthesized and observed spectroscopically, but could not be isolated due to their decomposition. 1,1-Dibutyl-2-methylenegermacyclobutane and 1-methyl-2-methylene-1-phenylgermacyclobutane were obtained in low yield and could be isolated. The novel germacyclic system 2,4-dimethylene-1,1,3,3-tetramethyl-1,3-digermacyclobutane was synthesized by magnesium homocoupling of ( $\alpha$ -bromovinyl)dimethylchlorogermane, but could not be isolated. Only 1,1-dibutyl-2-methylenegermacyclobutane could be isolated and had a sufficient lifetime for study. The thermal rearrangement of 1-dibutyl-2-methylenegermacyclobutane to 1,1-dibutyl-1-germacyclopent-3-ene and 1,1-dibutyl-

1-germacyclopent-2-ene was observed as a minor pathway. Germylene extrusion is thought to be a major decomposition pathway. However the expected insertion product of the germylene into the starting material to give 1,1,2,2-tetrabutyl-3-methylene-1,2-digermacyclopentane, was not observed. Trapping experiments with 2,3-dimethyl-1,3-butadiene similarly did not provide any evidence for the presence of germylenes.

Chapter 2 describes the synthesis and thermolysis of a series of germanium compounds in order to further examine the mechanism of dialkylgermylene decomposition. Thus, the thermal decomposition of a series of di-*n*-hexylgermylene precursors was investigated and their Arrhenius parameters compared to literature values where possible. A mechanism of intramolecular  $\beta$  C-H insertion to form an intermediate germirane, followed by either elimination of hexene or a 1,2-hydrogen shift to reform germylene was proposed. This process allows the migration of germanium up and down the alkyl chain. The presence of the 1,2-hydrogen shift was demonstrated by the observation of deuterium incorporation in the hexenes produced from the deuterium labeled precursors (hexylgermane- $d_3$ , dihexylgermane- $d_2$ , and trihexylgermane- $d$ ). The mechanisms of the decomposition of these precursors are complex, and most likely include more than one pathway operating simultaneously. Surface effects were observed in the decompositions (over a Ge/C coated reactor) of precursors containing a Ge-H bond. Under those conditions, the distribution of hexene isomers produced was shifted in favor of 1-hexene. It is proposed that a surface reaction which forms a layer of hexylated germanium could occur, and that consecutive elimination of 1-hexene from this layer would explain the relative increase in 1-hexene observed. The proposed mechanism for the decomposition of the dialkylgermylene was further supported by demonstrating the presence of key intermediates. The intermediacy of dialkylgermylene and alkylgermylene was shown by means of trapping experiments with 2,3-dimethyl-1,3-butadiene in the thermolysis of the low temperature germylene precursor ethylmethyl(trimethylsilyl)germane.

Chapter 3 describes the flow pyrolysis of diallyldimethylgermane (1). Arrhenius parameters of  $E_a = 54.2 \pm 0.8$  kcal/mol and  $\text{Log}(A/s^{-1}) = 13.36 \pm 0.2$  were measured. The main decomposition pathway is proposed to be through consecutive Ge-C homolytic cleavage of the allyl groups.

Chapter 4 describes the thermal and photolytic behavior of (*Z*)-1,1-dimethyl-2-phenyl-4-(phenylmethylene)silacyclobut-2-ene. Photolysis at 350 nm or thermolysis in a sealed tube at 250 °C gave the same product, apparently through *cis-trans* isomerization of the external phenylmethylene moiety. Thus, the result was inevitably an inseparable mixture of (*E*)-1,1-dimethyl-2-phenyl-4-(phenylmethylene)silacyclobut-2-ene and starting material in a 1:1 ratio. Derivatization of the compounds through alcoholysis for the purposes of characterization produced ring opened products (*E,Z*)-1,4-diphenyl-1-(ethoxydimethylsilyl)-1,3-butadiene, and (*E,E*)-1,4-diphenyl-2-(ethoxydimethylsilyl)-1,3-butadiene, which also proved to be inseparable.

## **ACKNOWLEDGMENTS**

First I would like to express my sincere thanks and appreciation to my major professor, Thomas J. Barton, for his guidance, inspiration, encouragement and patience during the course of this work. In many ways, his guidance has helped shape me not only as a chemist, but as a person.

I would like to thank Dr. Sina Ijad-Maghsoodi for invaluable discussions and advice, and Mrs. Kathie Hawbaker, whose help has been greatly appreciated. In addition, I would like to thank former group members Andrew M. Chubb and Mike Serby for valuable discussions, chemistry related and otherwise. I would also like to thank all the faculty, staff and students who have helped me throughout my time here at Iowa State.

Thanks also go to my parents and family, whose love and support I could always count on, and without which I could not have completed this work.

The United States Government has assigned the DOE Report number IS-T 2037 to this thesis. This document has been authored by the Iowa State University of Science and Technology under Contract No. W-7405-ENG-82 with the U. S. Department of Energy. The U. S. Government retains a non-exclusive, paid-up, irrevocable, world-wide license to publish or reproduce the published form of this document, or allow others to do so, for U. S. Government purposes.